



AVR182: Zero Cross Detector

Features

- Interrupt Driven
- Modular C Source Code
- Size Efficient Code
- Accurate and Fast Detection
- A Minimum of External Components

Introduction

One of the many issues with developing modern applications is to keep the spikes and EMI at a minimum, especially when switching AC mains in and out. Most of today's new applications are controlled by one or more microcontrollers and this gives the possibility to prevent this noise in a simple and cost efficient way.

Noise produced during switching is dependant on the amplitude of the AC sinus at the actual switching point. To get this noise as low as possible the ideal switching would be when the amplitude is 0 volt. The amplitude is crossing 0 volt at the sinus "zero crossing". Switching mains in and out at the zero crossing requires a way of detecting when the next crossing will be and launching a switching action at the crossing. This raises the need for a cost efficient way to detect the zero crossing. This application note explains how to do that.

Zero cross detection can also be used for other purposes, such as frequency calculation and relative phase measuring.

Figure 1. Zero Cross Detector Using AVR®

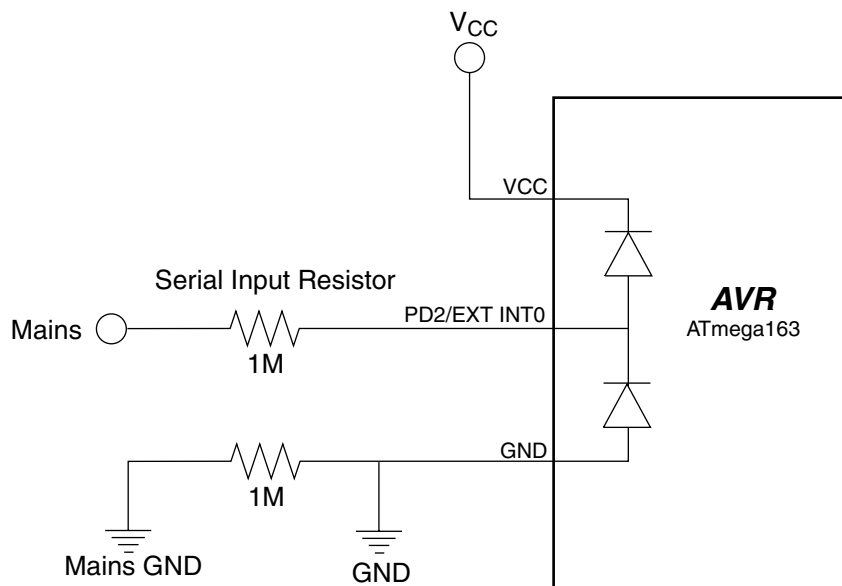

8-bit **AVR**[®]
RISC
Microcontroller

Application
Note

Rev. 2508A-AVR-03/02



Application Example

This application note shows the user how to implement a zero cross detector with a minimum of external components. It should be noted that this solution will not give any galvanic isolation for the microcontroller against the AC mains. The zero cross sense resistor can be a way for electronic noise to get into the system.

This will not be described in this application note. Please see “AVR040: EMC Design Considerations” for further details about this.

The application uses ATmega16, but the code can be recompiled for any AVR device.

Hardware

To protect the device from voltages above V_{CC} and below GND, the AVR has internal clamping diodes on the I/O pins (see Figure 1). The diodes are connected from the pins to V_{CC} and GND and keep all input signals within the AVR’s operating voltage (see Figure 2). Any voltage higher than $V_{CC} + 0.5V$ will be forced down to $V_{CC} + 0.5V$ (0.5V is the voltage drop over the diode) and any voltage below $GND - 0.5V$ will be forced up to $GND - 0.5V$.

By adding a large resistor in series, these diodes can be used to convert a high voltage sinus signal down to a low voltage square wave signal, with amplitude within the AVR’s operating voltage $\pm 0.5V$. The diodes will thus clamp the high voltage signal down to the AVR’s operating voltage.

Note that the series resistor and the pin input capacitance form an RC filter that will introduce a small phase difference between the square wave and the AC mains signal. The phase difference is insignificant in the current example, see “RC Filter and Delay Between $V_{CC}/2$ and the Actual Zero Cross” on page 6 for more details.

As the square wave signal is in phase with the AC mains, using the falling edge will tell very accurately where the zero crossing happens. By using this signal the AVR can be programmed to be a very accurate zero cross detector with a very small and interrupt-driven code.

The square wave is the mains signal with its tops cut off and will have the same voltage from $V_{CC} - 0.5V$ to $V_{CC} + 0.5V$ as the mains signal (see Figure 2). When the square wave triggers the AVR’s falling edge interrupt at around $V_{CC}/2$, the mains amplitude will also be at $V_{CC}/2$ and just before a zero crossing. If this is done on a falling edge the AVR will get an interrupt just before the zero crossing and will have time to start a zero crossing action at the actual crossing point. The interrupt will be triggered at around $V_{CC}/2$, as this is the middle of the AVR’s logical threshold voltage.

The signal is connected to the External Interrupt 0-pin which makes it possible to place the zero cross detection routine in an interrupt routine and make the detection fully interrupt driven. Figure 3 shows a oscilloscope screenshot of the actual input signal. Note that the Mains signal is scaled and the rising edge of the external int 0-pin is the same edge as for the Mains, because of the scaling, the Mains edge looks like it appears after the external int 0 edge.

Figure 2. Square Wave Input Signal on External Interrupt 0-pin

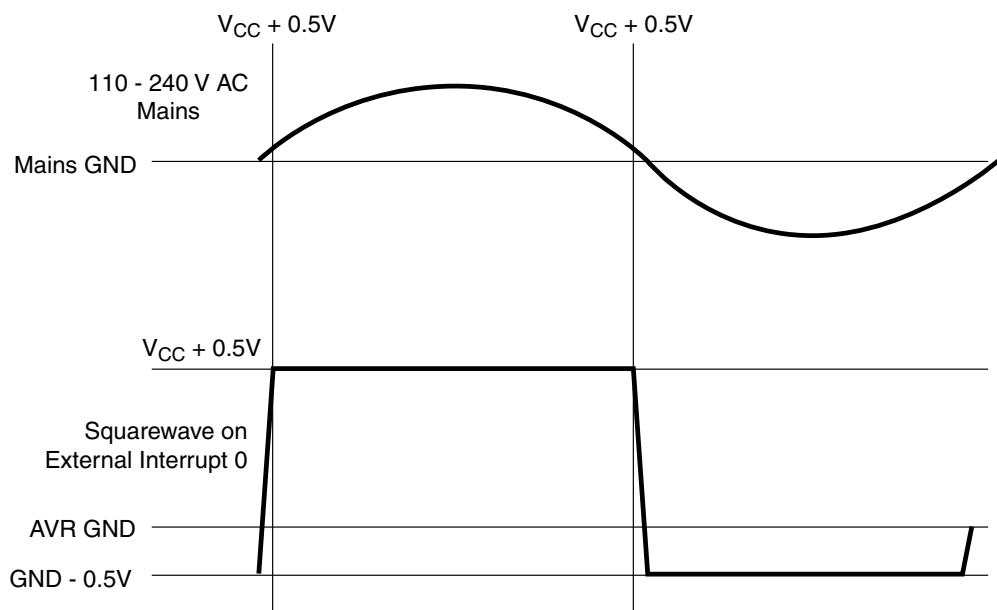
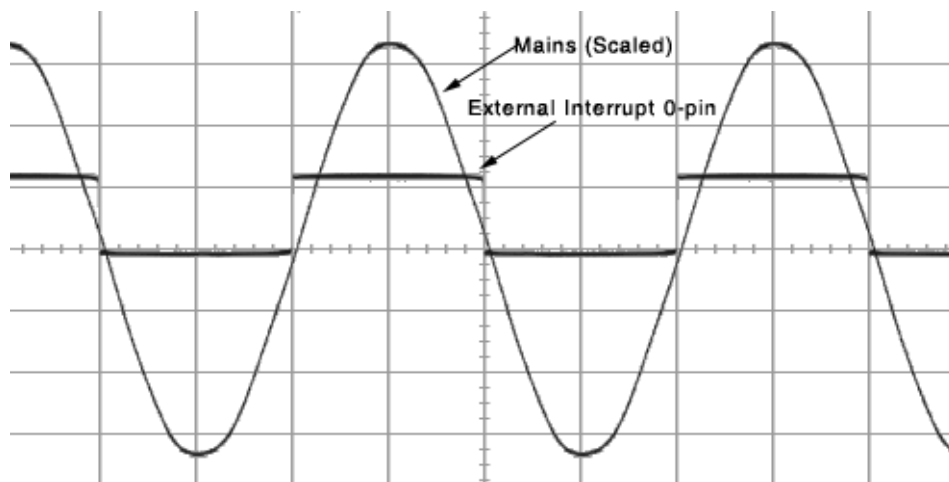

Figure 3. Oscilloscope Screenshot of Square Wave Input on External Interrupt 0-pin



The series input resistor is a 1 MΩ resistor. It is not recommended that the clamping diodes are conducting more than maximum 1 mA and 1 MΩ will then allow a maximum voltage of approximately 1,000V.

Any voltage higher than 1,000V would probably be spikes or surges. The clamping diodes are able to handle spikes for a short period of time but not surges. The application note will not go into how to protect against surges, but simply recommend implementing protection against surges in the design.

Most resistors have an upper maximum voltage limit. Make sure that the resistors used in the application can handle the highest possible AC mains voltage, including high voltage spikes.

For systems with lower mains voltages the resistor value can be changed, but in general it should be able to sense 110 - 240V AC systems without any problems.

The 1 M Ω resistor in series to mains GND will ensure a correct ground potential for the application.

Software

The external hardware and internal clamping diodes will make a square wave signal on the AVR's External Interrupt 0-pin. As described in the hardware section the square wave will have the same frequency as the AC mains. The high period of the signal will be when the AC mains amplitude is above $V_{CC}/2$. This gives mains zero crossings very close to the edges of the square wave. The rising edge of the square wave is slightly after the crossing and the falling edge is slightly before the crossing.

As the falling edge of the square wave is just before a zero crossing, the falling edge interrupt will occur so close to the actual crossing that it immediately can start the zero crossing action.

In this application example the zero crossing action will only be to set PB0 high for a short period of time and then immediately start looking for the next falling edge zero crossing. This makes it very easy to check if the zero crossing detection is correct or not. Simply connect an oscilloscope probe to the mains and another to PB0. If the detection is correct this will show PB0 going high for a short period of time at each negative edge zero crossing (See Figure 4 and Figure 5).

Figure 4. Screenshot from Oscilloscope, Mains Input and PB0 Output

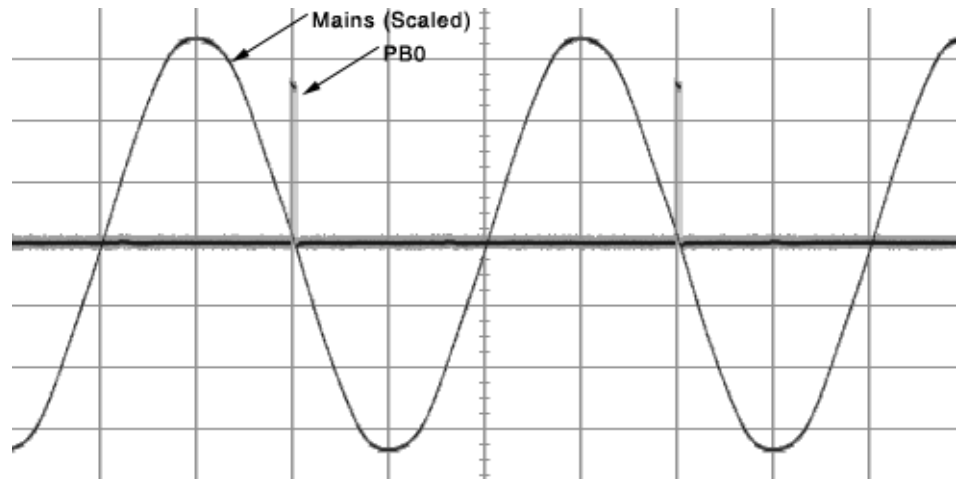
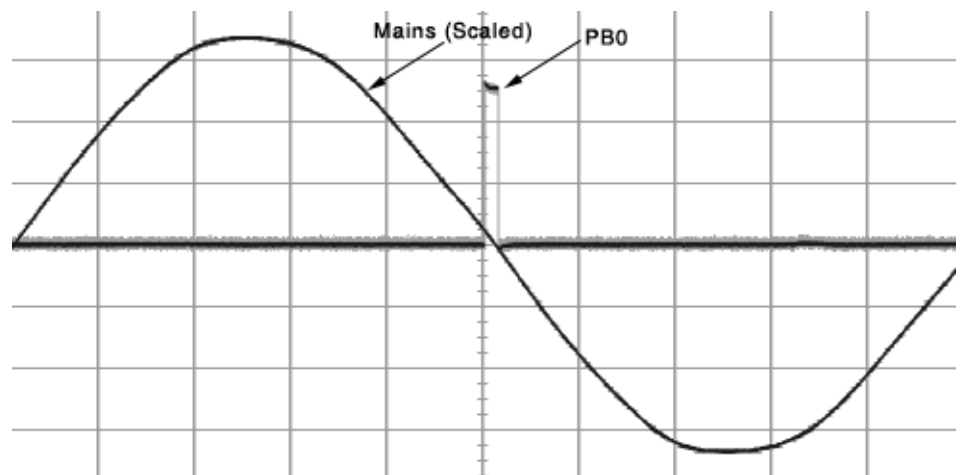

Figure 5. Screenshot from Oscilloscope, Mains Input and PB0 Output



In a real application the disabling of external interrupt 0 before returning from the interrupt routine will make a single detection. To detect a new zero crossing, simply enable the falling edge interrupt again in the main program.

To make sure the interrupts are valid and not only products of spikes on the pin, there is a filter implemented in the interrupt routine. The filter samples the level on the interrupt line five times and compares the values to see if the value is stable. If the value is not the same for all the samples, the event is discarded and the routine returns to the main program waiting for a new interrupt (See Figure 6).

For more details about the software, please see the comments in the code.

Figure 6. Software Flowchart for Main Program and External Interrupt 0 Handling Routine

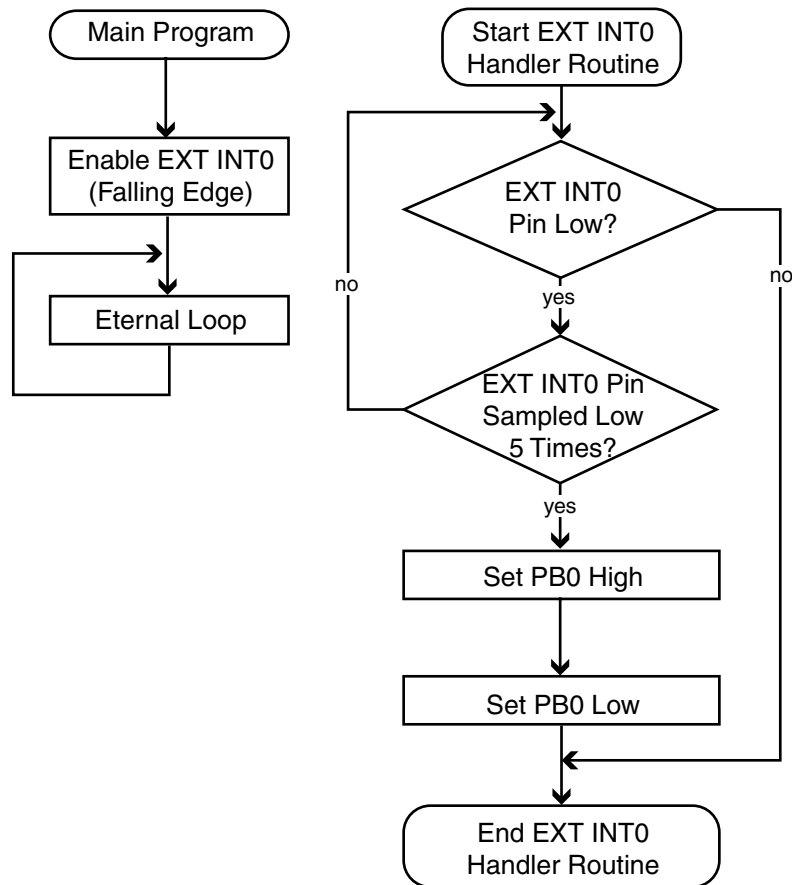

Special Considerations

Applying high voltages to microcontrollers increases the possibility of malfunction or injury. It is advisable to follow a few special steps as any error can cause severe damage to components, emulators or electric shock.

Emulators and Clamp Diodes

The AVR family is set up with a complete system of emulators, but because of the nature of the PODs of some of the emulators, they are not equipped with internal clamping diodes. ICE200 is the only emulator with clamping diodes. ICE10, ICE30, and ICE50 do not contain clamping diodes. By adding external clamping diodes the emulator will get the same input as the part.

To apply a high AC voltage to an emulator can cause severe damage on the equipment and care should be exercised. It is recommended to use isolation transformers on the mains and galvanic separated RS-232 communication to the PC.

RC Filter and Delay Between $V_{CC}/2$ and the Actual Zero Cross

The series resistor and the input pin capacitance will form an RC filter, which will delay the response compared to the actual zero crossing.

The 1 M Ω resistor together with the input capacitance on the AVR introduces a delay that brings the detection very close to the actual crossing. For other AC voltages or series resistors it is recommended to do a test with an oscilloscope to see how close the detection is to the actual crossing. This makes it very easy to check if the zero crossing detection is correct or not. Connect an oscilloscope probe to the mains and another to PB0. A correct detection will show PB0 going high for a short period of time at each falling edge zero crossing (see Figure 4 and Figure 5).

If the detection is after the actual crossing, the next crossing should be targeted by adding a delay to the action. The delay should be equal to the time left before the next crossing

The series resistor can also be modified somewhat to make the detection closer but note that the maximum current through the AVR's clamping diode should not be higher than 1 mA.

Ground must Be Symmetrical

The mains ground must be symmetrical to the phases in the mains net. As the sensor is only using one phase and ground, this is necessary to detect the actual zero crossing according to the three phases in the mains net. If ground is not symmetrical it is not possible to know when the crossing is using only one phase. This can only be a problem in delta shaped mains net. Most countries, except Norway and Albania, use star shaped mains system and will not have this problem.

How to Calculate a Slow Switch (Relay)

The typical use of a zero cross detector can be to control a mains relay. As relays have a response time that will be larger than the delay from the zero cross sensing to the actual crossing one technique can be to add a delay to the handling, i.e., sense the crossing on falling edge and make the relay close on rising edge.

To do this, the response time of the relay and the frequency of the mains has to be known. These values can either be known from the manufacturer, measured in a lab or by the AVR itself.

The measurement can be implemented into the AVR software. By using the zero cross detector it can easily sample the frequency of the signal and with few external components it can also measure the relay response time. This will give a universal system that can adapt to almost any AC mains frequency and relay response time. It will also continue being correct even if the relay response time or frequency will change over time.



Atmel Headquarters

Corporate Headquarters
2325 Orchard Parkway
San Jose, CA 95131
TEL 1(408) 441-0311
FAX 1(408) 487-2600

Europe

Atmel SarL
Route des Arsenaux 41
Casa Postale 80
CH-1705 Fribourg
Switzerland
TEL (41) 26-426-5555
FAX (41) 26-426-5500

Asia

Atmel Asia, Ltd.
Room 1219
Chinachem Golden Plaza
77 Mody Road Tsimhatsui
East Kowloon
Hong Kong
TEL (852) 2721-9778
FAX (852) 2722-1369

Japan

Atmel Japan K.K.
9F, Tonetsu Shinkawa Bldg.
1-24-8 Shinkawa
Chuo-ku, Tokyo 104-0033
Japan
TEL (81) 3-3523-3551
FAX (81) 3-3523-7581

Atmel Operations

Memory

Atmel Corporate
2325 Orchard Parkway
San Jose, CA 95131
TEL 1(408) 436-4270
FAX 1(408) 436-4314

Microcontrollers

Atmel Corporate
2325 Orchard Parkway
San Jose, CA 95131
TEL 1(408) 436-4270
FAX 1(408) 436-4314

Atmel Nantes

La Chantrerie
BP 70602
44306 Nantes Cedex 3, France
TEL (33) 2-40-18-18-18
FAX (33) 2-40-18-19-60

ASIC/ASSP/Smart Cards

Atmel Rousset
Zone Industrielle
13106 Rousset Cedex, France
TEL (33) 4-42-53-60-00
FAX (33) 4-42-53-60-01

Atmel Colorado Springs
1150 East Cheyenne Mtn. Blvd.
Colorado Springs, CO 80906
TEL 1(719) 576-3300
FAX 1(719) 540-1759

Atmel Smart Card ICs
Scottish Enterprise Technology Park
Maxwell Building
East Kilbride G75 0QR, Scotland
TEL (44) 1355-803-000
FAX (44) 1355-242-743

RF/Automotive

Atmel Heilbronn
Theresienstrasse 2
Postfach 3535
74025 Heilbronn, Germany
TEL (49) 71-31-67-0
FAX (49) 71-31-67-2340

Atmel Colorado Springs
1150 East Cheyenne Mtn. Blvd.
Colorado Springs, CO 80906
TEL 1(719) 576-3300
FAX 1(719) 540-1759

Biometrics/Imaging/Hi-Rel MPU/ High Speed Converters/RF Datacom

Atmel Grenoble
Avenue de Rochepleine
BP 123
38521 Saint-Egreve Cedex, France
TEL (33) 4-76-58-30-00
FAX (33) 4-76-58-34-80

e-mail

literature@atmel.com

Web Site

<http://www.atmel.com>

© Atmel Corporation 2002.

Atmel Corporation makes no warranty for the use of its products, other than those expressly contained in the Company's standard warranty which is detailed in Atmel's Terms and Conditions located on the Company's web site. The Company assumes no responsibility for any errors which may appear in this document, reserves the right to change devices or specifications detailed herein at any time without notice, and does not make any commitment to update the information contained herein. No licenses to patents or other intellectual property of Atmel are granted by the Company in connection with the sale of Atmel products, expressly or by implication. Atmel's products are not authorized for use as critical components in life support devices or systems.

ATMEL® and AVR® are the registered trademarks of Atmel.

Other terms and product names may be the trademarks of others.



Printed on recycled paper.