

M5219L, P, FP

DUAL LOW-NOISE OPERATIONAL AMPLIFIERS(DUAL POWER SUPPLY TYPE)

DESCRIPTION

The M5219 is a semiconductor integrated circuit designed for a preamplifier in audio equipment of stereo and cassette tape decks.

Two low-noise operational amplifier circuits displaying internal phase-compensated high gain and low distortion are contained in a 8-pin SIP, DIP or FP, suitable for application as an equalizer and tone control amplifier of stereo equipment and cassette tape decks.

The unit can also be used as a general-purpose amplifier in portable equipment such as a stereo cassette tape recorder of a single power supply type as it operates at a low supply voltage.

FEATURES

- Low noise $V_{NI}=0.9\mu\text{Vrms typ.}(R_G=2.2k\Omega, \text{RIAA})$
 $S/N=77\text{dB typ. (Shorted input, IHF-A network)}$
 $(\text{RIAA, PHONO}=2.5\text{mVrms})$
- High voltage $V_{CC}=\pm 25\text{V}(50\text{V})$
- Low PHONO maximum input voltage $V_I=230\text{mVrms(typ.)}$
 $(V_{CC}=\pm 22.5\text{V}, f=1\text{kHz})$
- High gain, low distortion $G_{VO}=110\text{dB, THD}=0.001\%(\text{typ.})$
- High slew rate $SR=6.5\text{V}/\mu\text{s}(\text{typ.})$
- High load current, high power dissipation $I_{LP}=\pm 50\text{mA}, P_d=800\text{mW(SIP)}$
 $P_d=625\text{mW(DIP)}, P_d=440\text{mW(FP)}$

APPLICATION

General-purpose preamplifier in stereo equipment, tape decks and radio stereo cassette recorders.

RECOMMENDED OPERATING CONDITIONS

- Supply voltage range $\pm 2 \sim \pm 22.5\text{V}$
- Rated supply voltage $\pm 22.5\text{V}$

PIN CONFIGURATION (TOP VIEW)

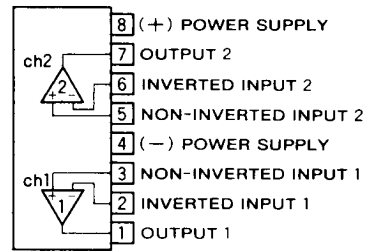

Outline 8P5 (M5219L)

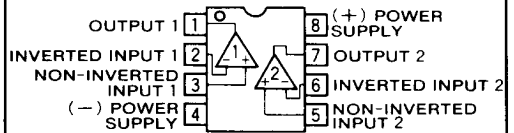

Outline 8P4 (M5219P)
Outline 8P2S (M5219FP)

EQUIVALENT CIRCUIT

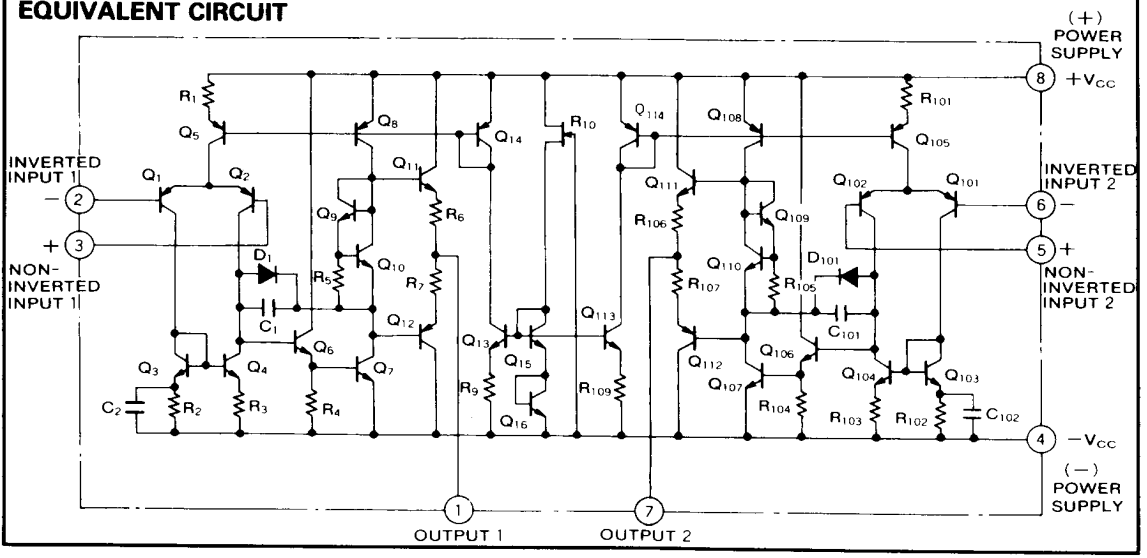

DUAL LOW-NOISE OPERATIONAL AMPLIFIERS(DUAL POWER SUPPLY TYPE)

ABSOLUTE MAXIMUM RATINGS ($T_a=25^{\circ}\text{C}$, unless otherwise noted)

Symbol	Parameter	Conditions	Ratings	Unit
V_{CC}	Supply voltage		$\pm 25(50)$	V
I_{LP}	Load current		± 50	mA
V_{id}	Differential input voltage		± 30	V
V_{ic}	Common input voltage		$\pm 22.5\text{V}$	V
P_d	Power dissipation		800(SIP)/625(DIP)/440(FP)	mW
K_{θ}	Thermal derating	$T_a \geq 25^{\circ}\text{C}$	8(SIP)/6.25(DIP)/4.4(FP)	mW/ $^{\circ}\text{C}$
T_{opr}	Ambient temperature		$-20 \sim +75$	$^{\circ}\text{C}$
T_{stg}	Storage temperature		$-55 \sim +125$	$^{\circ}\text{C}$

ELECTRICAL CHARACTERISTICS ($T_a=25^{\circ}\text{C}$, $V_{CC}=\pm 22.5\text{V}$)

Symbol	Parameter	Test conditions	Limits			Unit
			Min	Typ	Max	
I_{CC}	Circuit current	$V_{in}=0$		3.5	7.0	mA
V_{IO}	Input offset voltage	$R_S \leq 10\text{k}\Omega$		0.5	6.0	mV
I_{IB}	Input bias current			0.3		μA
G_{VO}	Open loop voltage gain	$f=100\text{Hz}$, $R_L=47\text{k}\Omega$, $C_{NF}=470\mu\text{F}$	90	110		dB
V_{OM}	Maximum output voltage	$f=1\text{kHz}$, $\text{THD}=0.1\%$, $R_L=47\text{k}\Omega$, RIAA	12.5	14.0		Vrms
THD	Total harmonic distortion	$f=1\text{kHz}$, $V_O=5\text{Vrms}$, $R_L=47\text{k}\Omega$, RIAA		0.001	0.03	%
V_{NI}	Input referred noise voltage	$R_g=2.2\text{k}\Omega$, $\text{BW}=10\text{Hz} \sim 30\text{kHz}$, RIAA		0.9	1.8	μVrms
S/N	Signal-to-noise ratio	Shorted input ($R_g=47\Omega$), IHF-A network PHONO=2.5mVrms, RIAA		77		dB

TEST CIRCUITS

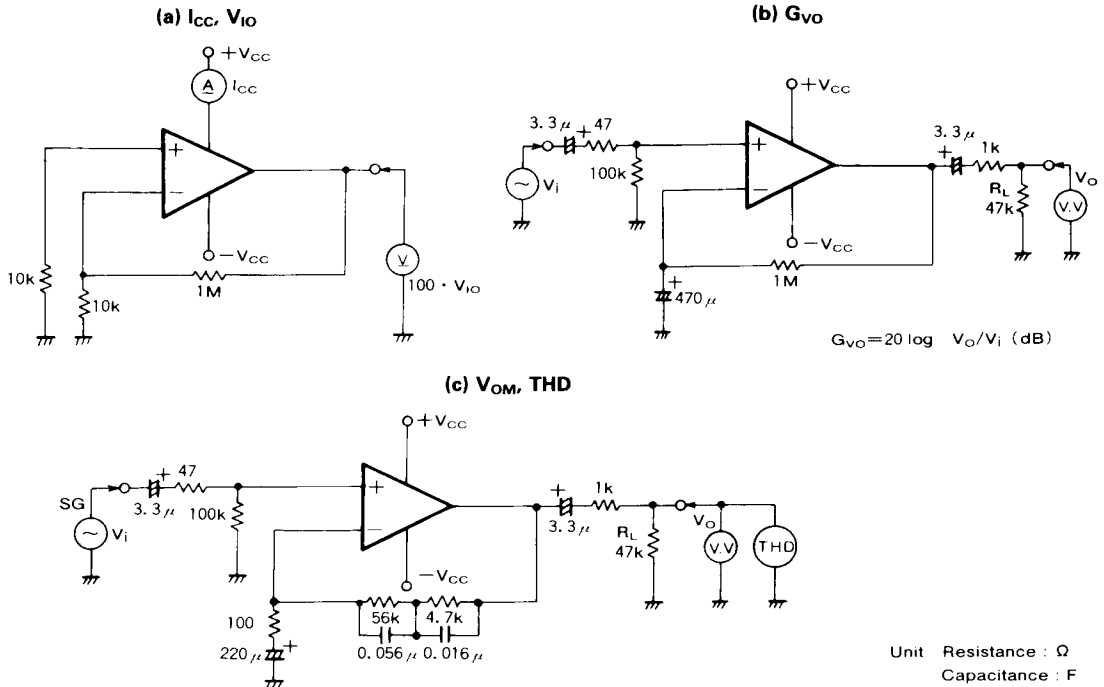

DUAL LOW-NOISE OPERATIONAL AMPLIFIERS(DUAL POWER SUPPLY TYPE)

TEST CIRCUIT

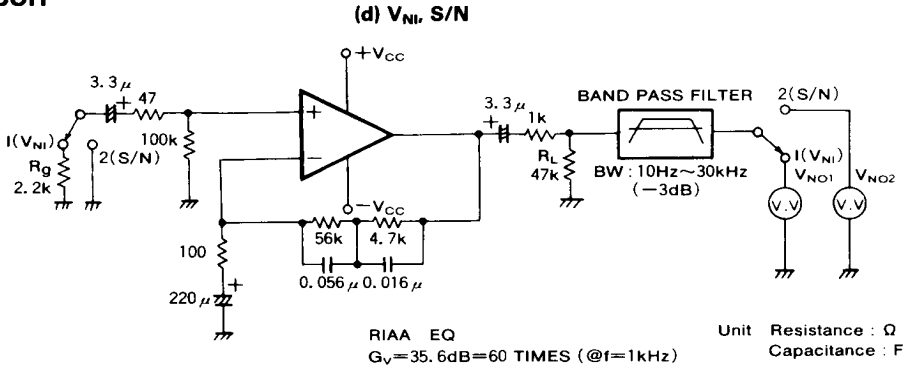

- $V_{Ni}=V_{NO1}/60(\mu\text{Vrms})$
- $S/N=20\log(2.5\text{mVrms}/(V_{NO2}/60))\text{ (dB)}$

An AC voltmeter V.V with a built-in IHF-A network filter should be used for measuring the S/N ratio.

TYPICAL CHARACTERISTICS

**THERMAL DERATING
 (MAXIMUM RATING)**

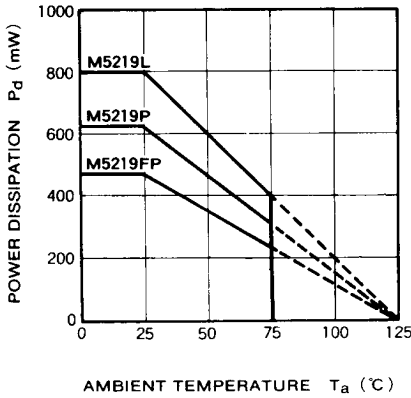

**VOLTAGE GAIN VS.
 FREQUENCY RESPONSE**

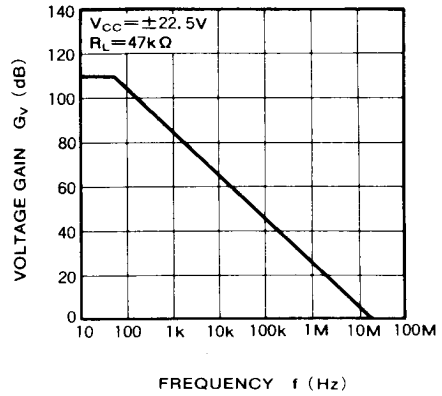

**CIRCUIT CURRENT VS.
 SUPPLY VOLTAGE**

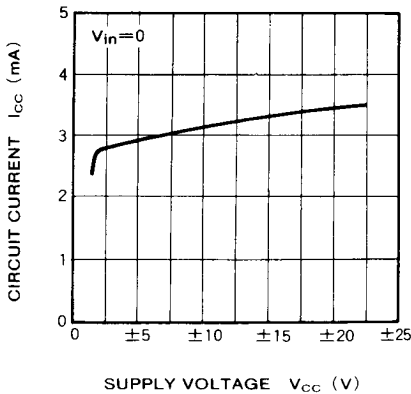

**CIRCUIT CURRENT VS.
 AMBIENT TEMPERATURE**

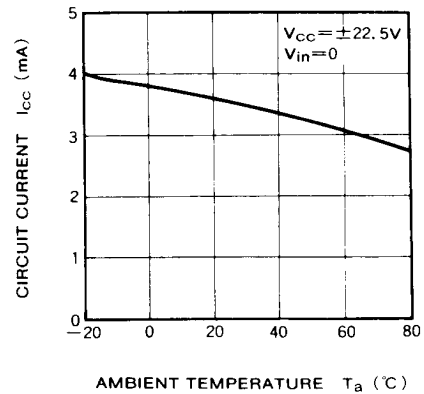

DUAL LOW-NOISE OPERATIONAL AMPLIFIERS(DUAL POWER SUPPLY TYPE)

APPLICATION EXAMPLES

(1) Stereo equalizer amplifier circuit

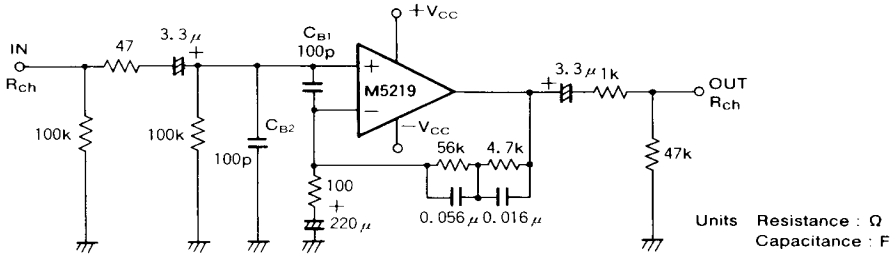

TYPICAL CHARACTERISTICS ($V_{CC} = \pm 22.5V$, RIAA)

- $G_v = 35.6dB$ ($f = 1kHz$)
- $V_{Ni} = 0.9 \mu V_{rms}$ ($R_g = 2.2k\Omega$, $BW = 10Hz \sim 30kHz$)
- $S/N = 77dB$ (IHF-A network, shorted input, $2.5mV_{rms}$ input sensitivity)
- $THD = 0.001\%$ ($f = 1kHz$, $V_o = 5V_{rms}$)

L_{ch} circuit constants are identical to those of R_{ch}

C_{B1} , C_{B2} : Capacitors for buzz prevention, use if required.

R_o : Resistor used to prevent parasitic oscillation for capacitive loads and current limiting with shorted and other abnormal load conditions.

Units Resistance : Ω
 Capacitance : F

TOTAL HARMONIC DISTORTION VS. OUTPUT VOLTAGE

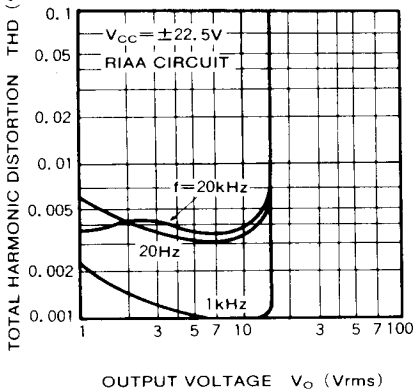

INPUT-REFERRED NOISE VOLTAGE VS. SIGNAL SOURCE RESISTANCE

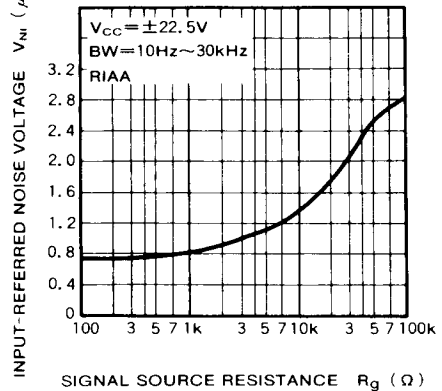

SIGNAL-TO-NOISE RATIO VS. SIGNAL SOURCE RESISTANCE

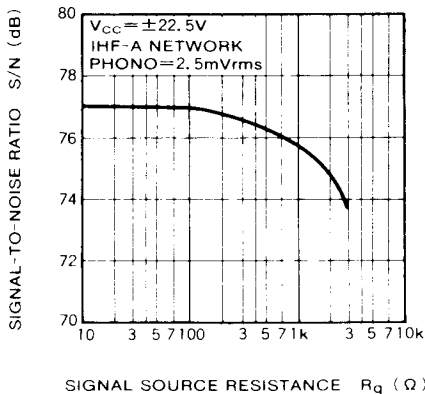

OUTPUT VOLTAGE VS. LOAD RESISTANCE

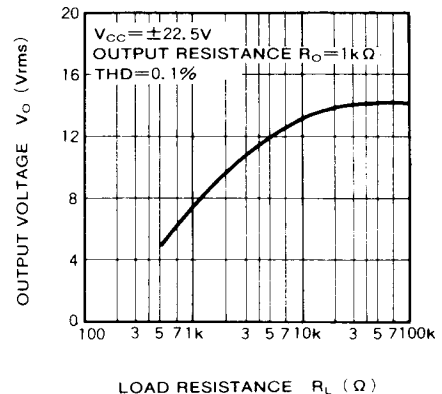

DUAL LOW-NOISE OPERATIONAL AMPLIFIERS(DUAL POWER SUPPLY TYPE)

OUTPUT VOLTAGE VS. SUPPLY VOLTAGE

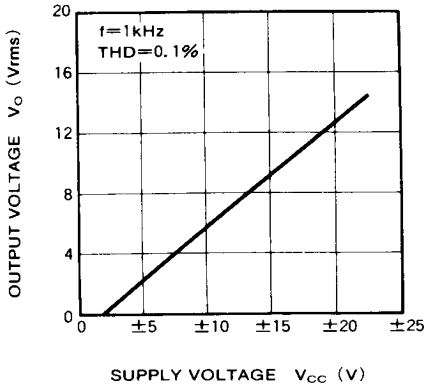

HUM REJECTION VS. FREQUENCY

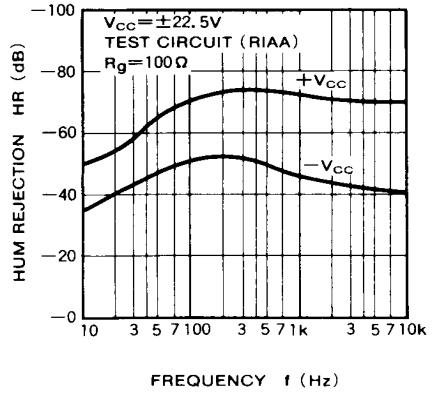

(2) High S/N stereo DC ICL equalizer circuit

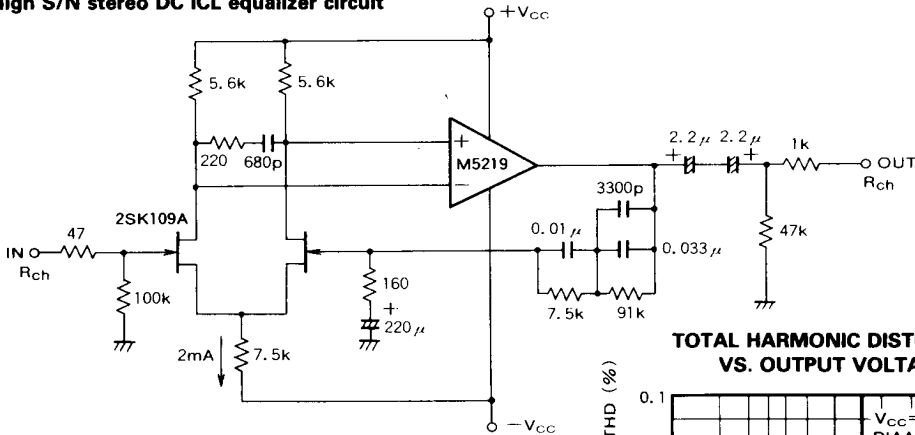

L_{ch} circuit constants are identical to those of R_{ch} .

Units Resistance : Ω
 Capacitance : F

TYPICAL CHARACTERISTICS ($V_{CC} = \pm 22.5V$, RIAA)

- S/N=85dB(IHF-A network, shorted input, 2.5mVrms input sensitivity)
- $V_{NI} = 0.77 \mu Vrms$ ($R_g = 5.1k\Omega$, BW=5Hz~100kHz)
- $G_v = 35.6dB$ ($f = 1kHz$)

TOTAL HARMONIC DISTORTION VS. OUTPUT VOLTAGE

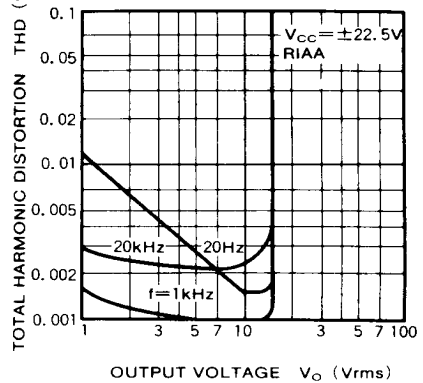

DUAL LOW-NOISE OPERATIONAL AMPLIFIERS(DUAL POWER SUPPLY TYPE)

(3) Tape deck equalizer amplifier circuit

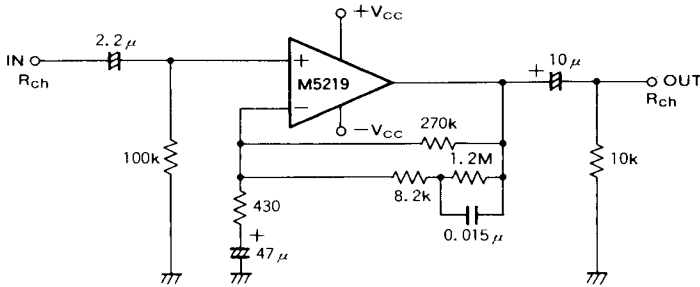

Units Resistance : Ω
 Capacitance : F

R_{ch} circuit constants are identical to those of R_{ch} .

TYPICAL CHARACTERISTICS ($V_{CC} = \pm 15V$, NAB)

- $G_V = 29.9 \text{ dB}$ ($f = 1 \text{ kHz}$)
- $V_{NI} = 1.4 \mu \text{ Vrms}$ ($R_g = 2.2 \Omega$, $BW = 20 \text{ Hz} \sim 15 \text{ kHz}$)
- (-117 dBv)

TOTAL HARMONIC DISTORTION VS. OUTPUT VOLTAGE

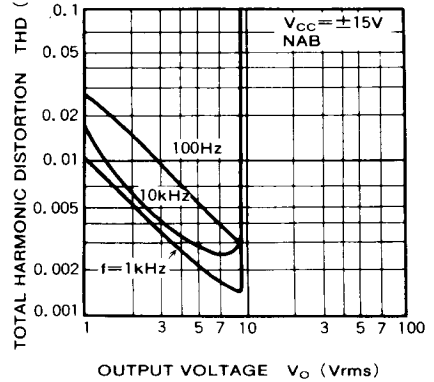

(4) Typical single power supply application

PHONO EQUALIZER AMPLIFIER (RIAA)

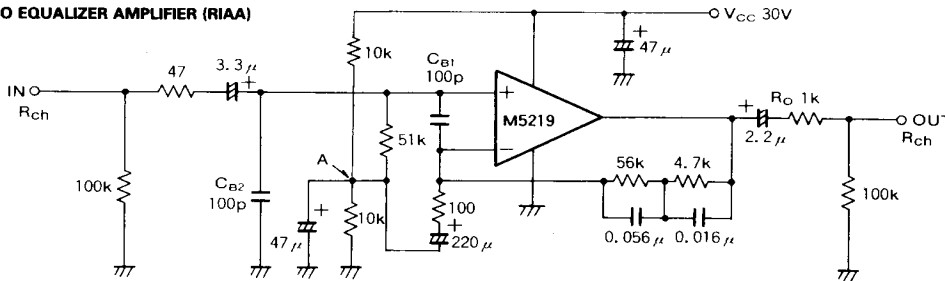

Units Resistance : Ω
 Capacitance : F

TYPICAL CHARACTERISTICS ($V_{CC} = +30V$, RIAA)

- $G_V = 35.6 \text{ dB}$ ($f = 1 \text{ kHz}$)
- $V_{NI} = 0.9 \mu \text{ Vrms}$ ($R_g = 2.2 \Omega$, $BW = 10 \text{ Hz} \sim 30 \text{ kHz}$)
- $S/N = 77 \text{ dB}$ (IHF-A network, shorted input, 2.5 mVrms input sensitivity)

- \rightarrow Point A is the $V_{CC}/2$ point in DC terms (virtual ground) when the device is used as a single power supply type.
- C_{B1} , C_{B2} : Capacitor for buzz prevention, use if required.
- R_O : Resistor used to prevent parasitic oscillation for capacitive loads and current limiting with shorted and other abnormal conditions.

TOTAL HARMONIC DISTORTION VS. OUTPUT VOLTAGE

