

# Lean G\_AMD Beema DIS/UMA (14"/15.6")

# Ultra/Slim

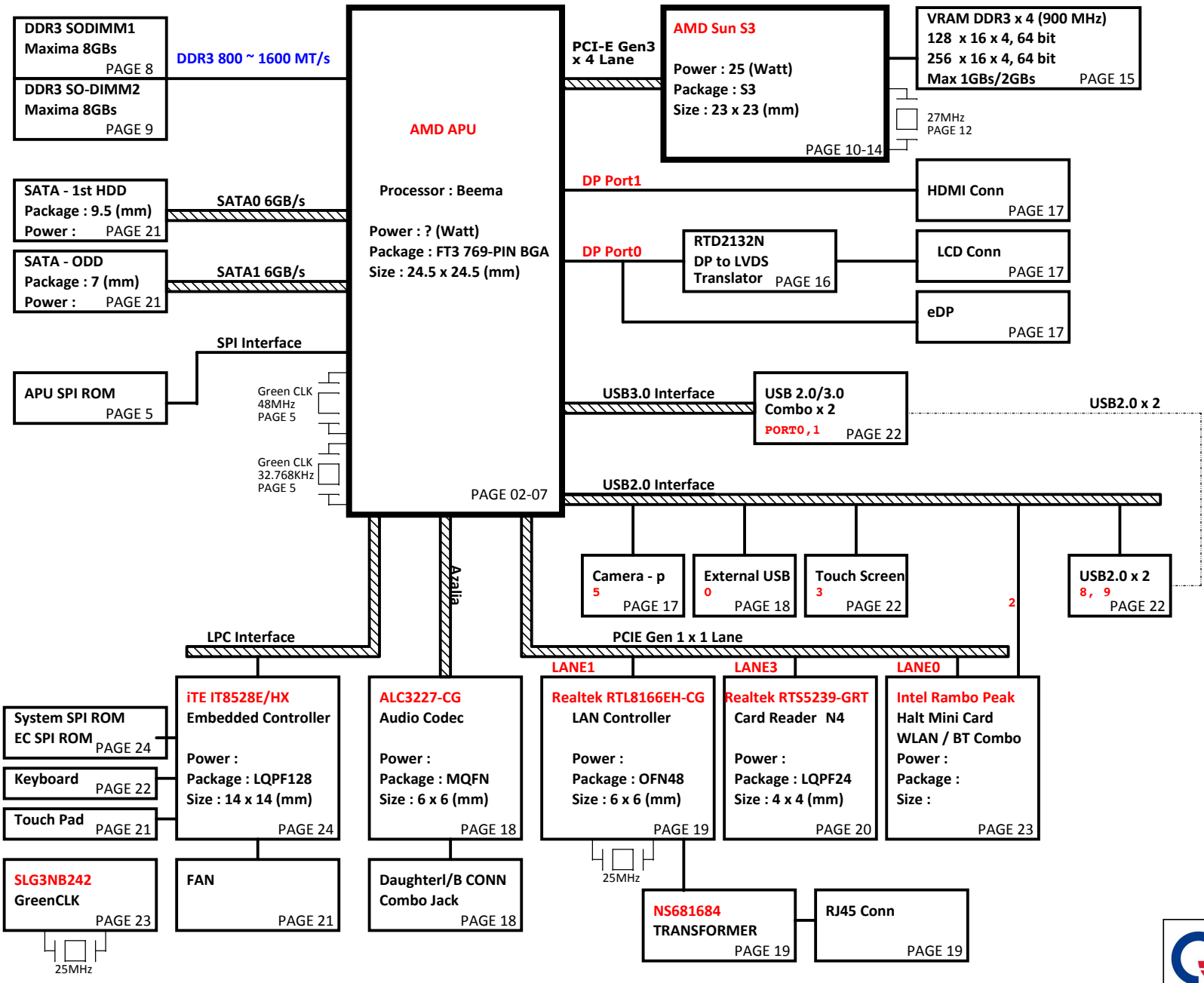

**AMD Sun S3**  
Power : 25 (Watt)  
Package : S3  
Size : 23 x 23 (mm)  
PAGE 10-14

**VRAM DDR3 x 4 (900 MHz)**  
128 x 16 x 4, 64 bit  
256 x 16 x 4, 64 bit  
Max 1GBs/2GBs PAGE 15

27MHz PAGE 12

**PCB 6L STACK UP**

LAYER 1 : TOP  
LAYER 2 : SGND  
LAYER 3 : IN1(High)  
LAYER 4 : IN2(Low)  
LAYER 5 : SVCC  
LAYER 6 : BOT

**Power Source**

**TI BQ24728**  
System Charge Power (+BATChg)  
PAGE 25

**RicteK RT8223PZ**  
System Power (+3VPCU/+5VPCU/  
+3VSS/+5VSS)  
PAGE 26

**AOZ1237QI/APW8824CTI/G9183**  
KABINI Power (+0.95V/+0.95VSS  
/+1.5VSS)  
PAGE 27

**TI TPS51216**  
System Memory Power (+1.5VSSUS/  
+0.75V\_DDR\_VTT)  
Richtek RT8068A  
KABINI Power (+1.8VSS)  
PAGE 28

**Intersil ISL6277HRTZ/ISL6208BCRZ**  
Processor Power (+VCC\_CORE/  
+VDDNB\_CORE)  
PAGE 29~30

**GMT G5934RZ1U**  
System Discharge Power  
(+1.5V/+3V/+5V)  
(+3VSSUS/+3VLANVCC/+1.8V)  
PAGE 31

**On-semi ADP3211A**  
VGA Power (+VGA\_CORE)  
PAGE 32

**Richtek RT8086A**  
DGPU Power (+1.0V\_VGA/+3V\_VGA  
/+1.5V\_VGA/+1.8V\_VGA/)  
PAGE 33

**PROJECT :U99**  
Quanta Computer Inc.

Size A3 Document Number Block Diagram(for HP) Rev 1A  
Date: Monday, May 19, 2014 Sheet 1 of 33

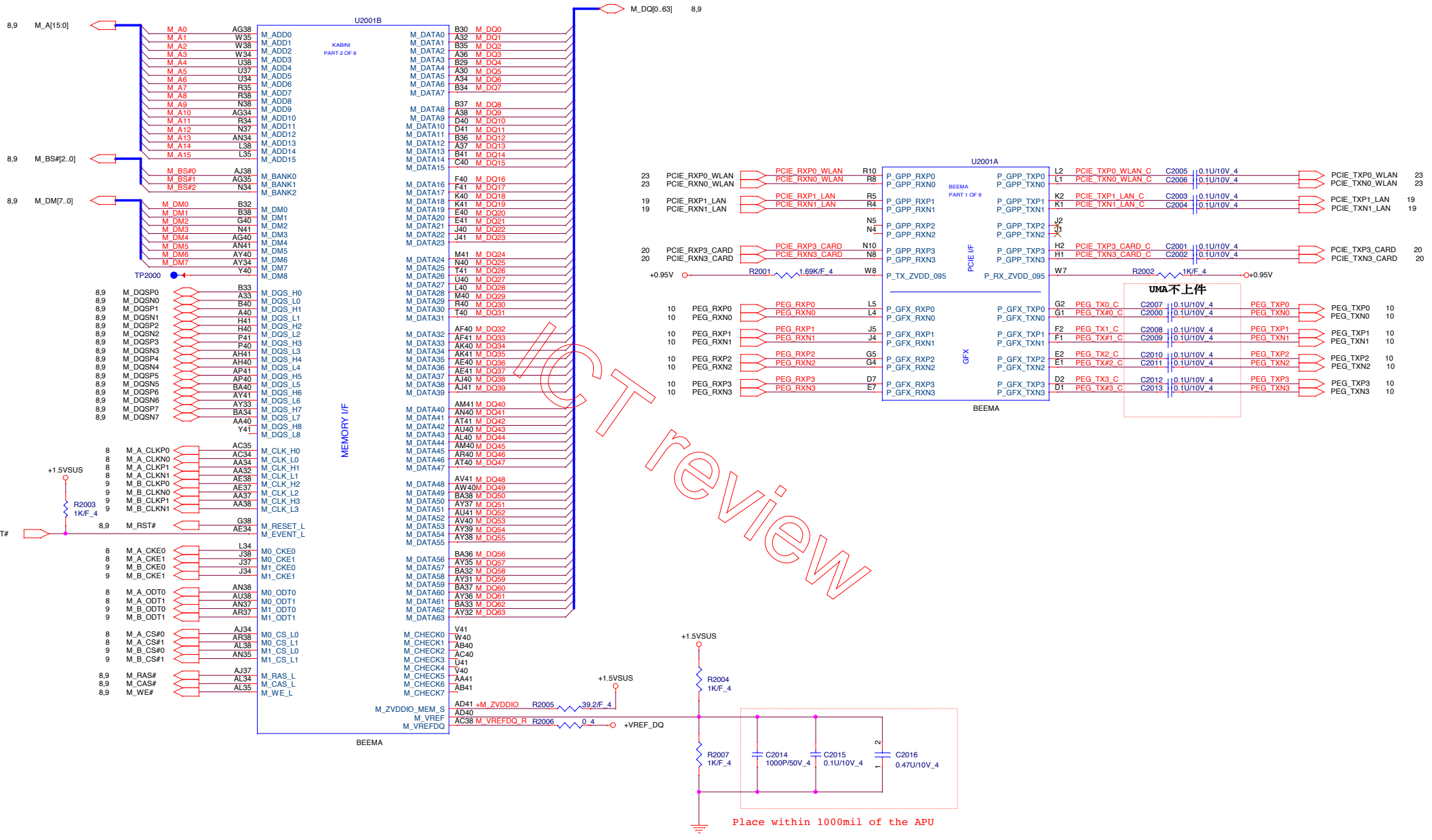

IC T review

6,8,9,28,31,33	+1.5VSUS	
8,9	+VREF_DQ	
5,6,27	+0.95V	

<b>PROJECT :U99</b> Quanta Computer Inc.		
Size	Document Number <b>MEM/PCIE (1/6)</b>	Rev 1A
Date: Monday, May 19, 2014	Sheet 2 of 33	

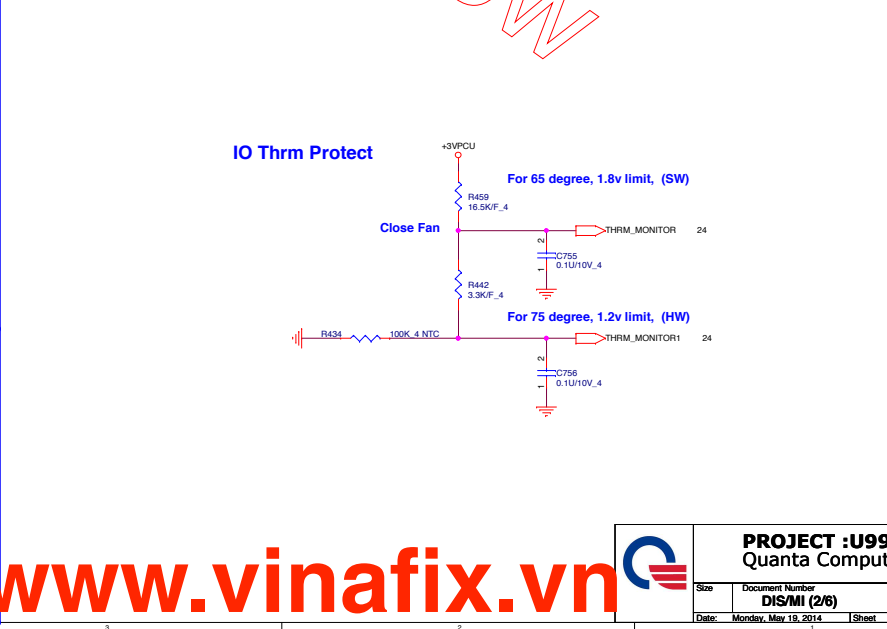
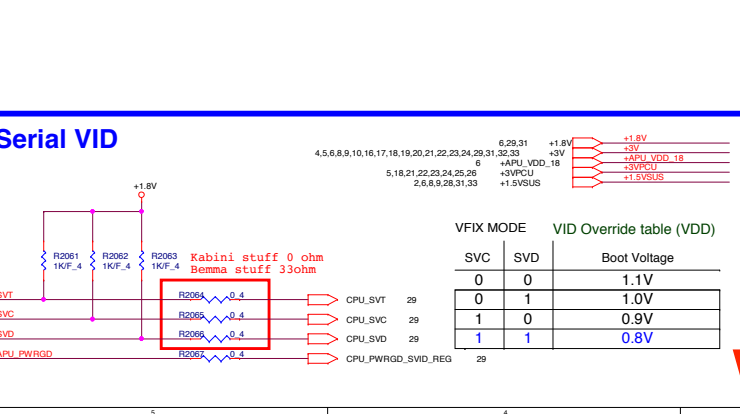
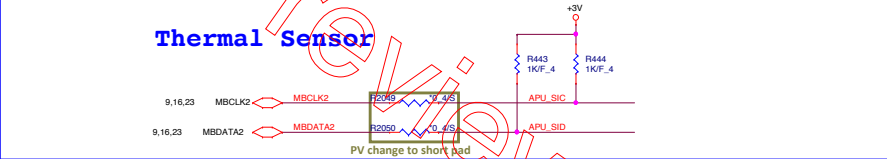
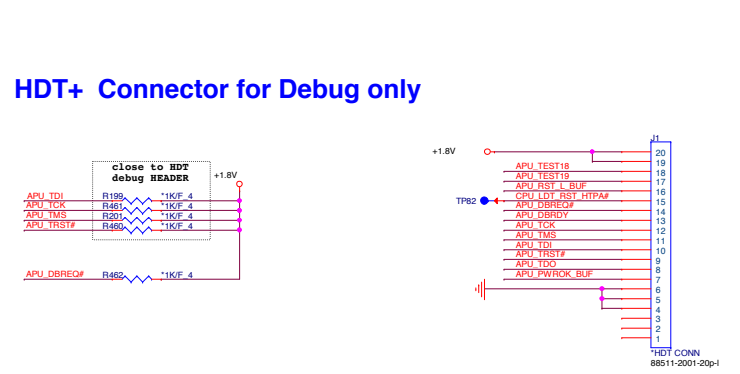
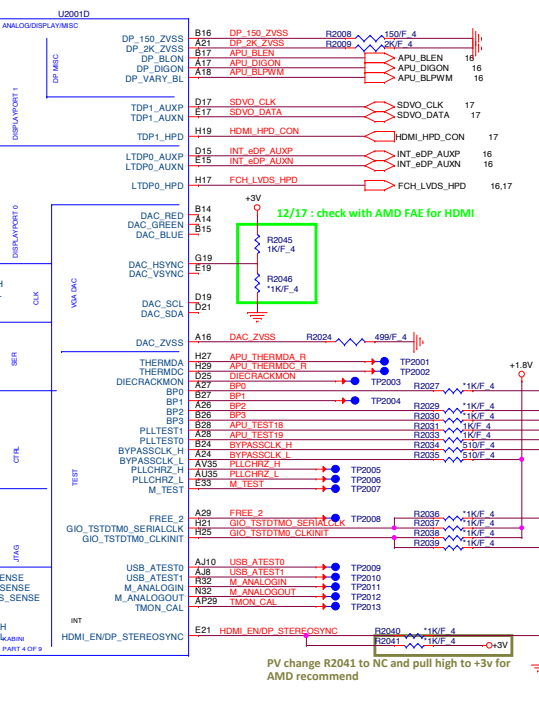
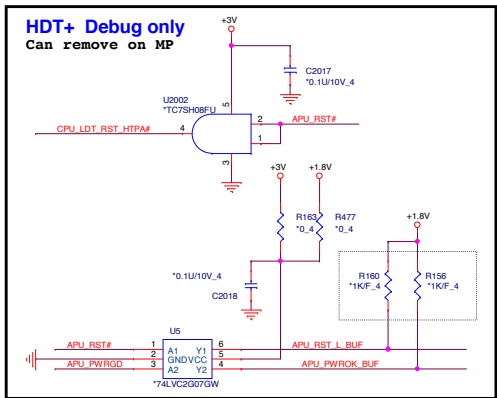
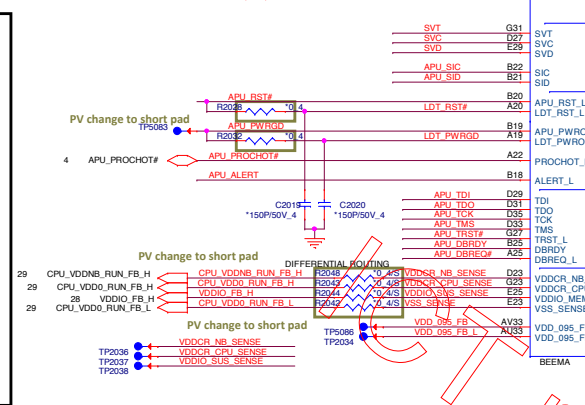
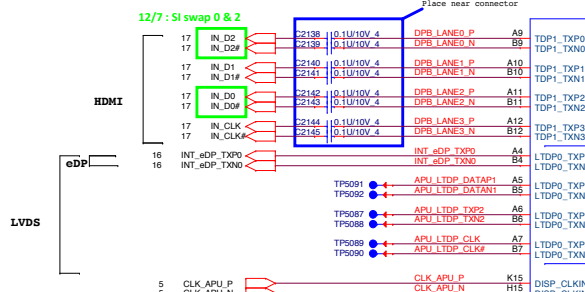
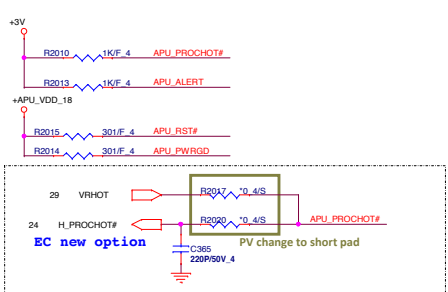

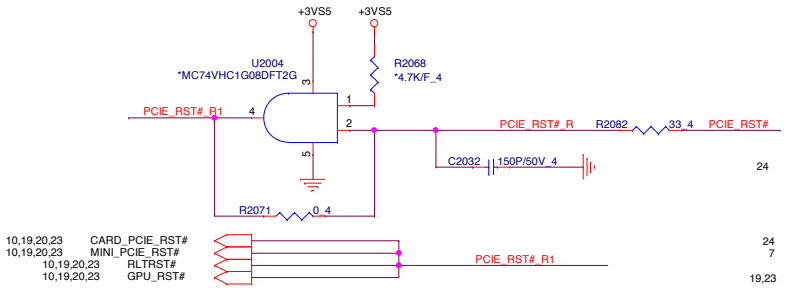

- 10,19,20,23 CARD\_PCIE\_RST#
- 10,19,20,23 MINI\_PCIE\_RST#
- 10,19,20,23 RLTTRST#
- 10,19,20,23 GPU\_RST#

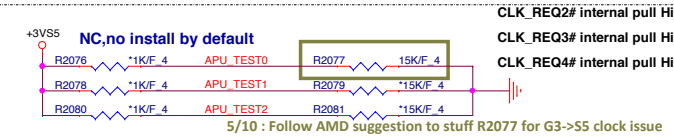

TEST2	TEST1	TEST0	Description
0	0	0	FCH TAP accessible from APU when TAPEN is asserted FCH JTAG pins are overloaded for multiple functions, in this configuration the FCH JTAG are used as non-JTAG pins
0	0	1	Reserved
0	1	X	Reserved
1	TMS	0	FCH JTAG multi-function pins are configured as JTAG pins, in this configuration the FCH TAP can be accessed from FCH JTAG pins
1	TMS	1	Use on ATE only Yuba JTAG enabled

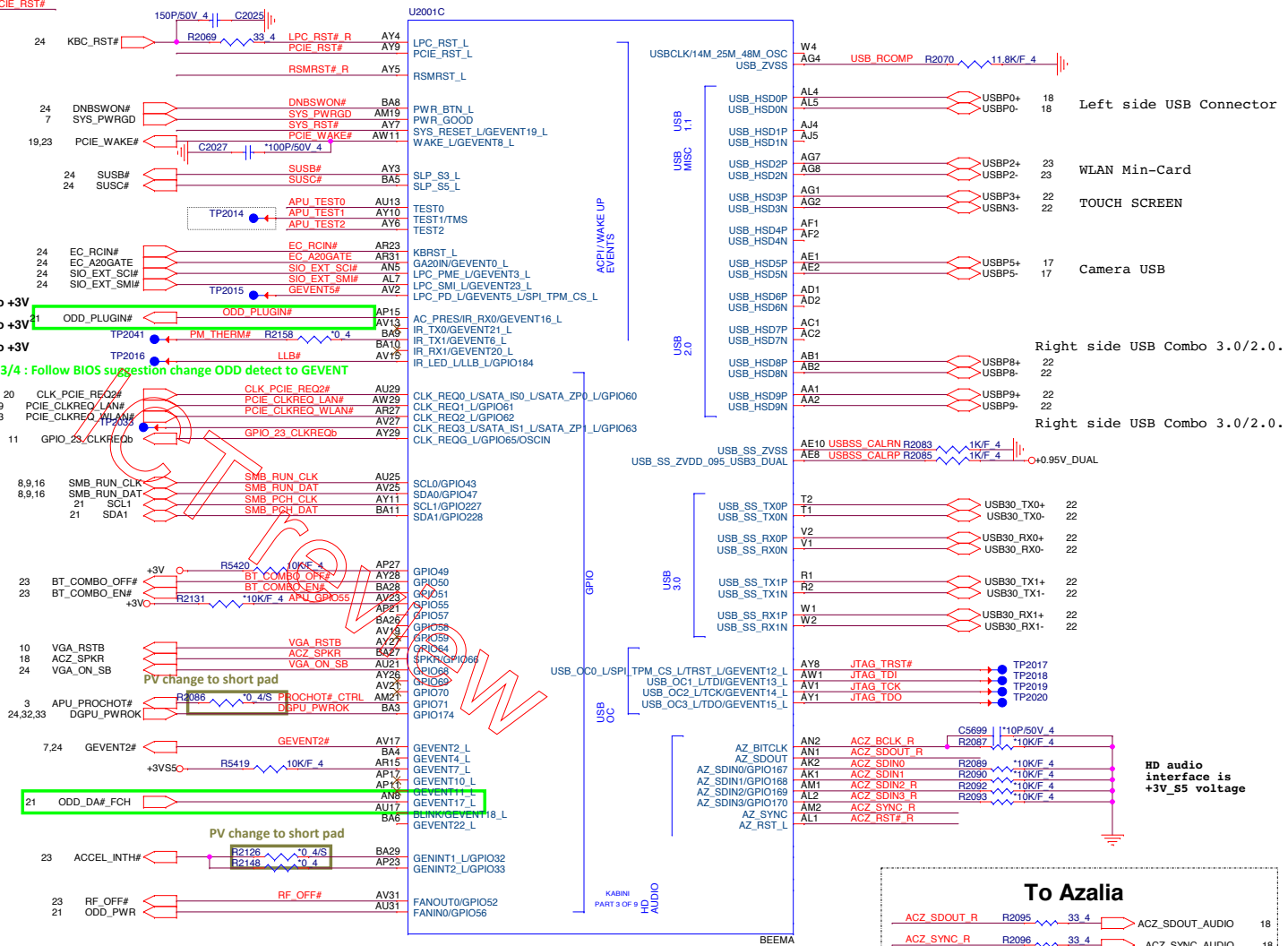
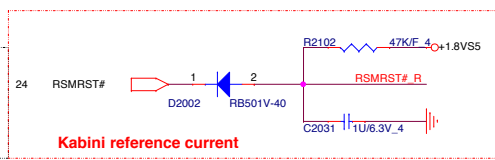
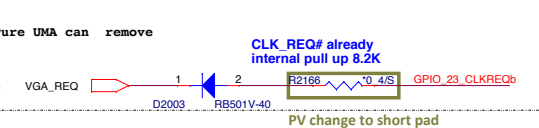
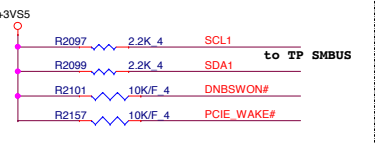
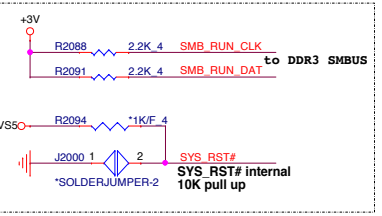

**PROJECT :U99**  
 Quanta Computer Inc.

Size: Document Number: **GPIO/USB/AZ (3/6)** Rev: 1A

Date: Monday, May 19, 2014 Sheet: 4 of 33

SATA HDD

SATA ODD

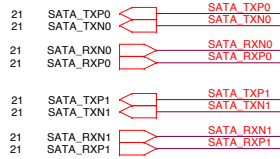

Use with external clock generator only  
 TP2039 ← AY12  
 TP2040 ← BA12

Integrated Clock Mode:  
 Leave unconnected.

UMA不上件

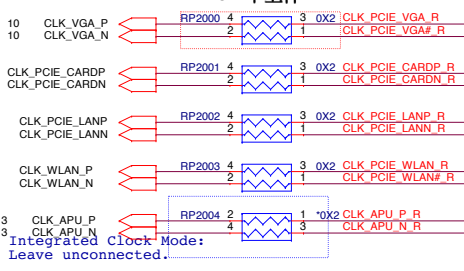

Integrated Clock Mode:  
 Leave unconnected.

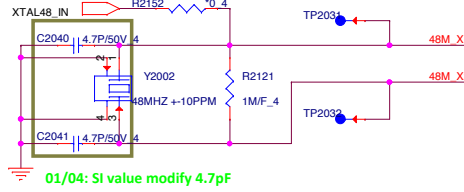

01/04: SI value modify 4.7pF

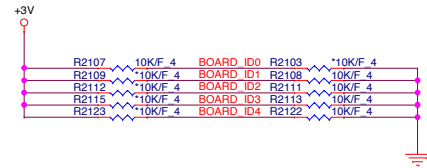
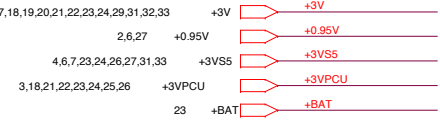
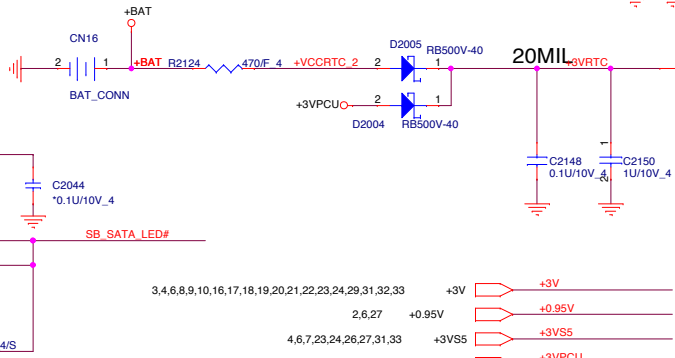

BOARD ID SETTING

Model	BOARD_ID0	BOARD_ID1	BOARD_ID2	BOARD_ID3	BOARD_ID4
14" UMA	0	0	0	0	0
15" UMA	0	1	0	0	0
14" DIS	1	0	0	0	0
15" DIS	1	1	0	0	0

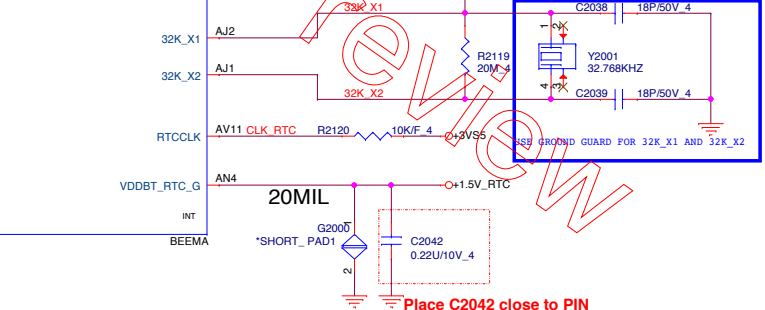
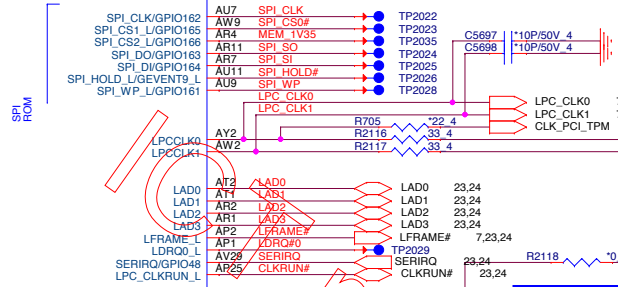
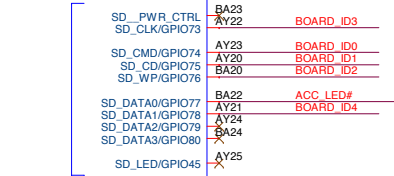

20MIL

Place C2042 close to PIN

APU SPI ROM

Replace to MX25L6436E

Vender	Size	P/N
AMIC	2M	AKE38ZN0801
WINBOND	2M	AKE38FP0N01
Socket		DFHS08FS023

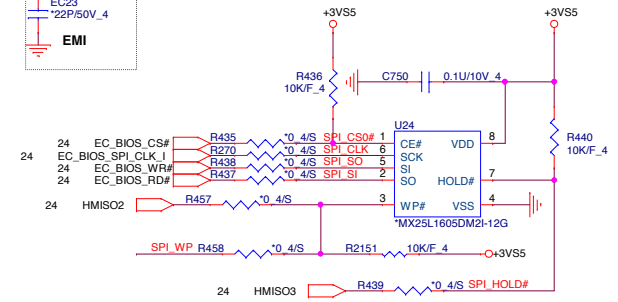
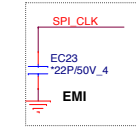

un-mount

**PROJECT :U99**  
 Quanta Computer Inc.

Size	Document Number	Rev
	<b>SATA/CLK (4/6)</b>	<b>1A</b>
Date:	Monday, May 19, 2014	Sheet 5 of 33



1.5V (3A)

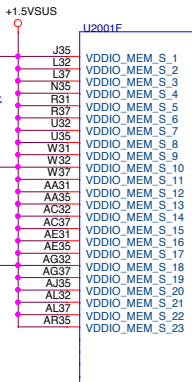
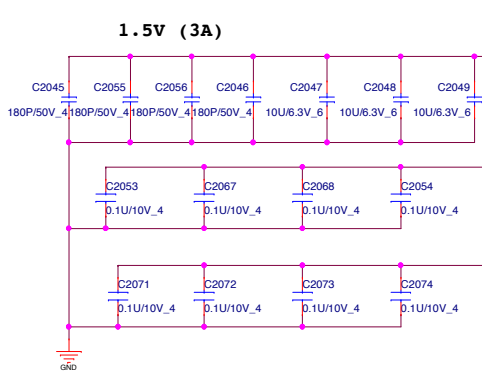

21A

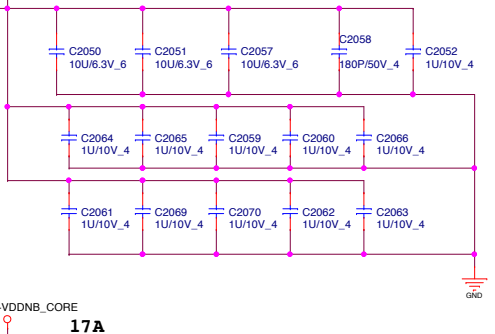

17A

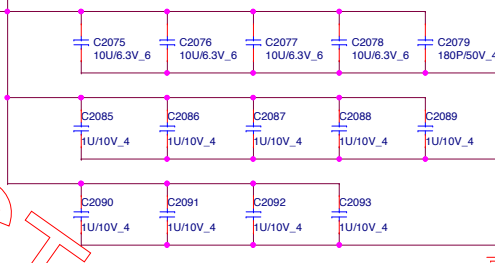

1.5A

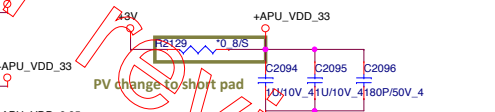

0.2A



0.6A

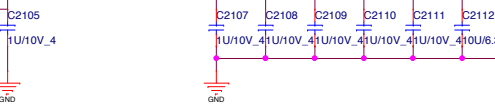

42R



U2001G

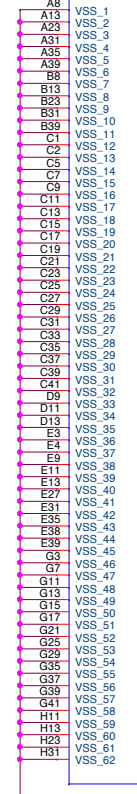

U2001H

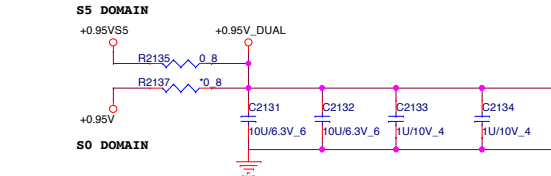
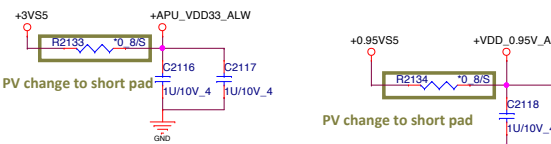
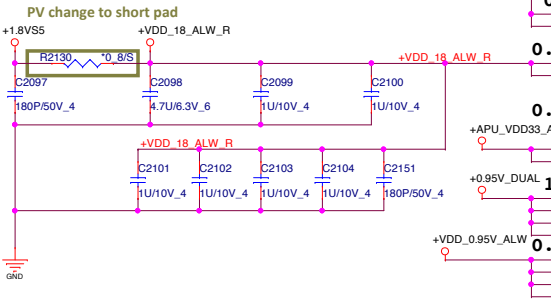
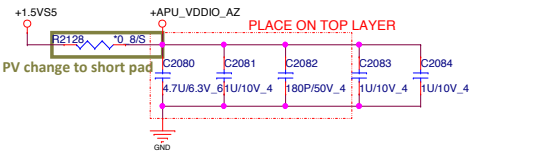
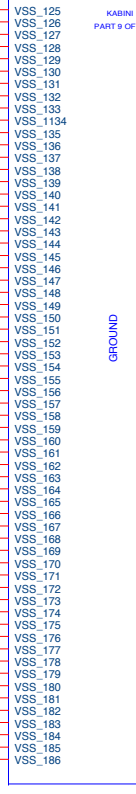

POWER

KABINI PART 7 OF 9

BEEMA

GROUND

BEEMA

BEEMA

GROUND

BEEMA

2,8,9,28,31,33	+1.5VSUS
27	+1.5VSS
4,5,7,23,24,26,27,31,33	+3VSS5
3,4,5,8,9,10,16,17,18,19,20,21,22,23,24,29,31,32,33	+3V
3,29,31	+1.8V
4,7,27,28,29,31,33	+1.8VSS
2,5,27	+0.95V
27	+0.95VSS



PROJECT :U99  
Quanta Computer Inc.

Size	Document Number	Rev
	<b>POWER/GND(5/6)</b>	1A
Date:	Monday, May 19, 2014	Sheet 6 of 33

# STRAPS PINS

OVERLAP COMMON PADS WHERE POSSIBLE FOR DUAL-OP RESISTORS.

# DEBUG STRAPS

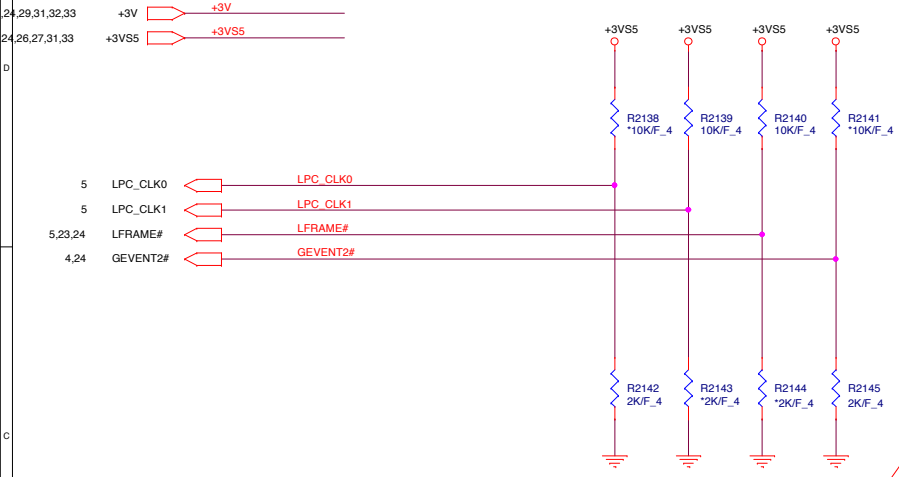



## REQUIRED STRAPS

					LPC_CLK0	LPC_CLK1	LFRAME#	GEVENT2#
PULL HIGH					BOOT FAIL TIMER ENABLED	CLKGEN ENABLED DEFAULT	SPI ROM DEFAULT	1.8V SPI ROM
PULL LOW					BOOT FAIL TIMER DISABLED DEFAULT	CLKGEN DISABLED	LPC ROM	3.3V SPI ROM DEFAULT

ICM review

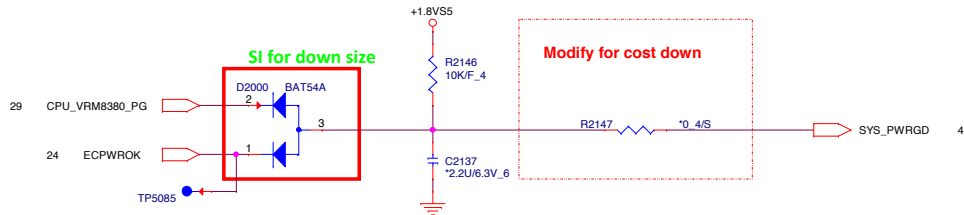
# SYS\_PWRGD



	<b>PROJECT :U99</b> Quanta Computer Inc.		
	Size	Document Number	Rev
		<b>STRAP (6/6)</b>	1A
Date: Monday, May 19, 2014   Sheet 7 of 33			

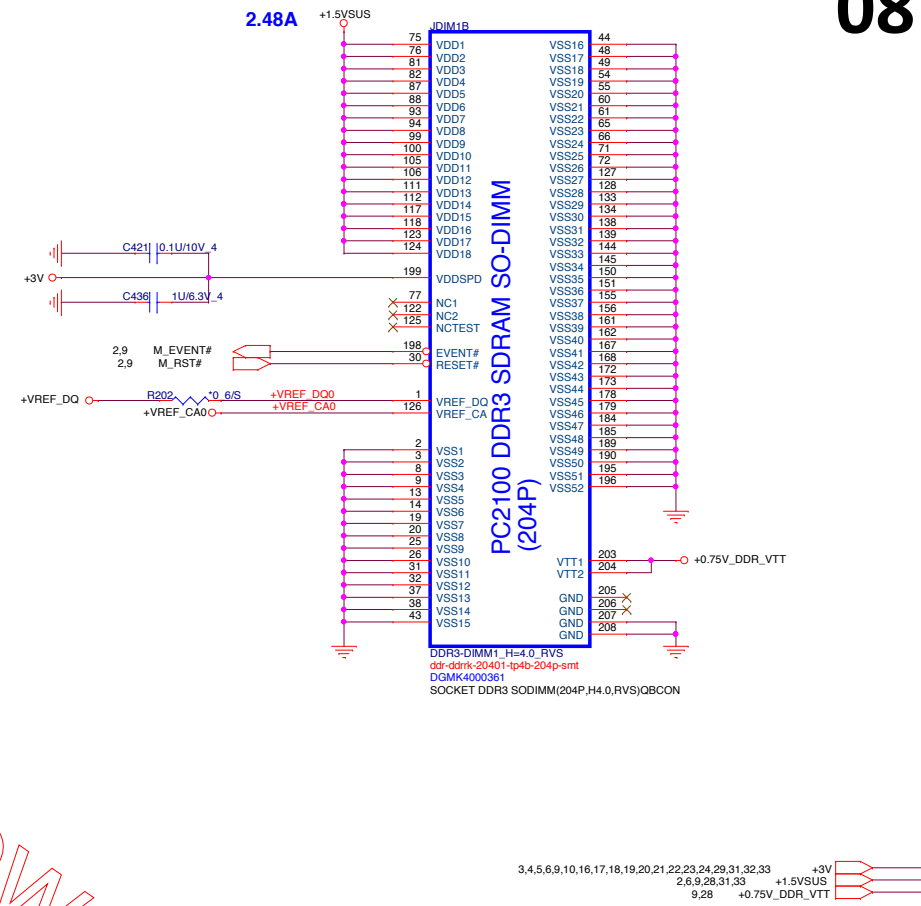
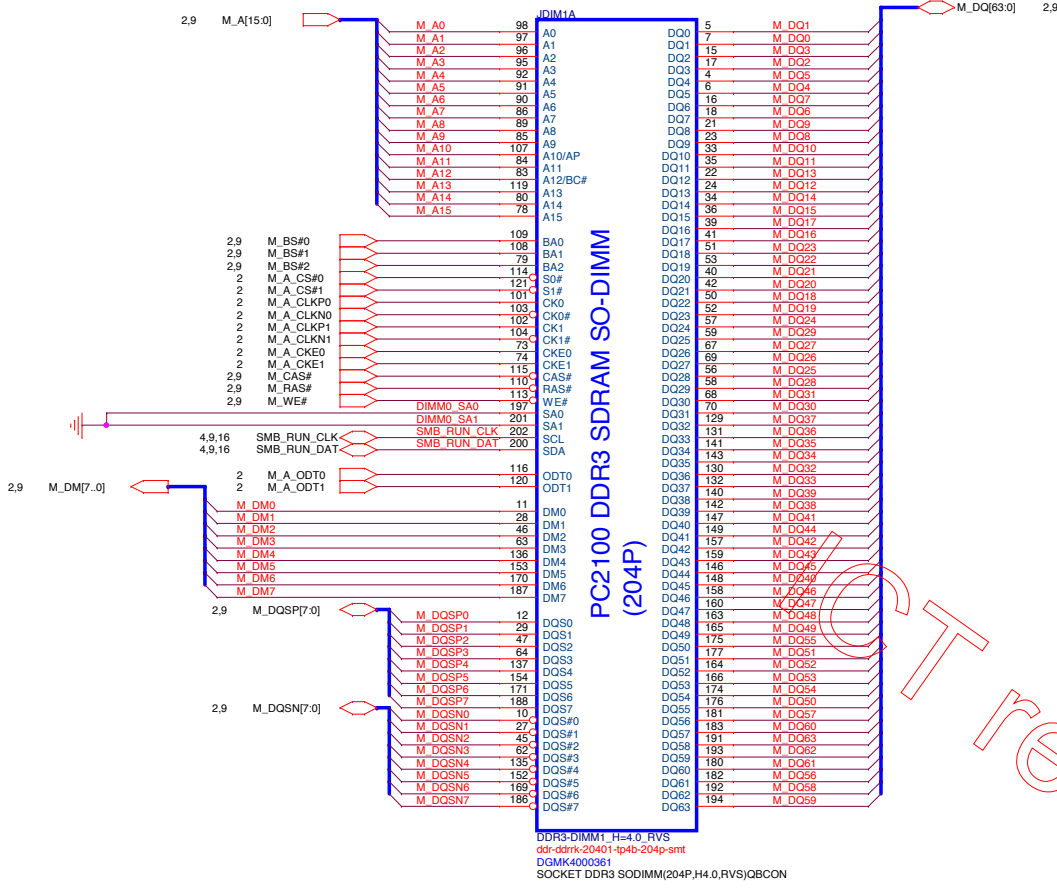

Place these Caps near So-Dimm0.

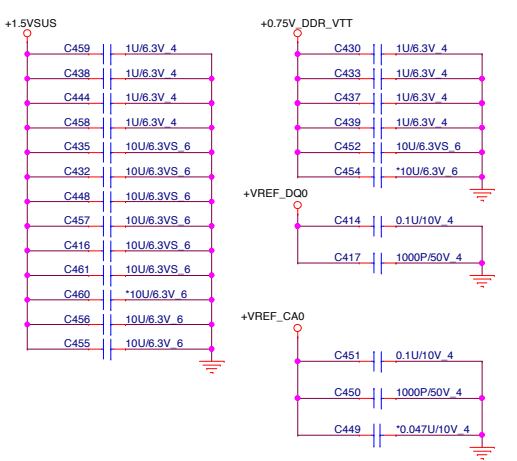

For EMI RESERVE

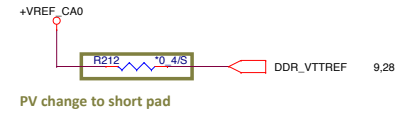
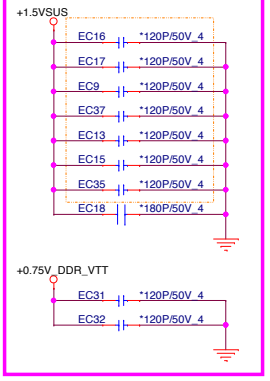

Reserved for AMD suggest

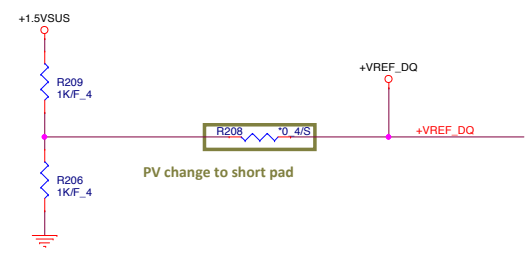

			<b>PROJECT :U99</b>	
			Quanta Computer Inc.	
Size	Document Number			Rev
Custom	System Memory 1/2 (5.2H)			1A
Date:	Monday, May 19, 2014	Sheet	8 of	33



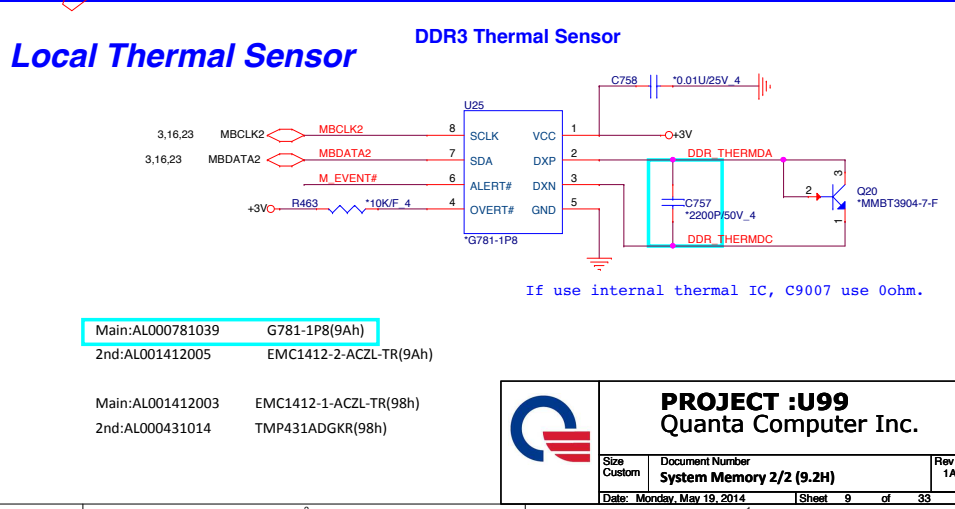
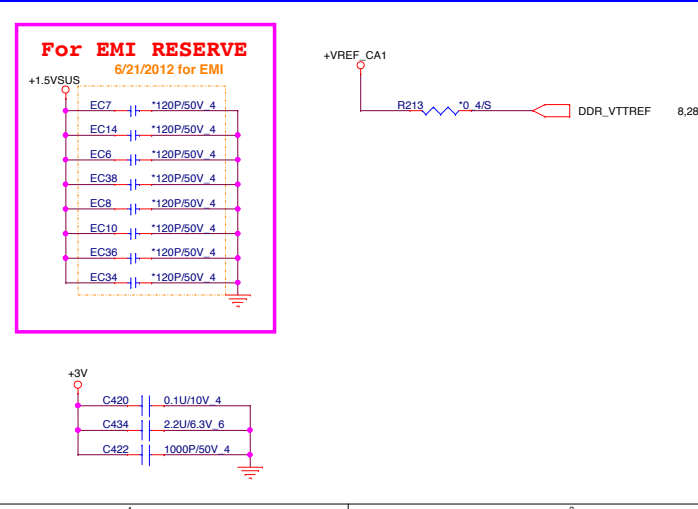
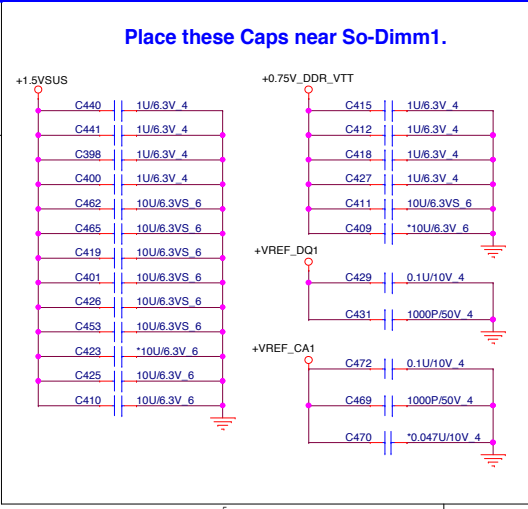
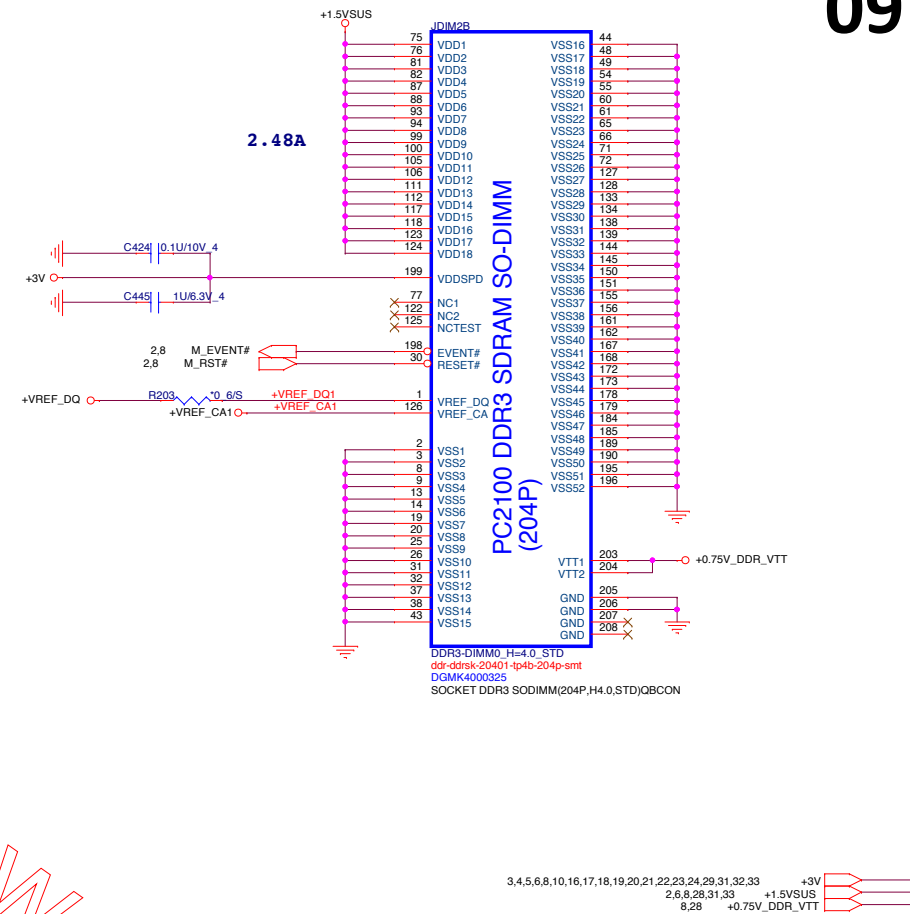
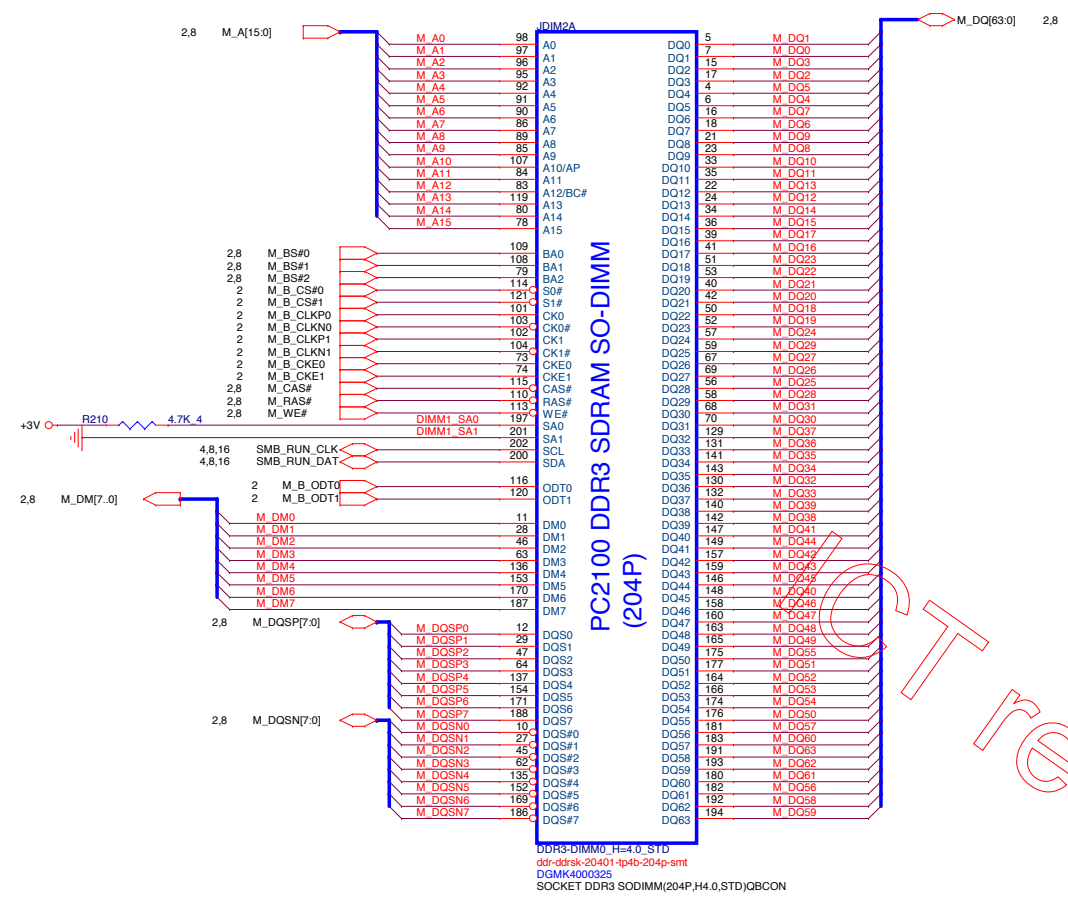

**PROJECT :U99**  
**Quanta Computer Inc.**

Size	Document Number	Rev
Custom	System Memory 2/2 (9.2H)	1A
Date: Monday, May 19, 2014	Sheet 9 of 33	

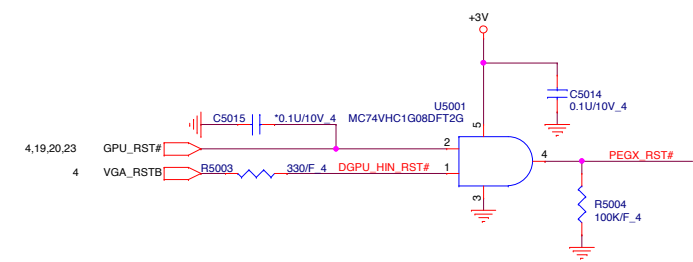
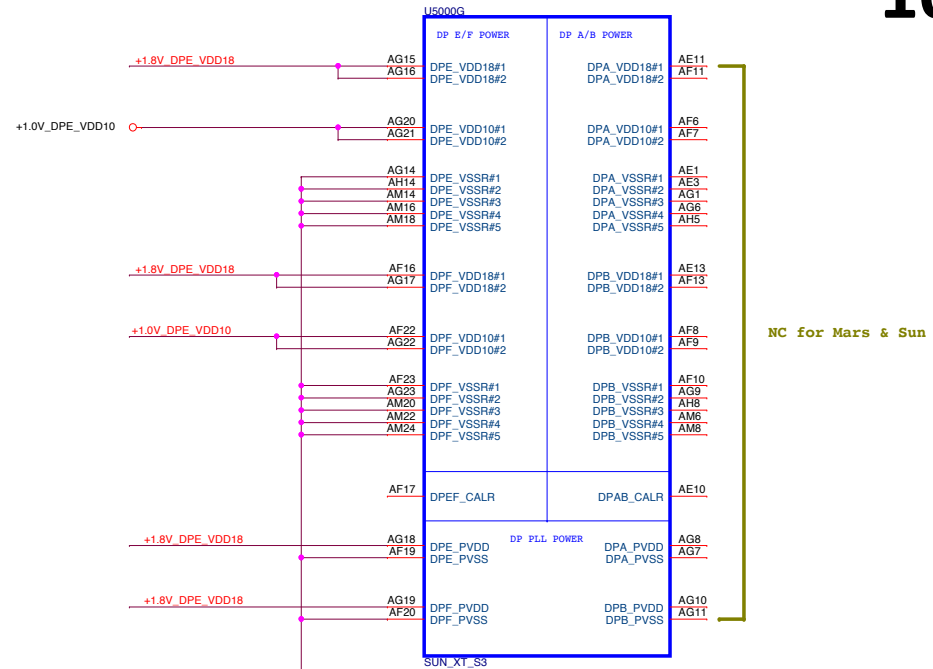
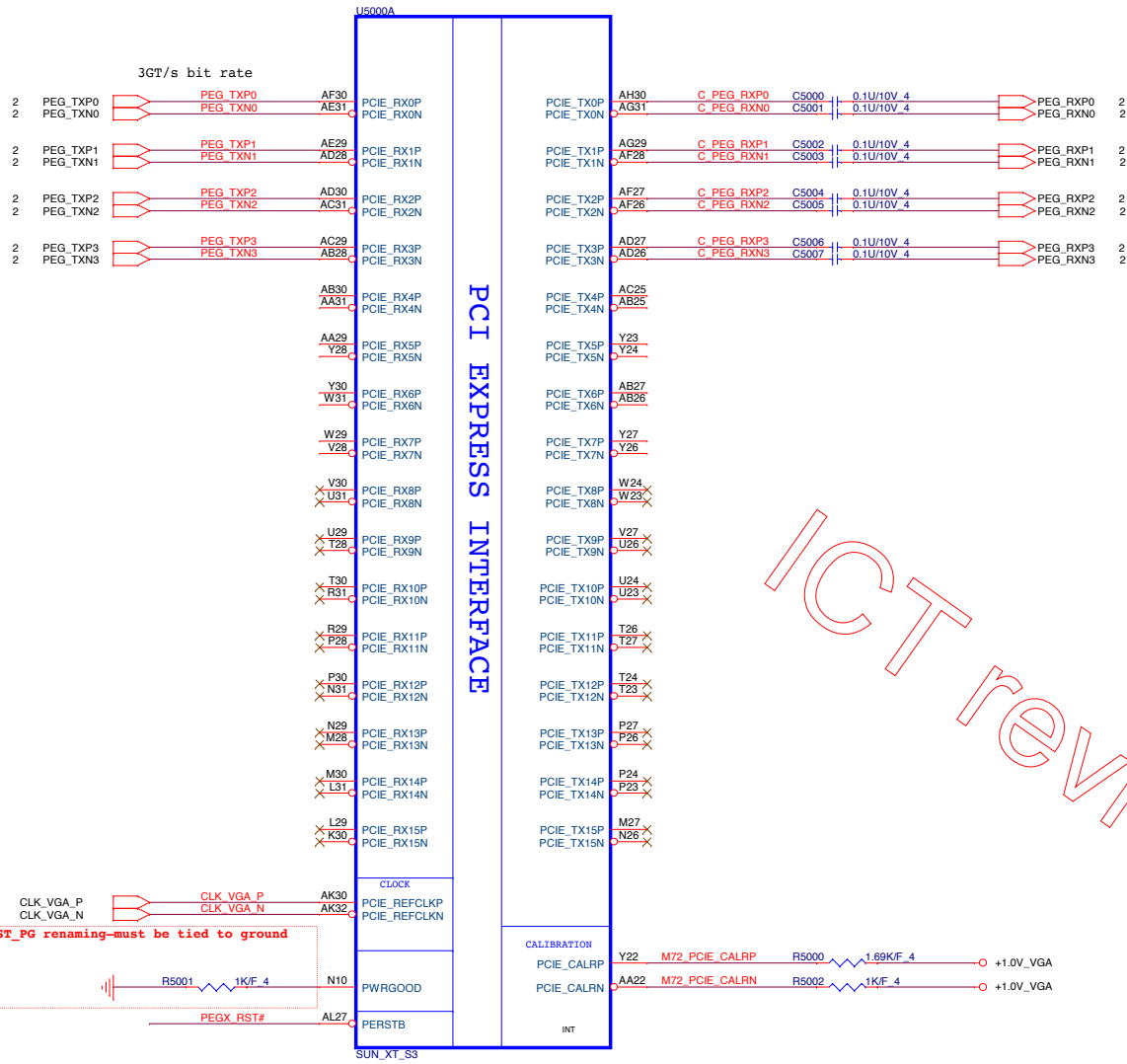

ICT review

+1.0V\_VGA 11:13.33  
+1.8V\_VGA 11:13,23,33

**PROJECT :U99**  
**Quanta Computer Inc.**

Size Custom	Document Number Sun S3 PCIe Interface	Rev 1A
Date: Monday, May 19, 2014		
Sheet 10 of 33		

GPIO10	GPIO30	GPIO16	GPIO20	GPIO15	Sun XT FS
PWRCNTL5	PWRCNTL4	PWRCNTL3	PWRCNTL2	PWRCNTL1	V-CORE
0	1	1	0	1	1.175V
0	1	1	1	0	1.150V
0	1	1	1	1	1.125V
1	0	0	0	0	1.100V
1	0	0	0	1	1.075V
1	0	0	1	0	1.050V
1	0	0	1	1	1.025V
1	0	1	0	0	1.000V
1	0	1	1	0	0.975V
1	0	1	1	1	0.950V
1	1	0	0	0	0.900V
1	1	0	0	1	0.875V
1	1	0	1	0	0.850V
1	1	0	1	1	0.825V
1	1	1	0	0	0.800V
1	1	1	0	1	0.775V

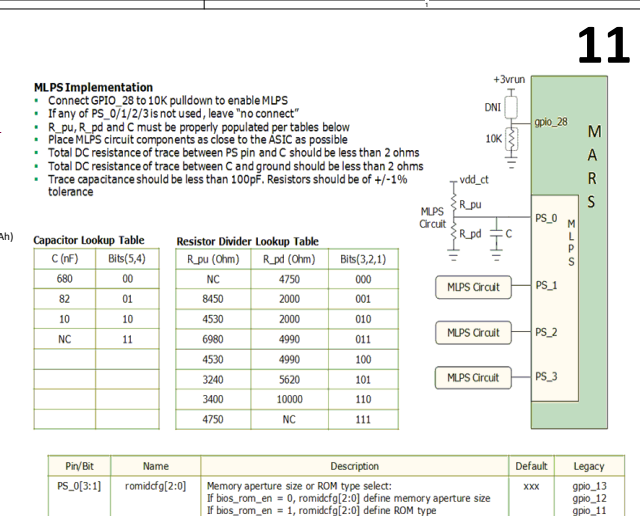
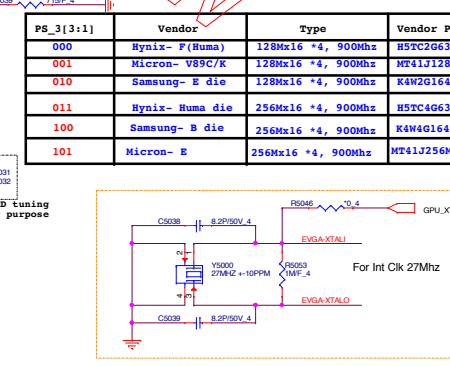
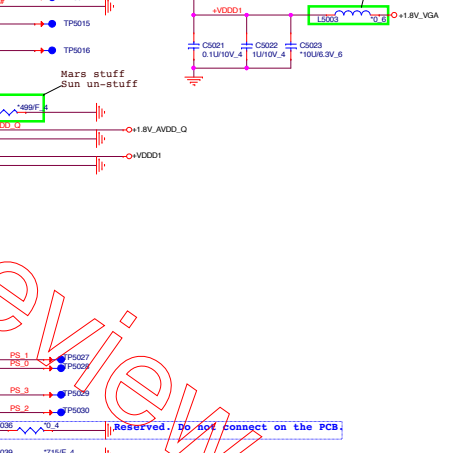
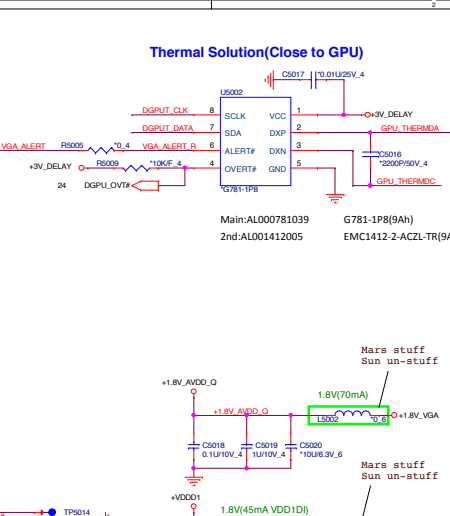
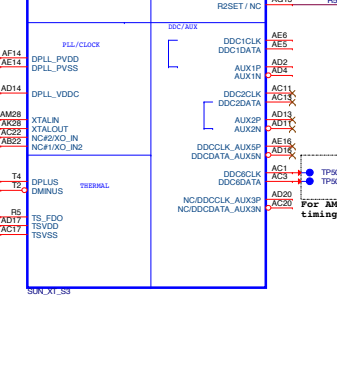
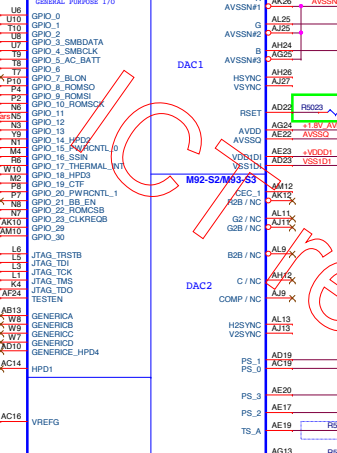
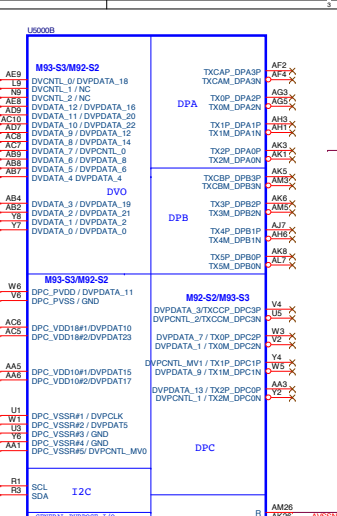
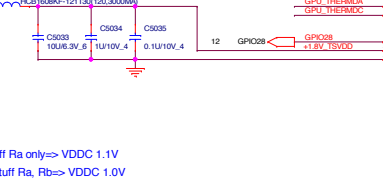
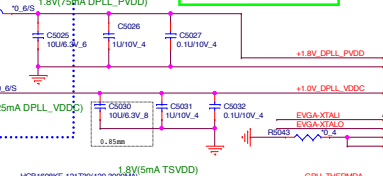
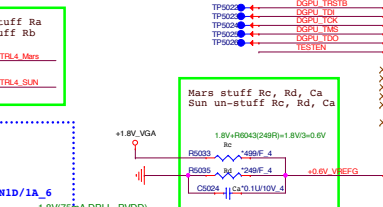
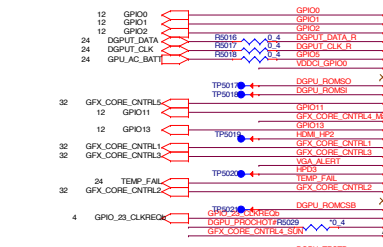
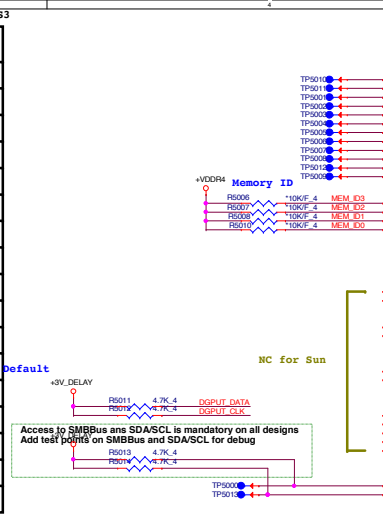

Pin/Bt	Name	Description	Default	Legacy
PS_0[3:1]	romidcf[2:0]	Memory aperture size or ROM type select: If bios_rom_en = 0, romidcf[2:0] define memory aperture size If bios_rom_en = 1, romidcf[2:0] define ROM type	xxx	gpio_13 gpio_12 gpio_11
PS_0[4]	n/a	Reserved	1	genk_vsync
PS_1[1]	bif_gen3_en_a	PCIe Gen3 capability: 1=Gen3 supported, 0=Gen3 not supported	x	gpio_2
PS_1[2]	bif_clk_pm_en	PCIe CLK PM capability: 1 = CLKREQB supported	x	gpio_8
PS_1[3]	n/a	Reserved		genk_clk
PS_1[4]	tx_pwr_s_erb	PCIe Tx power savings: 0=50% swing, 1=full swing	x	gpio_0
PS_1[5]	tx_deemph_en	PCIe Tx de-emphasis: 1=Tx de-emphasis enabled	x	gpio_1
PS_2[1]	n/a	Reserved		n/a
PS_2[2]	n/a	Reserved		n/a
PS_2[3]	bios_rom_en	Enable external BIOS ROM: 1=External ROM connected	x	gpio_22
PS_2[4]	vga_dis	VGA disable: 1=Disable this GPU as the system's VGA controller	0	gpio_9
PS_2[5]	n/a	Reserved		n/a
PS_3[1]	MEM Vendor ID	MEM Vendor ID	0	n/a
PS_3[2]	MEM Vendor ID	MEM Vendor ID	0	n/a
PS_3[3]	MEM Vendor ID	MEM Vendor ID	0	n/a
PS_3[5]	aud_port_cp[2]	3-bit field indicating number of audio-capable display outputs	xxx	n/a
PS_3[4]	aud_port_cp[1]			
PS_3[0]	aud_port_cp[0]			

PS_3[3:1]	Vendor	Type	Vendor P/N	R5045	R5048
000	Hynix - F (Huma)	128Mx16 *4, 900Mhz	H57C2G63PFR-11C	NC	4.75K
001	Micron - V89C/R	128Mx16 *4, 900Mhz	MT41J128M16J8-093G:K	8.45K	2K
010	Samsung- B die	128Mx16 *4, 900Mhz	K4W2G1646B-BC1A	4.53K	2K
011	Hynix - Huma die	256Mx16 *4, 900Mhz	H57C4G63FAPR-11C	6.98K	4.99K
100	Samsung- B die	256Mx16 *4, 900Mhz	K4W4G1646B-HC1A	4.53K	4.99K
101	Micron - E	256Mx16 *4, 900Mhz	MT41J256M16HA-093G:E	3.24K	5.62K

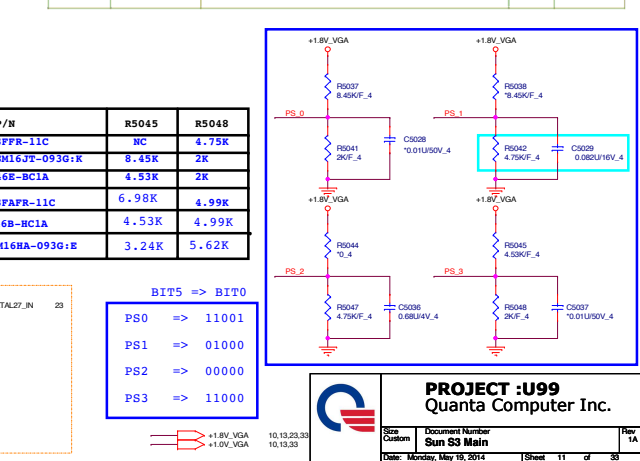

PROJECT :U99  
Quanta Computer Inc.

BIT5 => BIT0

PS0 => 11001  
PS1 => 01000  
PS2 => 00000  
PS3 => 11000

Doc Custom    Document Number: Sun SS Main    Rev 1A  
Date: Monday, May 19, 2014    10.19.23.33    10.19.33    Sheet 11 of 30

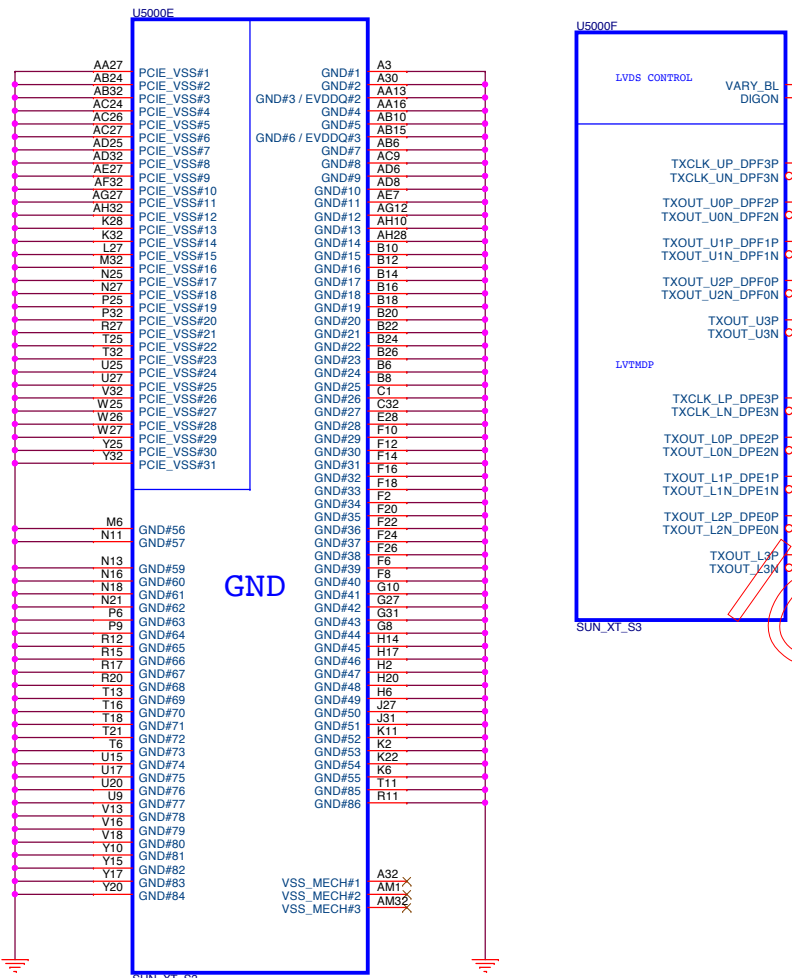

**CONFIGURATION STRAPS-- SEE EACH DATABOOK FOR STRAP DETAILS**  
**ALLOW FOR PULLUP PADS FOR THESE STRAPS AND IF THESE GPIOs ARE USED, THEY MUST NOT CONFLICT DURING RESET**

STRAPS	PIN	DESCRIPTION OF DEFAULT SETTINGS	RECOMMENDED SETTINGS
TX_PWRs_ENB	GPIO0	PCIE FULL TX OUTPUT SWING	0
TX_DEEMPH_EN	GPIO1	PCIE TRANSMITTER DE-EMPHASIS ENABLED	0
RSVD	GPIO2	RESERVED	X
RSVD	GPIO8	RESERVED	0
BIF_VGA_DIS	GPIO9	VGA ENABLED	0
RSVD	GPIO21	RESERVED	0
BIOS_ROM_EN	GPIO22_ROMCSB	ENABLE EXTERNAL BIOS ROM	0
ROMIDCFG(2:0)	GPIO[13:1]	SERIAL ROM TYPE OR MEMORY APERTURE SIZE SELECT	0 0 1
VIP_DEVICE_STRAP_ENA	V2SYNC	IGNORE VIP DEVICE STRAPS (Removed on Seymour/Whistler)	0
RSVD	H2SYNC	RESERVED	0
AUD[1] AUD[0]	HSYNC VSYNC	SEE DATABOOK FOR DETAIL SEE DATABOOK FOR DETAIL	0 0
RSVD	GENERICC	RESERVED	0

**NOTE1: AMD RESERVED CONFIGURATION STRAPS**  
**ALLOW FOR PULLUP PADS FOR THESE STRAPS BUT DO NOT INSTALL RESISTOR. IF THESE GPIOs ARE USED, THEY MUST KEEP "LOW" AND NOT CONFLICT DURING RESET.**

GPIO21	H2SYNC	GENERICC	GPIO8	GPIO2
--------	--------	----------	-------	-------

**Power Up/Down Sequence**

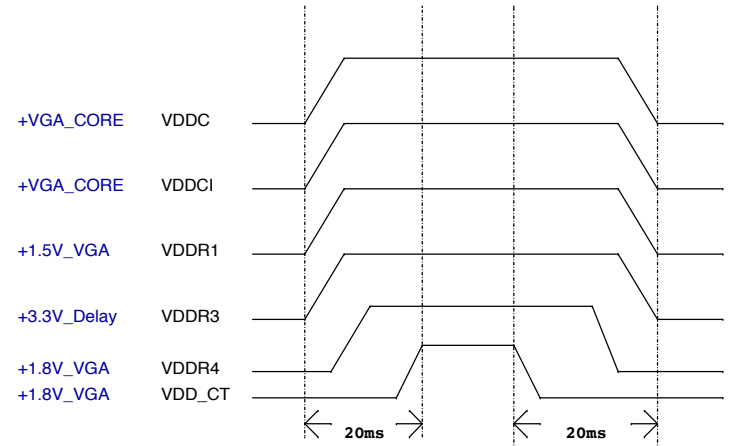

**Memory Aperture size(Seymour)**

GPIO9 BIOSROM	GPIO13 ROMIDCFG2	GPIO12 ROMIDCFG1	GPIO11 ROMIDCFG0
0	128M	0	0
0	256M	0	1
0	64M	0	0
0	32M	0	1
0	512M	1	0
0	1G	1	1
0	2G	1	0
0	4G	1	1

It is a shared pin strap with CONFIG[2:0] if BIOS\_ROM\_EN is set to 0.

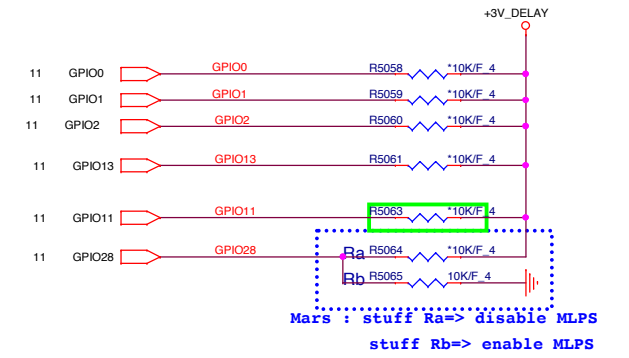

**PROJECT :U99**  
**Quanta Computer Inc.**

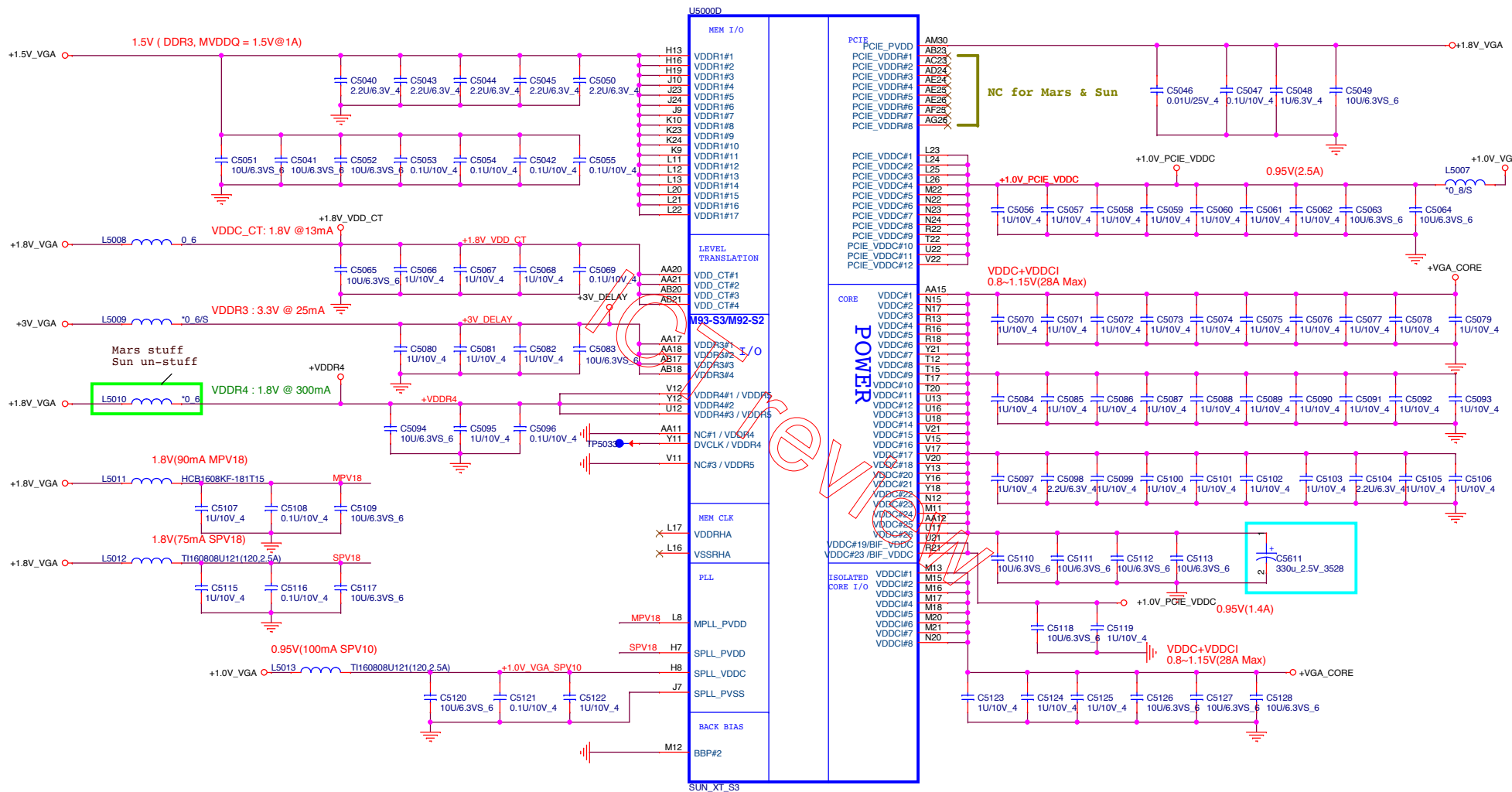

+1.5V_VGA	14,15,33
+1.8V_VGA	10,11,23,33
+1.0V_VGA	10,11,33
+VGA_CORE	32,33
+3V	3,4,5,6,8,9,10,16,17,18,19,20,21,22,23,24,29,31,32,33
+5V	17,18,21,22,31

	<b>PROJECT :U99</b> Quanta Computer Inc.	
	Size Custom Document Number <b>Sun S3 Power_and_NC</b>	Rev 1A
Date: Monday, May 19, 2014   Sheet 13 of 33		

MEMORY INTERFACE

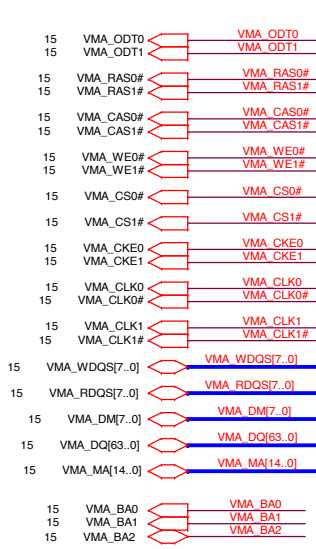

support 1Gbit  
VRAM ( 64M X 16 )

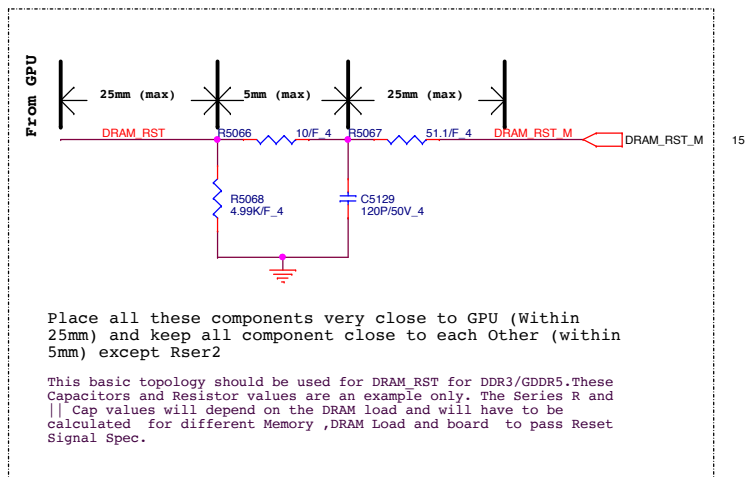
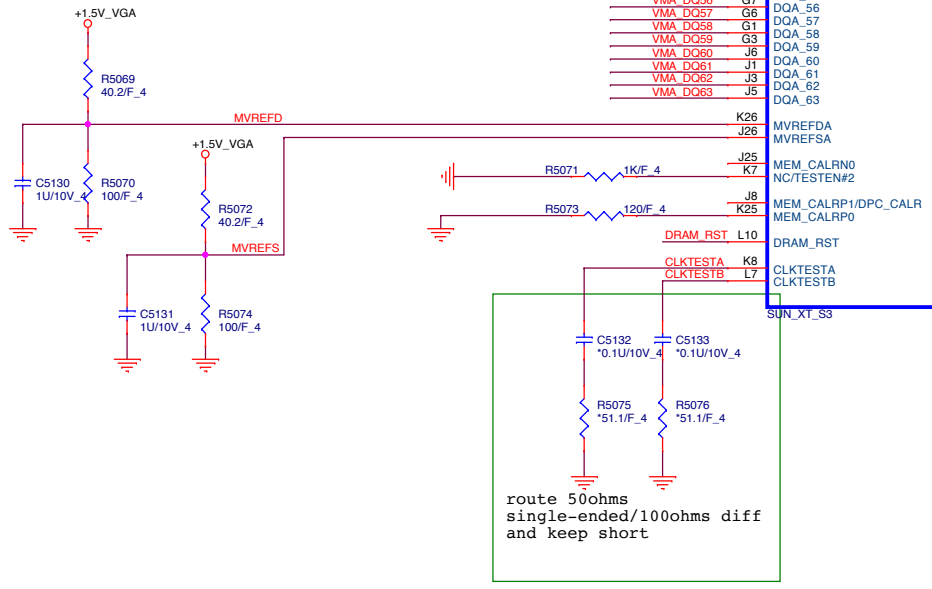
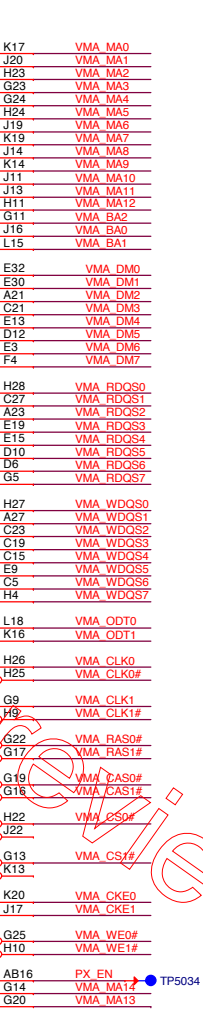
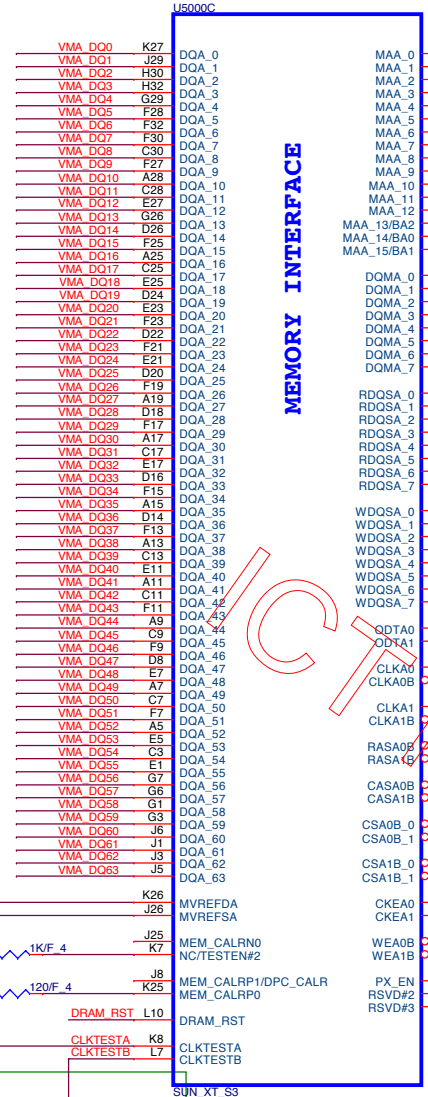

Place all these components very close to GPU (Within 25mm) and keep all component close to each Other (within 5mm) except Rser2

This basic topology should be used for DRAM\_RST for DDR3/GDDR5. These Capacitors and Resistor values are an example only. The Series R and || Cap values will depend on the DRAM load and will have to be calculated for different Memory, DRAM Load and board to pass Reset signal Spec.



**PROJECT :U99**  
Quanta Computer Inc.

Size Custom	Document Number <b>Sun S3 MEM Interface</b>	Rev 1A
Date: Monday, May 19, 2014	Sheet 14 of 38	



# 1G DDR3

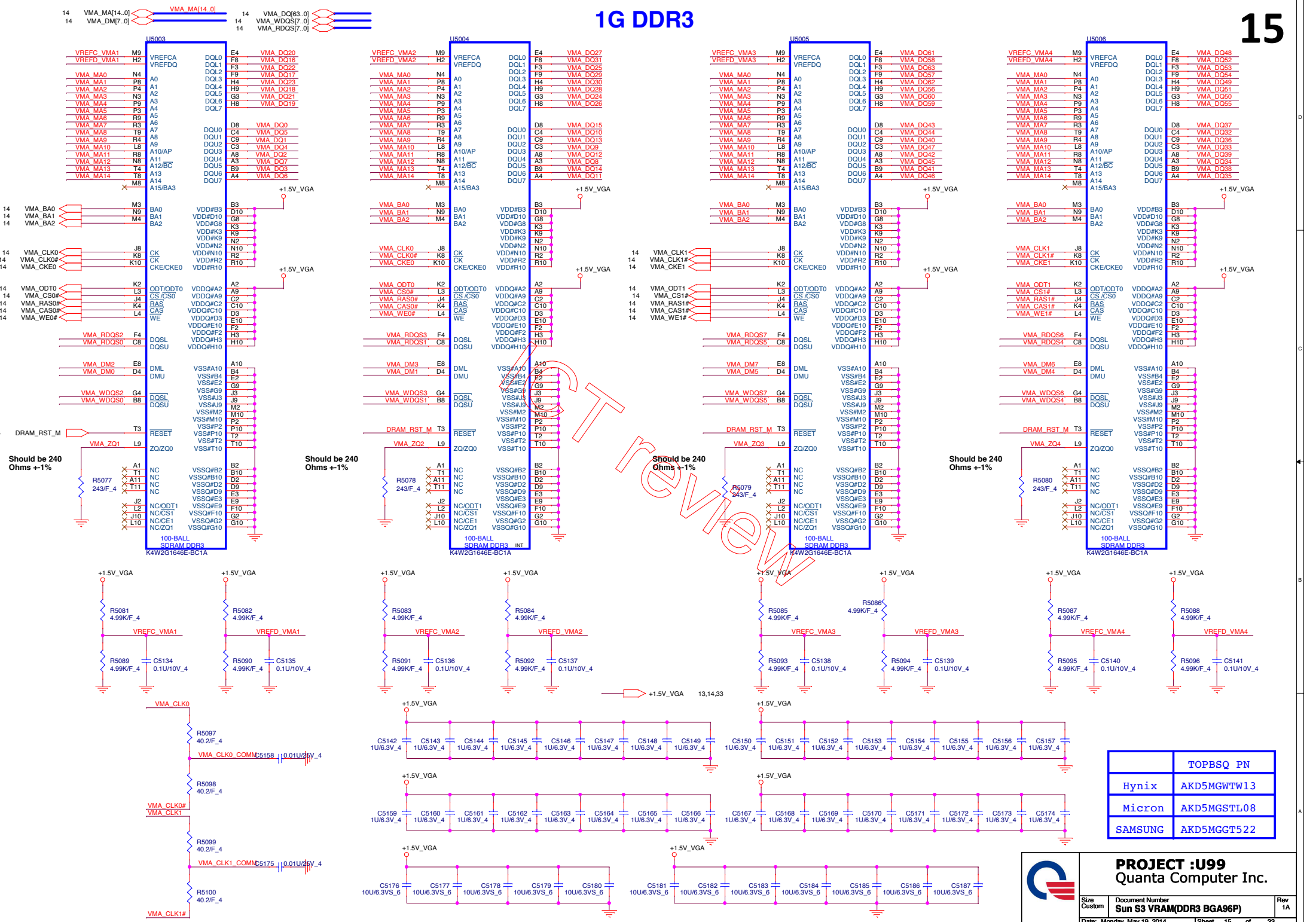

TOPBQ PN
Hynix AKD5MGWTW13
Micron AKD5MGSTL08
SAMSUNG AKD5MGGT522

**PROJECT :U99**  
**Quanta Computer Inc.**

Size Custom	Document Number Sun S3 VRAM(DDR3 BGA96P)	Rev 1A
Date: Monday, May 19, 2014	Sheet 15 of 33	

for Bemma LVDS need stuff 0.1u cap ; need change 0.1u on next stage

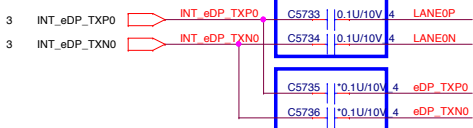

Bemba to LVDS Converter

From LVDS Converter

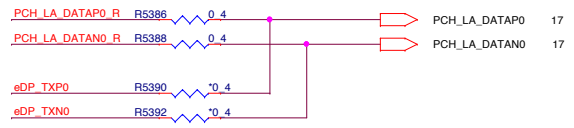

to Bemba eDP

from Bemba eDP

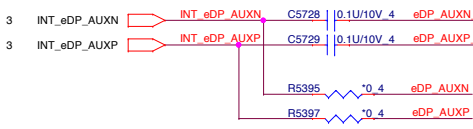

Bemba to LVDS Converter

From LVDS Converter

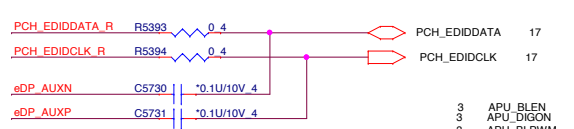

to Bemba eDP

from Bemba eDP

for Bemba eDP : stuff R5396 / R5398 / R5399  
for Bemba LVDS : Don't stuff R5396 / R5398 / R5399

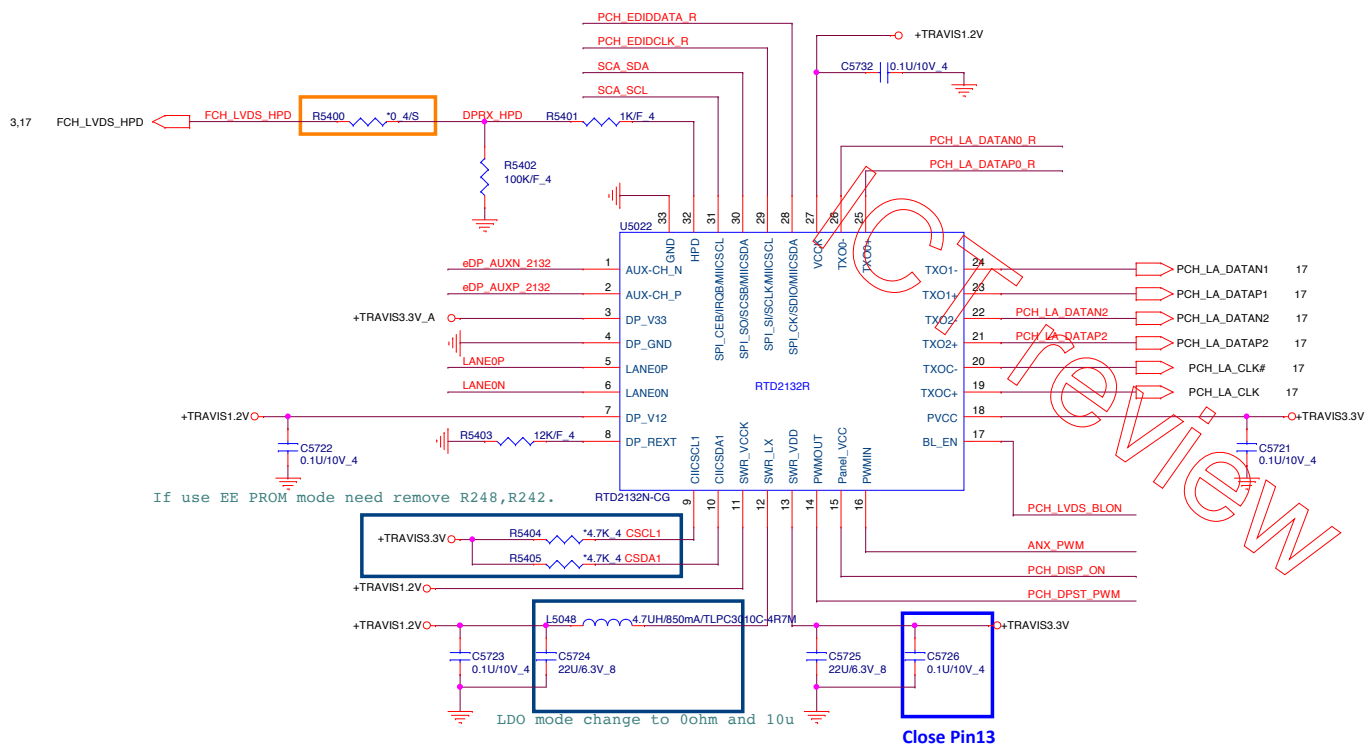
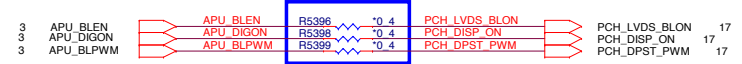

If use EE PROM mode need remove R248, R242.

LDO mode change to 0ohm and 10u

Close Pin13

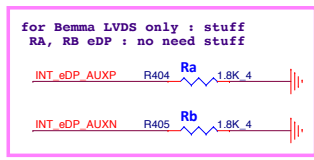
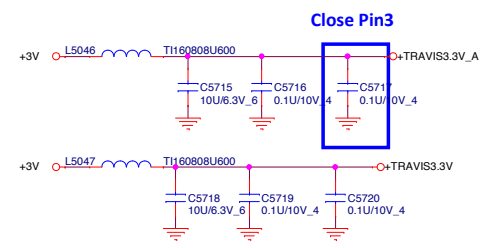

for Bemba LVDS only : stuff RA, RB eDP : no need stuff

INT\_eDP\_AUXP R404 Ra  
INT\_eDP\_AUXN R405 Rb

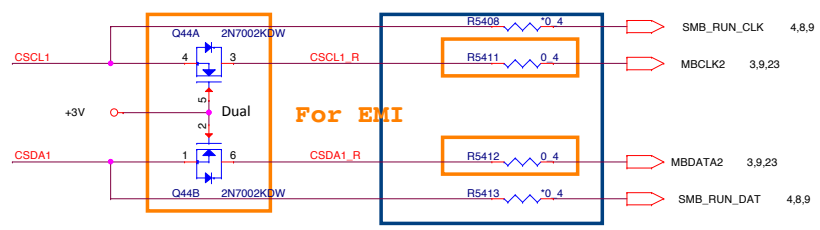
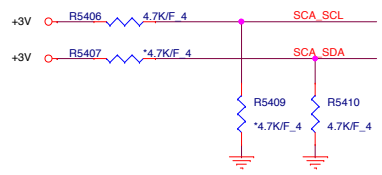
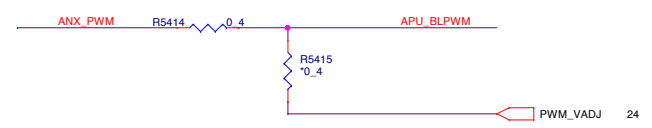

For EMI

EE PROM R5408, R5413  
EC OPTION R5411, R5412

		MODE_CFG0(PIN30)	
		0	1
MODE_CFG1(PIN31)	0	X	EP MODE
	1	ROM ONLY MODE	EEPROM MODE

**PROJECT :U99**  
Quanta Computer Inc.

Size Custom	Document Number <b>RTD2132S</b>	Rev 3A
Date: Monday, May 19, 2014		Sheet 16 of 33

# LVDS Conn.

for Bemma eDP : don't stuff Ra / Ca ;  
for Bemma LVDS : stuff Ra / Ca

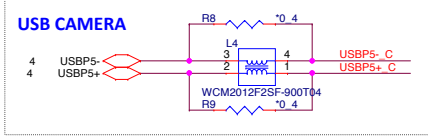
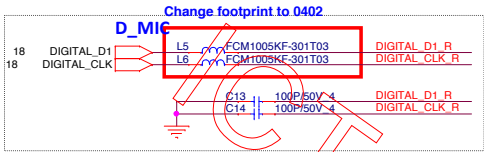
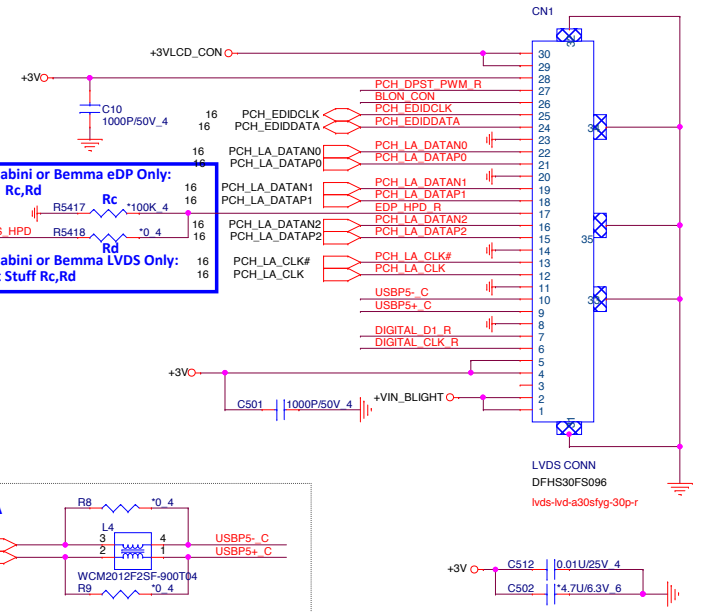
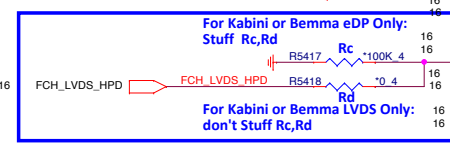
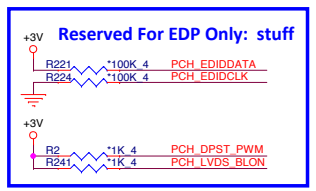
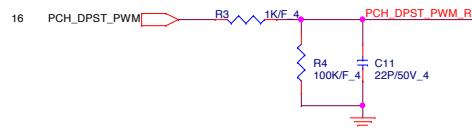
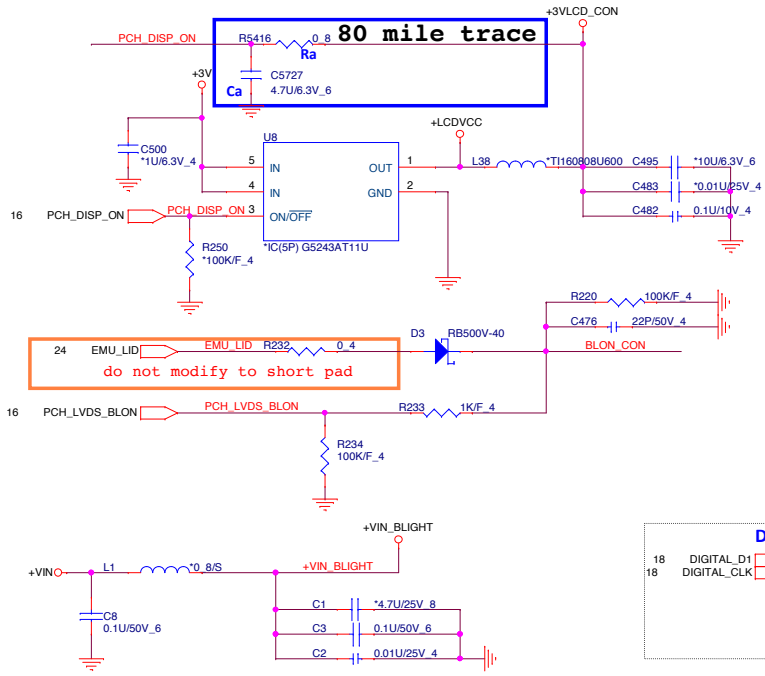

# HDMI Conn.

## HDMI SMBus Isolation

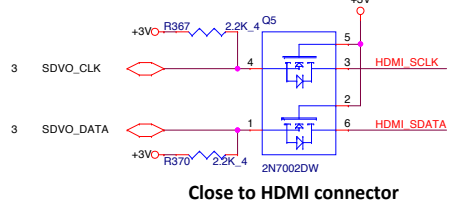

## EMI Solution

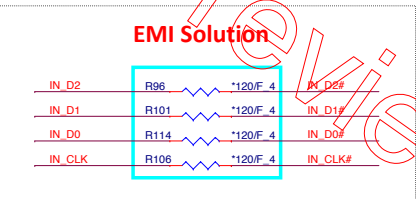

## HDMI HPD SENSE

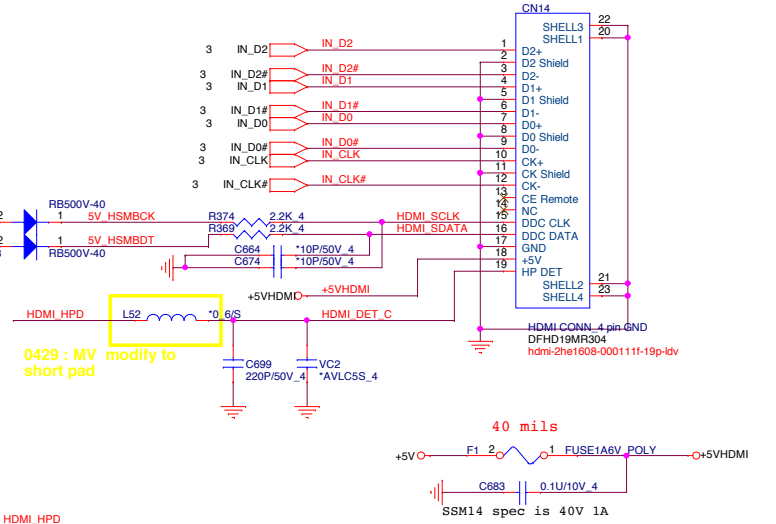
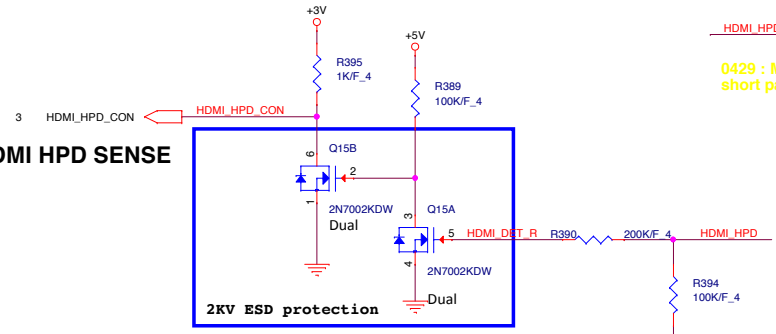

3,4,5,6,8,9,10,16,18,19,20,21,22,23,24,29,31,32,33	+3V
3,5,18,21,22,23,24,25,26	+3VPCU
18,21,22,31	+5V
21,25,26,27,28,30,31,32,33	+VIN
25,31,33	+12VALW
18,22,26,27,28,29,30,31,32	+5VSS

**PROJECT :U99**  
Quanta Computer Inc.

Size Custom	Document Number LCD Connector (LVDS)	Rev 3A
Date: Monday, May 19, 2014		Sheet 17 of 33

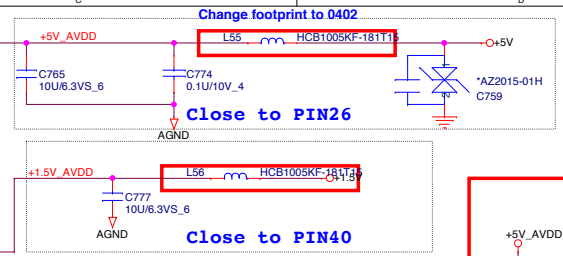
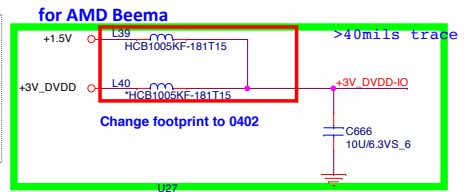
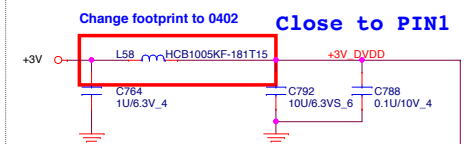

3,4,5,6,8,9,10,16,17,19,20,21,22,23,24,29,31,32,33,23,29,31

17,21,22,31

+5V

+3V

+1.5V

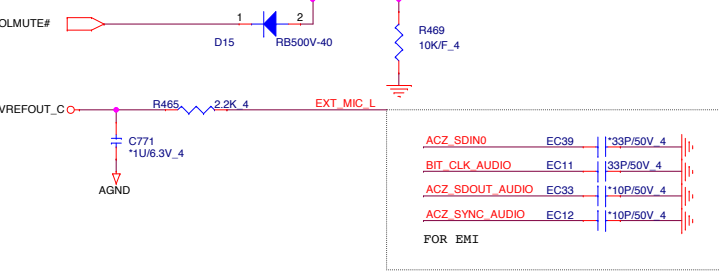
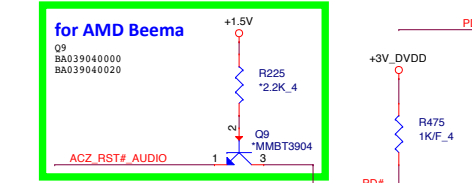
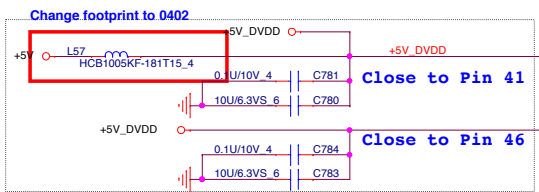
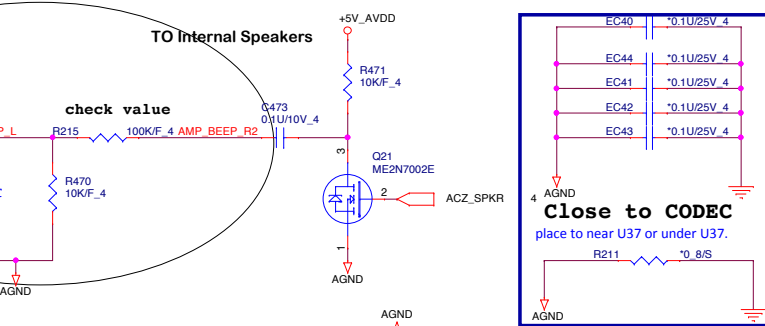
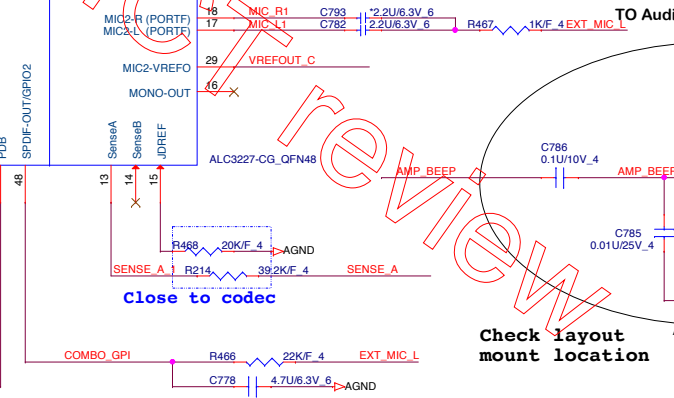
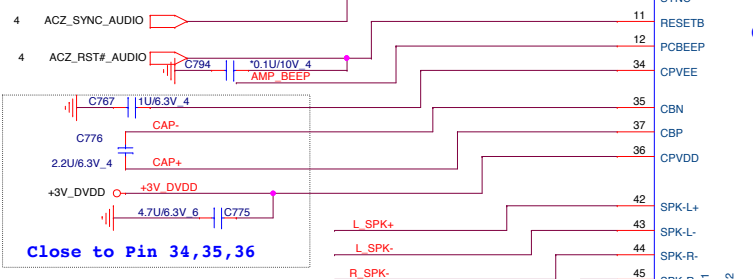
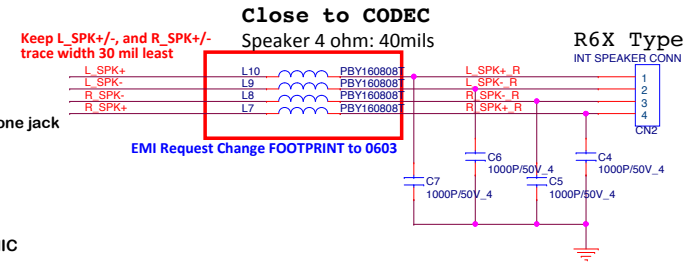
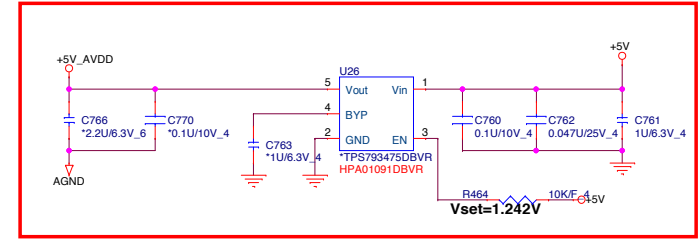
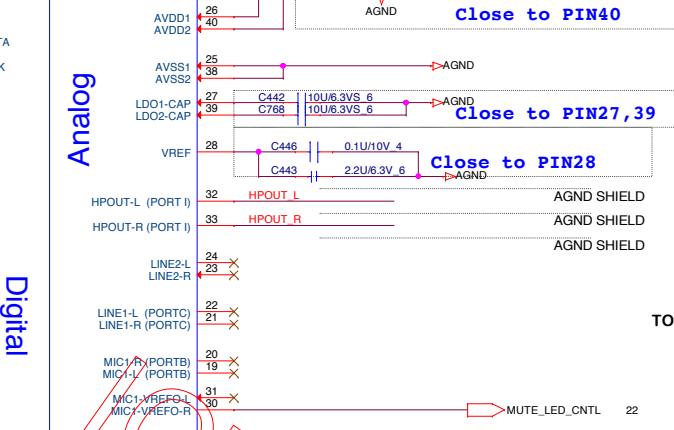
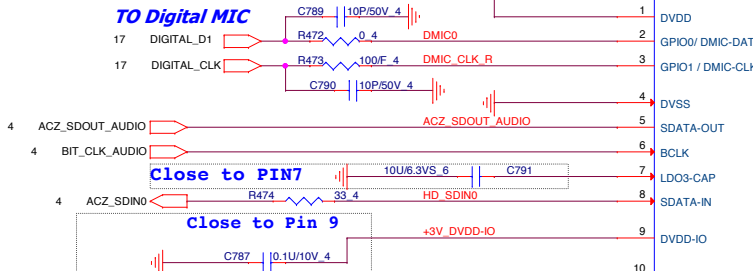

**USB 2.0 AND AUDIO COMBO JACK**

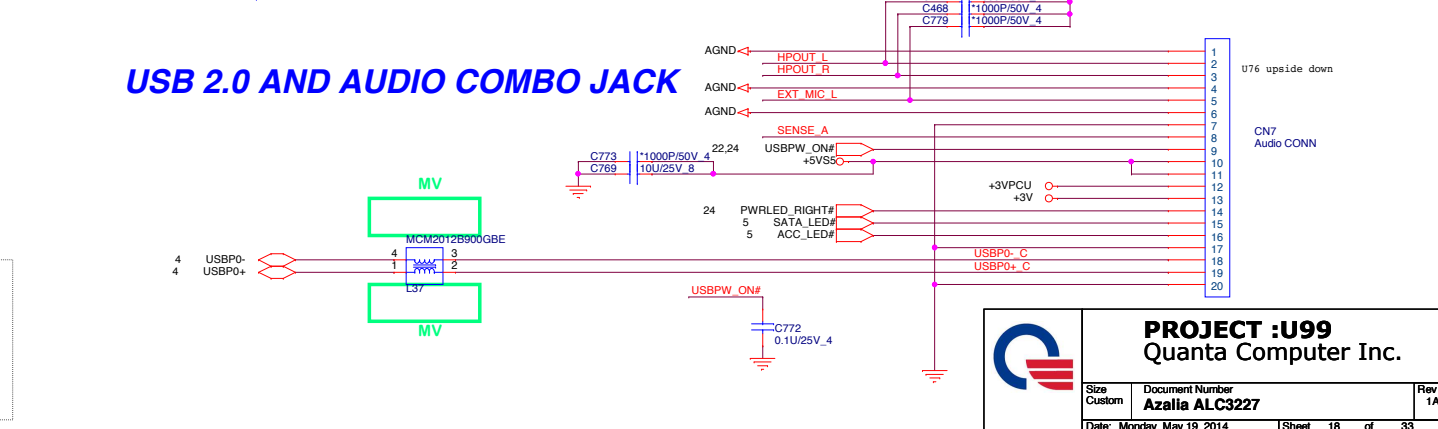

**PROJECT :U99**  
Quanta Computer Inc.

Size Custom	Document Number <b>Azalia ALC3227</b>	Rev 1A
Date: Monday, May 19, 2014	Sheet 18 of 33	

For EMI 0 - 22 ohm

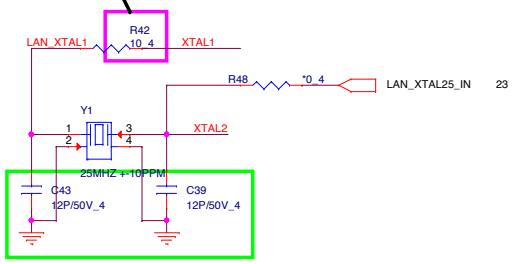

SI change to 12p

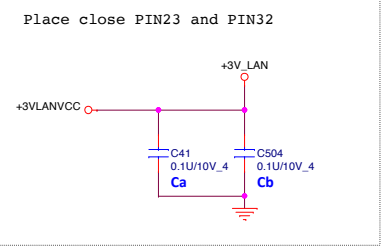
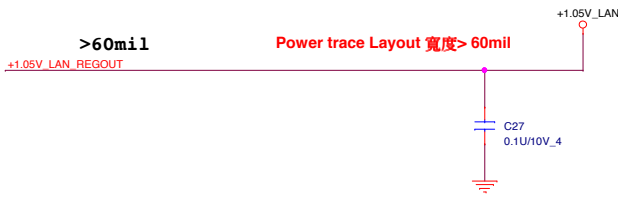

Place close PIN23 and PIN32

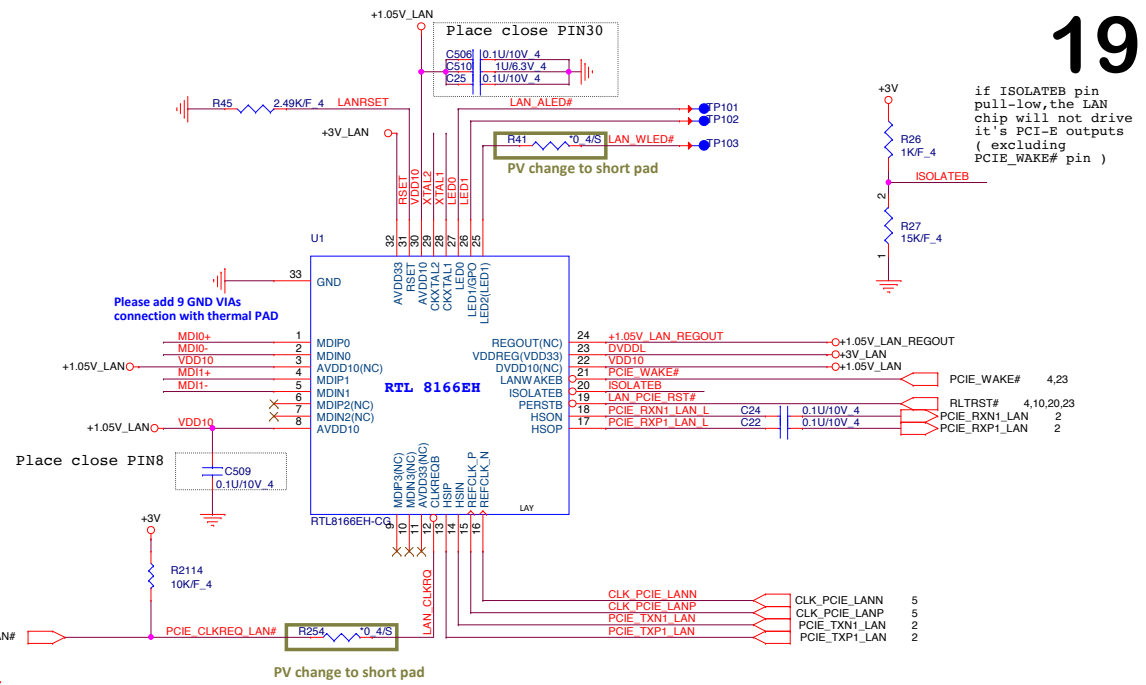

### LAN conn

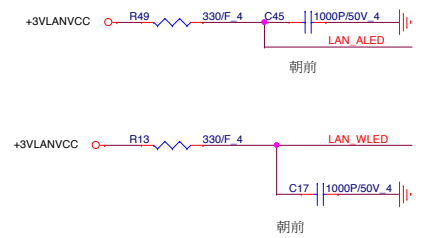
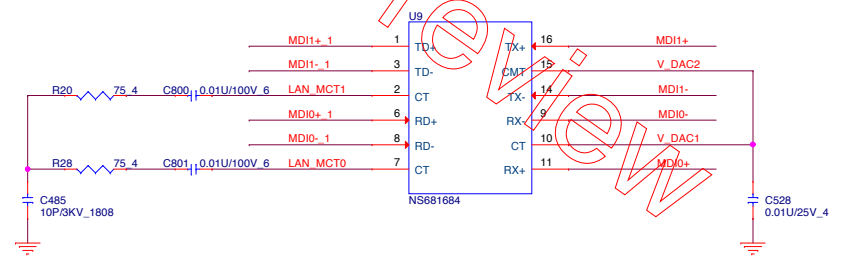
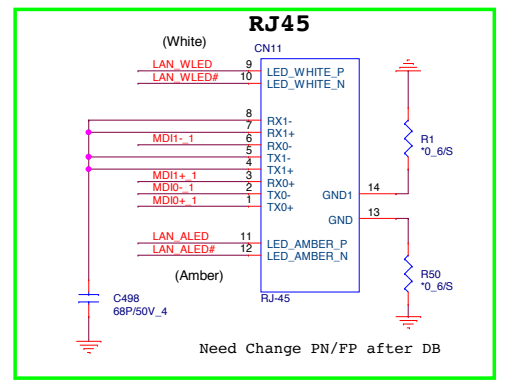

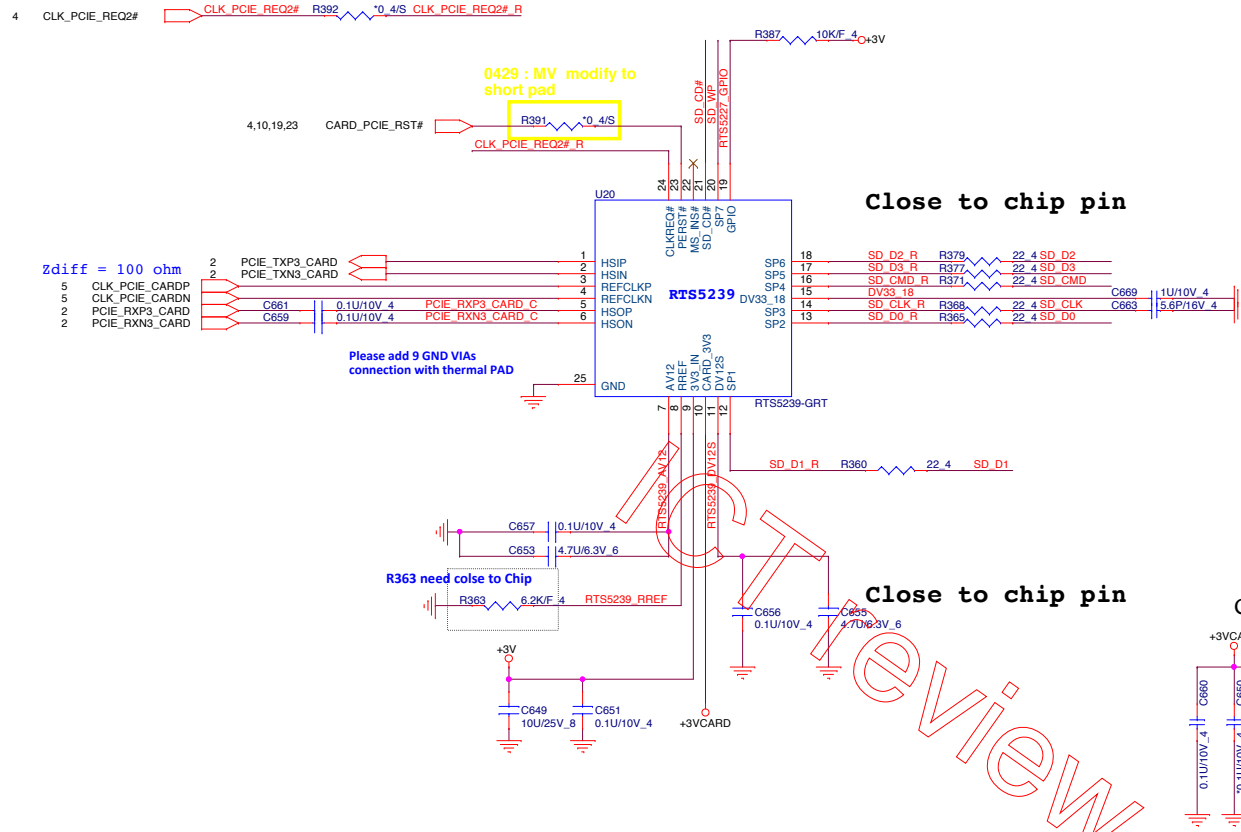

SP1	SD D1	MS D1
SP2	SD D0	MS D1
SP3	SD CLK	MS D0
SP4	SD CMD	MS D2
SP5	SD D3	MS D3
SP6	SD D2	MS CLK
SP7	SD WP	MS BS

Share Pin

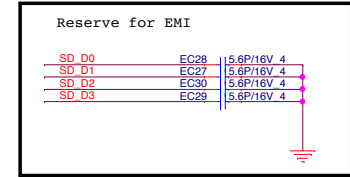

SD / MMC  
CARD READER

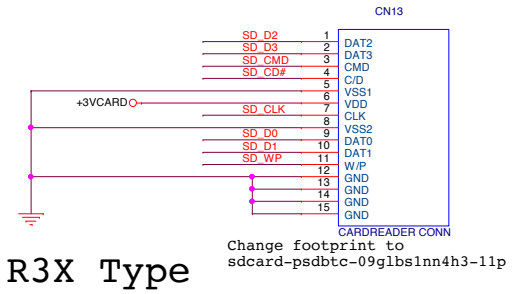

R3X Type

	<b>PROJECT :U99</b> Quanta Computer Inc.		Rev 1A	
	Size Custom	Document Number <b>RTS5239 &amp; CR SOCKET</b>		
	Date: Monday, May 19, 2014	Sheet 20 of 33		



### Power Button Connector

Pin1 : +3VPCU(LIDSWITCH PWR)  
 Pin2 : POWER LED  
 Pin3 : LIDSWITCH  
 Pin4 : GND  
 Pin5 : GND  
 Pin6 : POWERON#

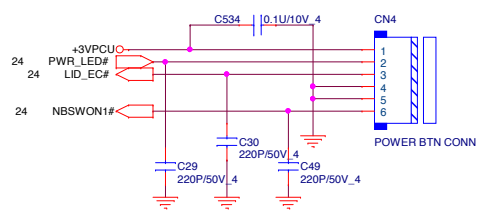

### CPU FAN

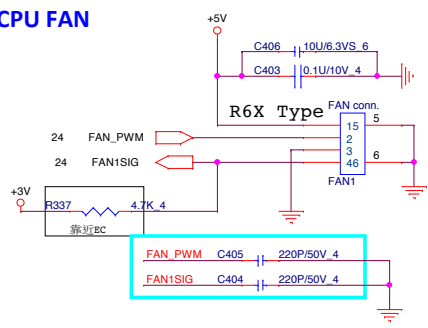

### Hole

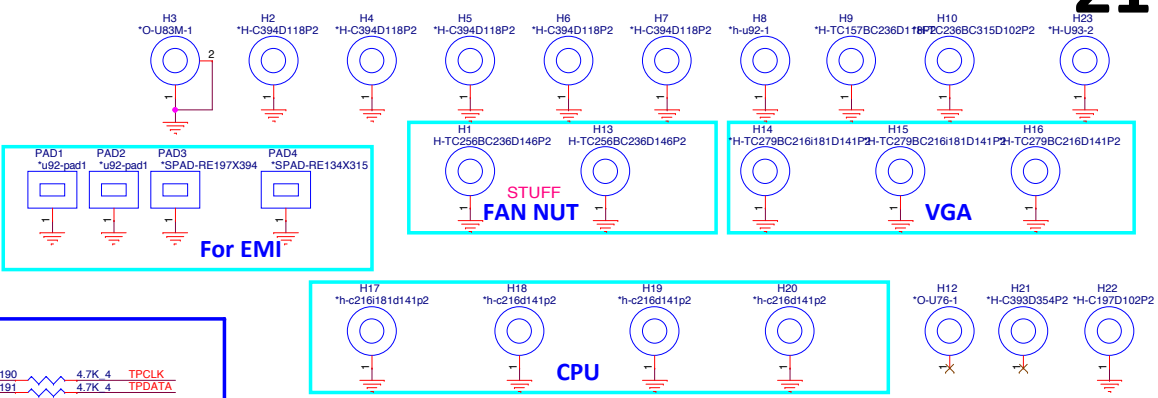

### SATA HDD Connector(Cable type)

#### Bypass CAP close conn

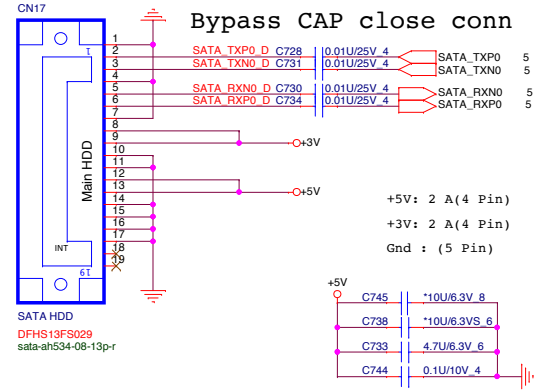

### Touch Pad

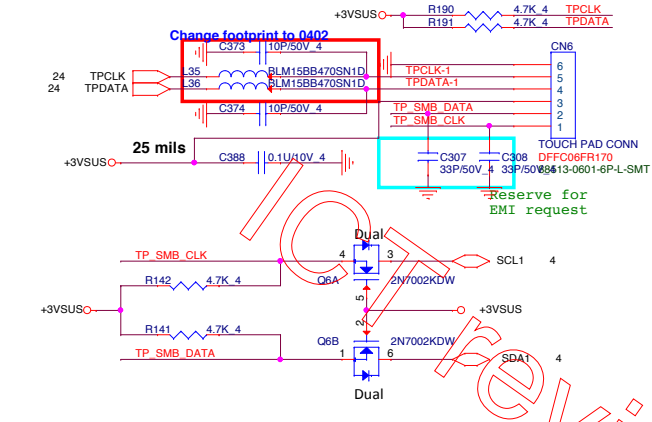

#### +VIN Cap

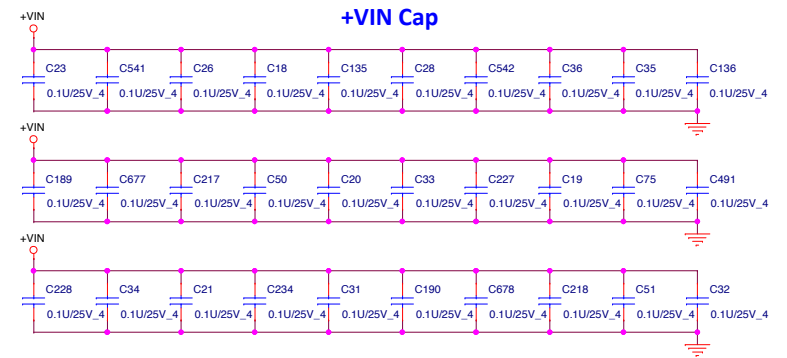

### SATA ODD CONNECTOR

#### 14" SATA ODD Bypass CAP close conn

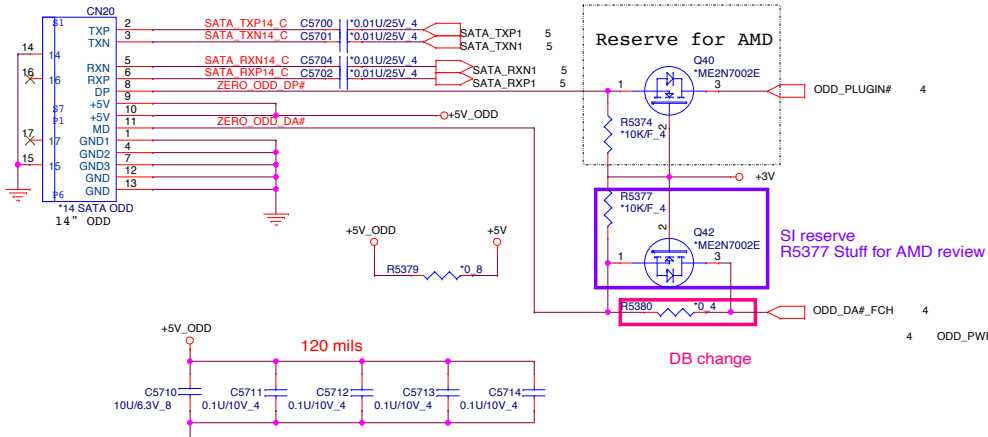

### 15" SATA ODD

#### New Type

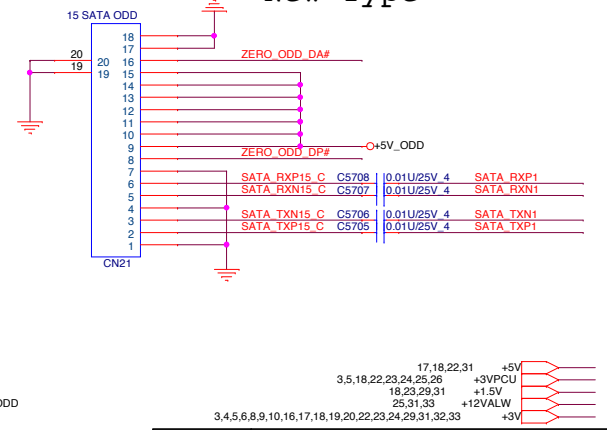

High : ODD power on  
 Low : ODD power down

DB change from dual-ch to one-ch

**PROJECT :U99**  
 Quanta Computer Inc.

Size Custom	Document Number <b>SATA HDD/ODD/MSATA CONN</b>	Rev 1A
Date: Monday, May 19, 2014	Sheet 21 of	33

# KEYBOARD Con.

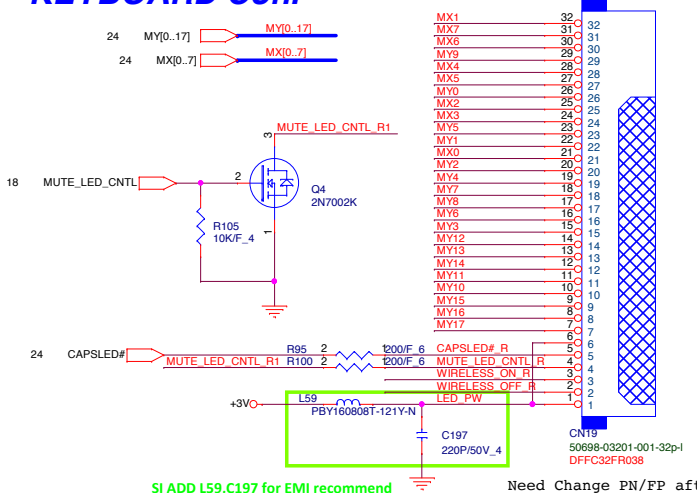

## KEYBOARD PULL-UP

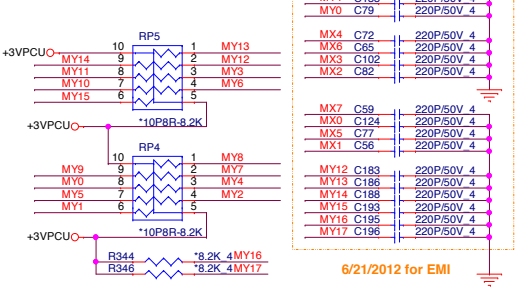

MY5	C106	220P/50V_4
MY6	C157	220P/50V_4
MY3	C179	220P/50V_4
MY7	C143	220P/50V_4
MY8	C153	220P/50V_4
MY9	C69	220P/50V_4
MY10	C192	220P/50V_4
MY11	C191	220P/50V_4
MY1	C119	220P/50V_4
MY2	C130	220P/50V_4
MY4	C133	220P/50V_4
MY0	C79	220P/50V_4
MY4	C72	220P/50V_4
MY6	C65	220P/50V_4
MX3	C102	220P/50V_4
MX2	C82	220P/50V_4
MX7	C59	220P/50V_4
MX0	C124	220P/50V_4
MX5	C77	220P/50V_4
MX1	C56	220P/50V_4
MY12	C183	220P/50V_4
MY13	C186	220P/50V_4
MY14	C188	220P/50V_4
MY15	C193	220P/50V_4
MY16	C195	220P/50V_4
MY17	C196	220P/50V_4

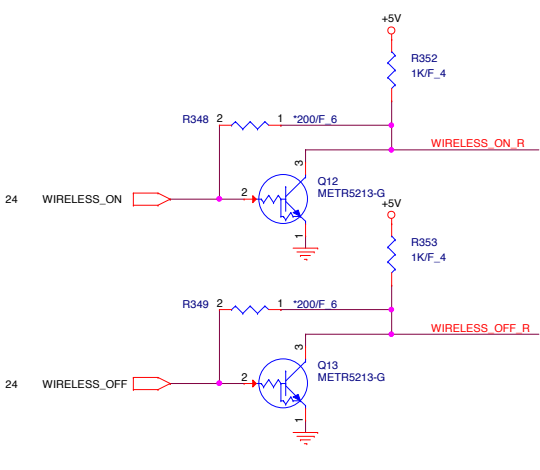

SI ADD L59,C197 for EMI recommend

## NM9 Type

## USB 2.0/3.0 Combo

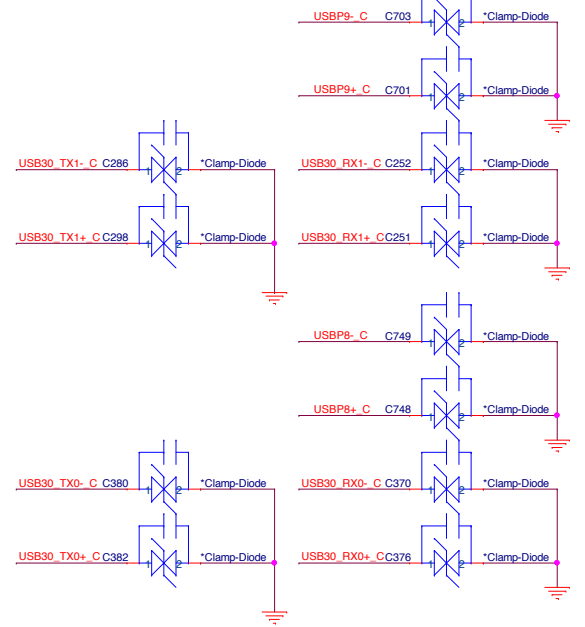

## SPS Type

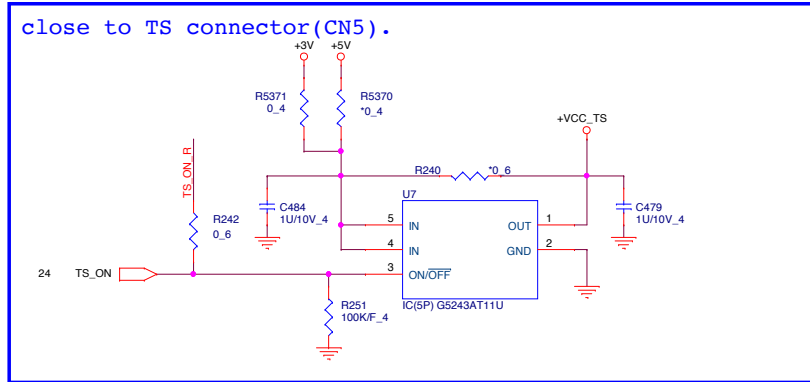
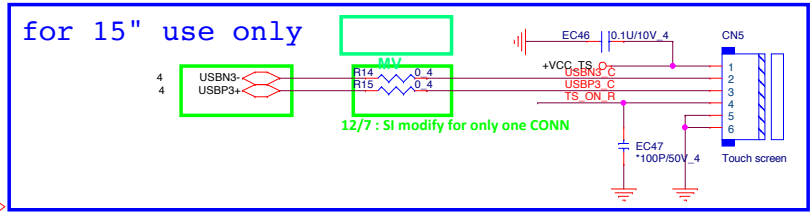
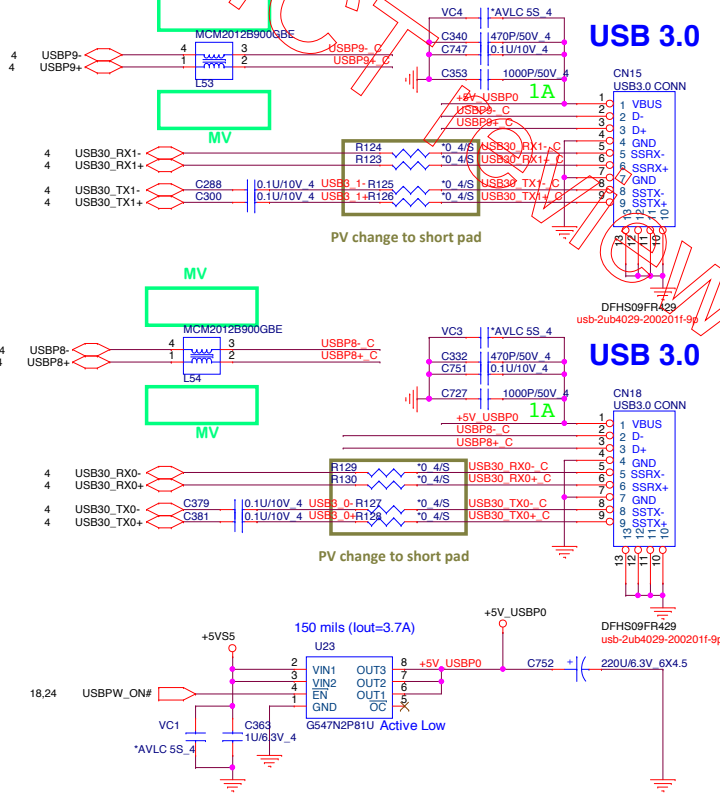

Mini Card  
WLAN/BT(Optional)

NM9 Type

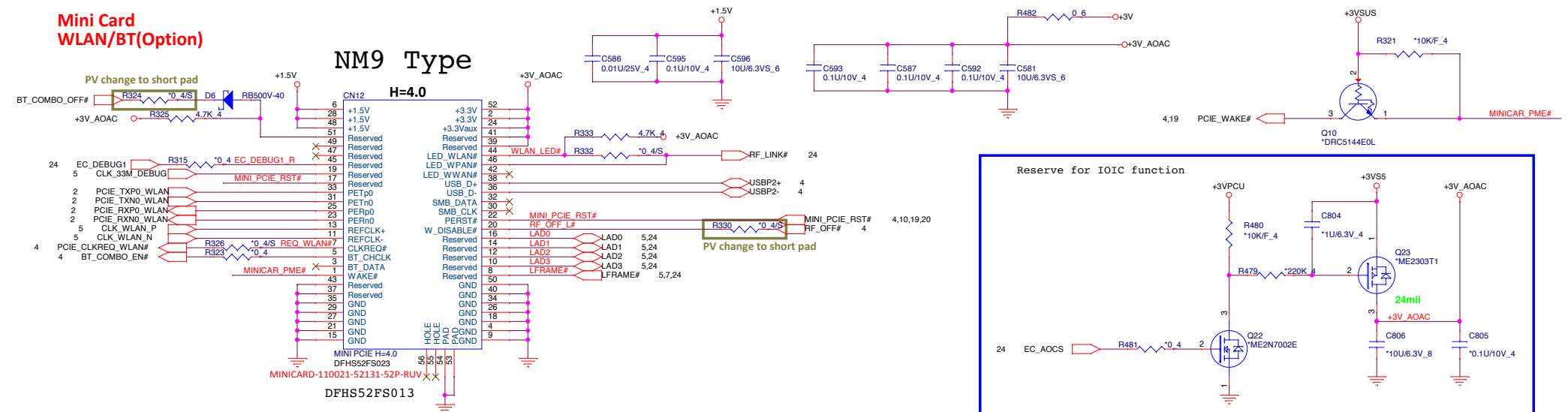

Accelerometer Sensor

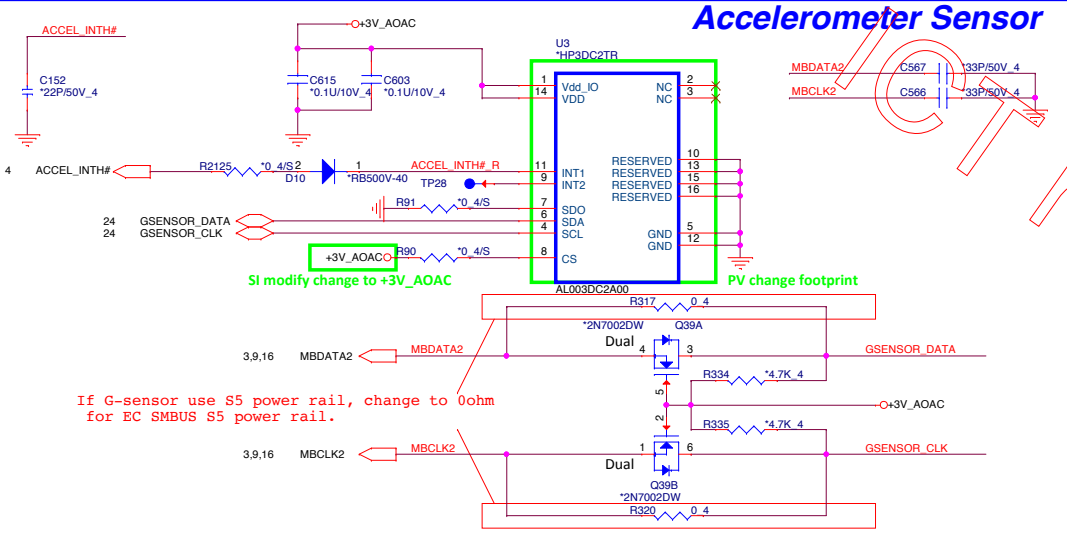

Green CLK Circuitry

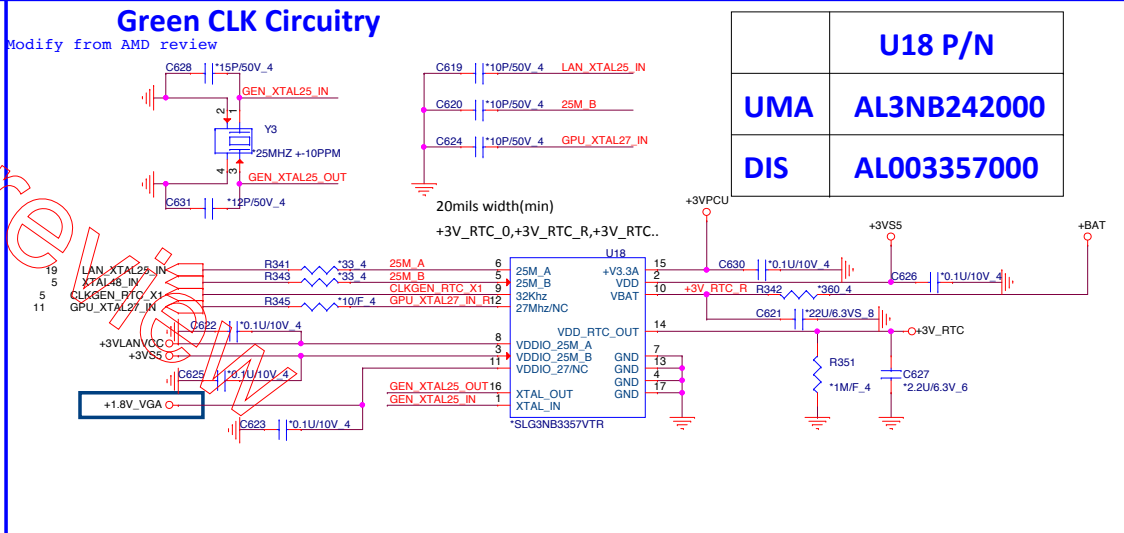

TPM (1.2)

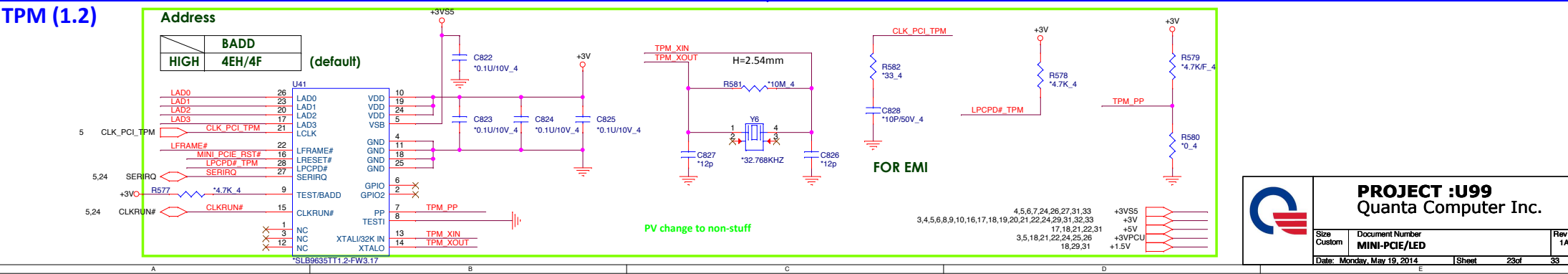

**PROJECT :U99**  
Quanta Computer Inc.

Size	Document Number	Rev
Custom	MINI-PCIE/LED	1A
Date: Monday, May 19, 2014	Sheet	23 of 33

3,4,5,6,8,9,10,16,17,18,19,20,21,22,23,29,31,32,33  
3,5,18,21,22,23,25,26

ITE pin 100, 104, 106 default can not pull up to +3VPCU it will cause chip into test mode

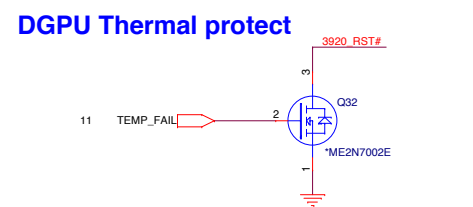
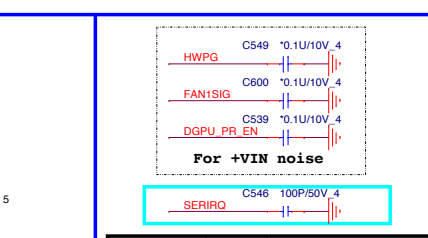
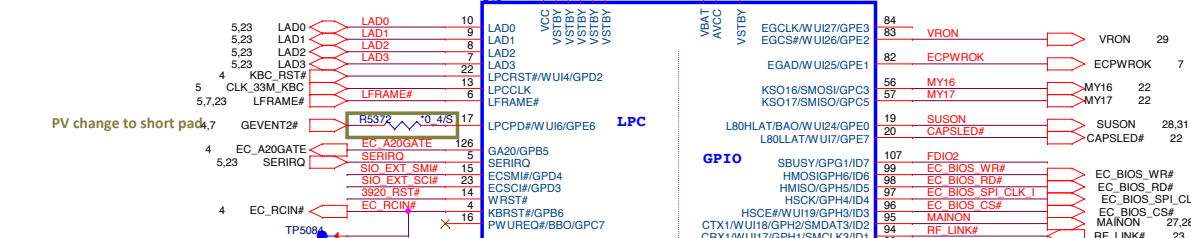
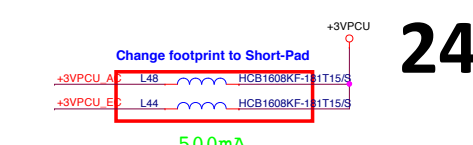
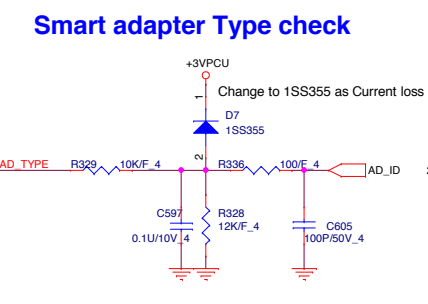
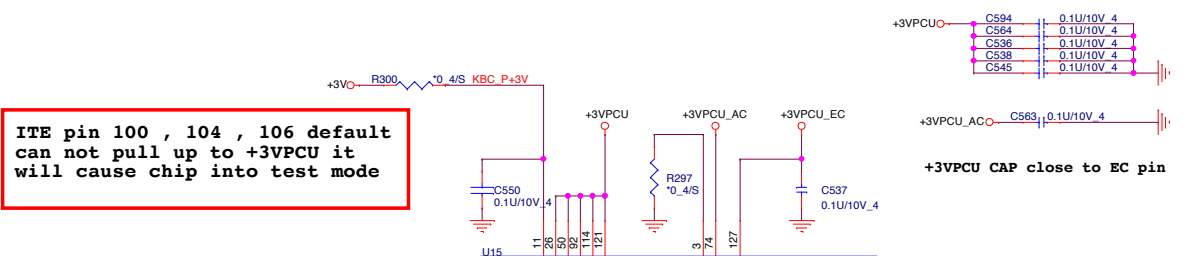

Table with 3 columns: Vender, Size, P/N. Rows include AIT (4M, AKE39ZN0800), EON (4M, AKE39ZN0Q03), WND (4M, AKE39FN0N01), and Socket (DFHS08FS023).

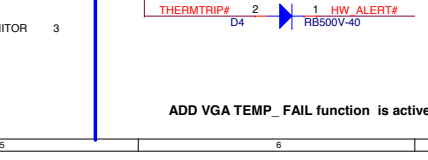
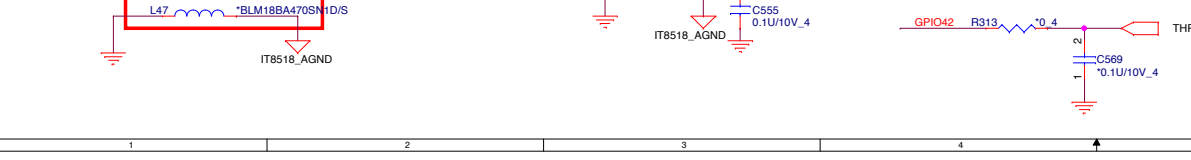
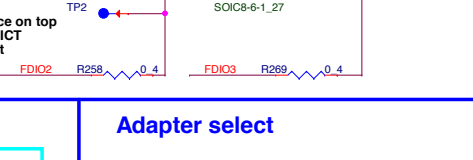
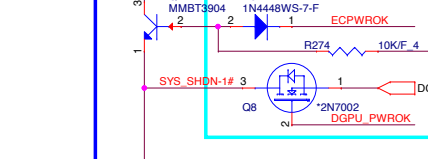
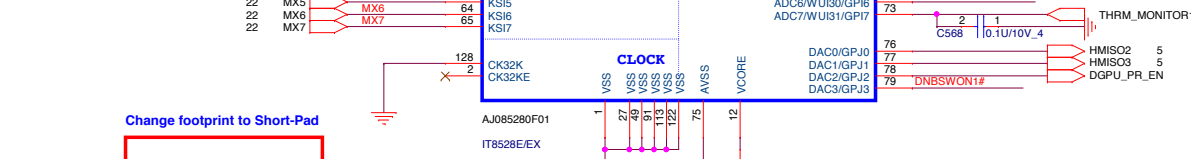
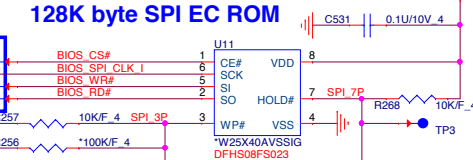
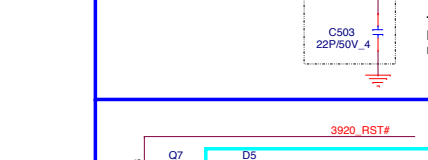
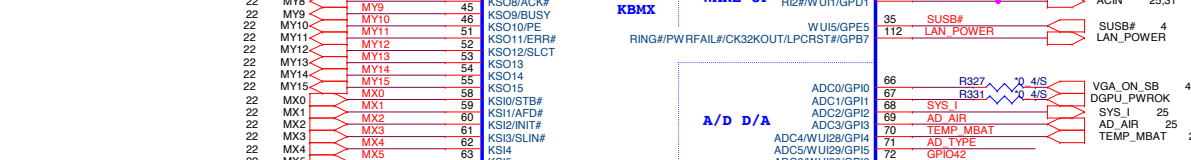
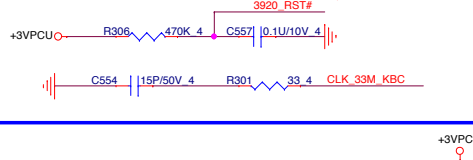
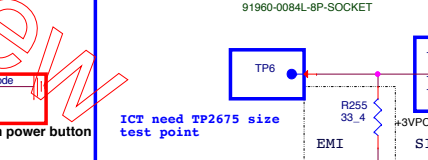
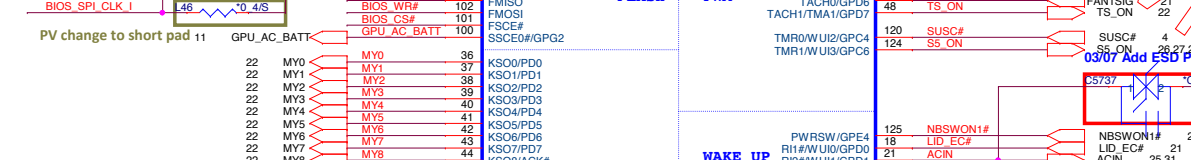
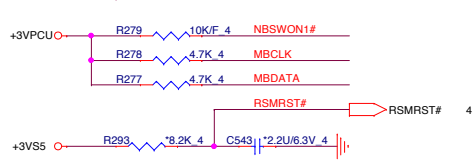
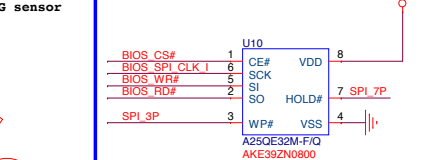
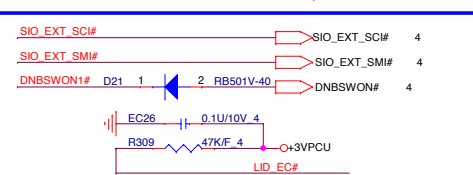
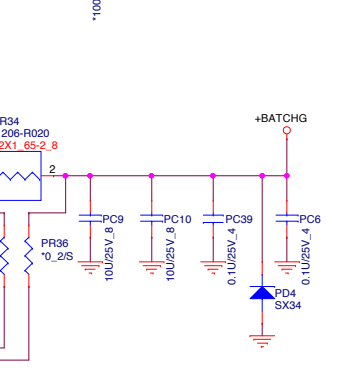
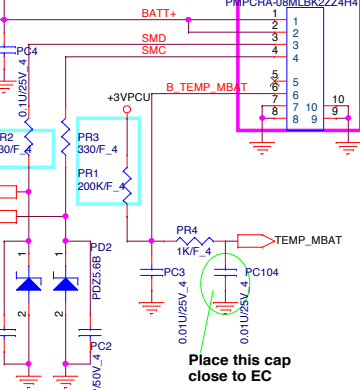
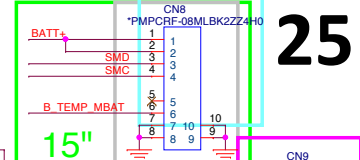
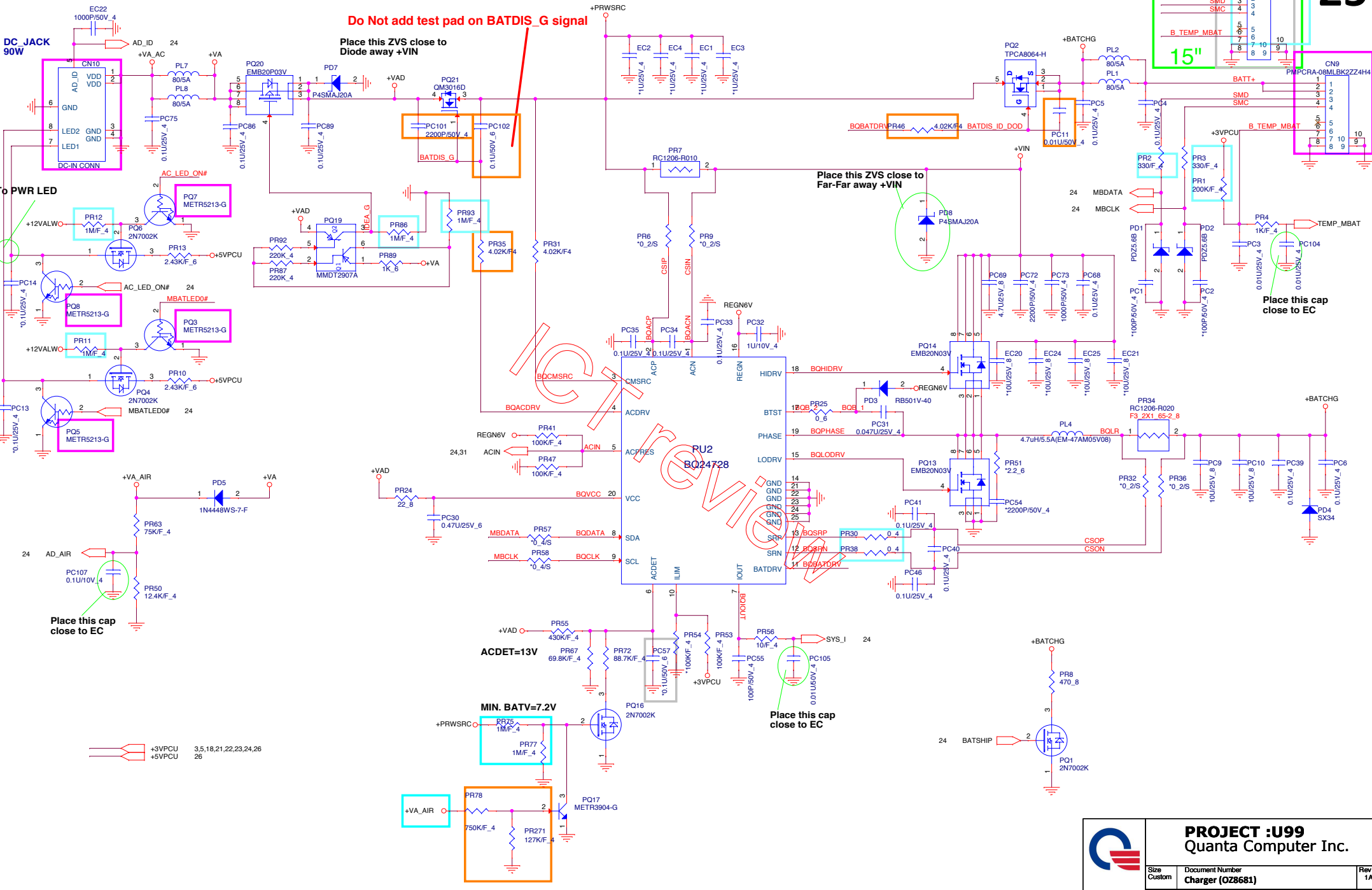

Table with 3 columns: Platform model, GPIO42, adapter. Rows include A6 25W CPU + DIS (High, 90W) and DIS/SG/UMA (Low, 65W).

PROJECT :U99 Quanta Computer Inc. Size Custom Document Number EC (IT8528E)/ROM Rev 1A Date: Monday, May 19, 2014 Sheet 24 of 33

ADD VGA TEMP\_FAIL function is active Hi



**+5 Volt +/- 5%**  
**Countinue current:4A**  
**Peak current:6A**  
**OCP minimum:7.5A**

**+3.3 Volt +/- 5%**  
**Countinue current:4A**  
**Peak current:6A**  
**OCP minimum:7.5A**

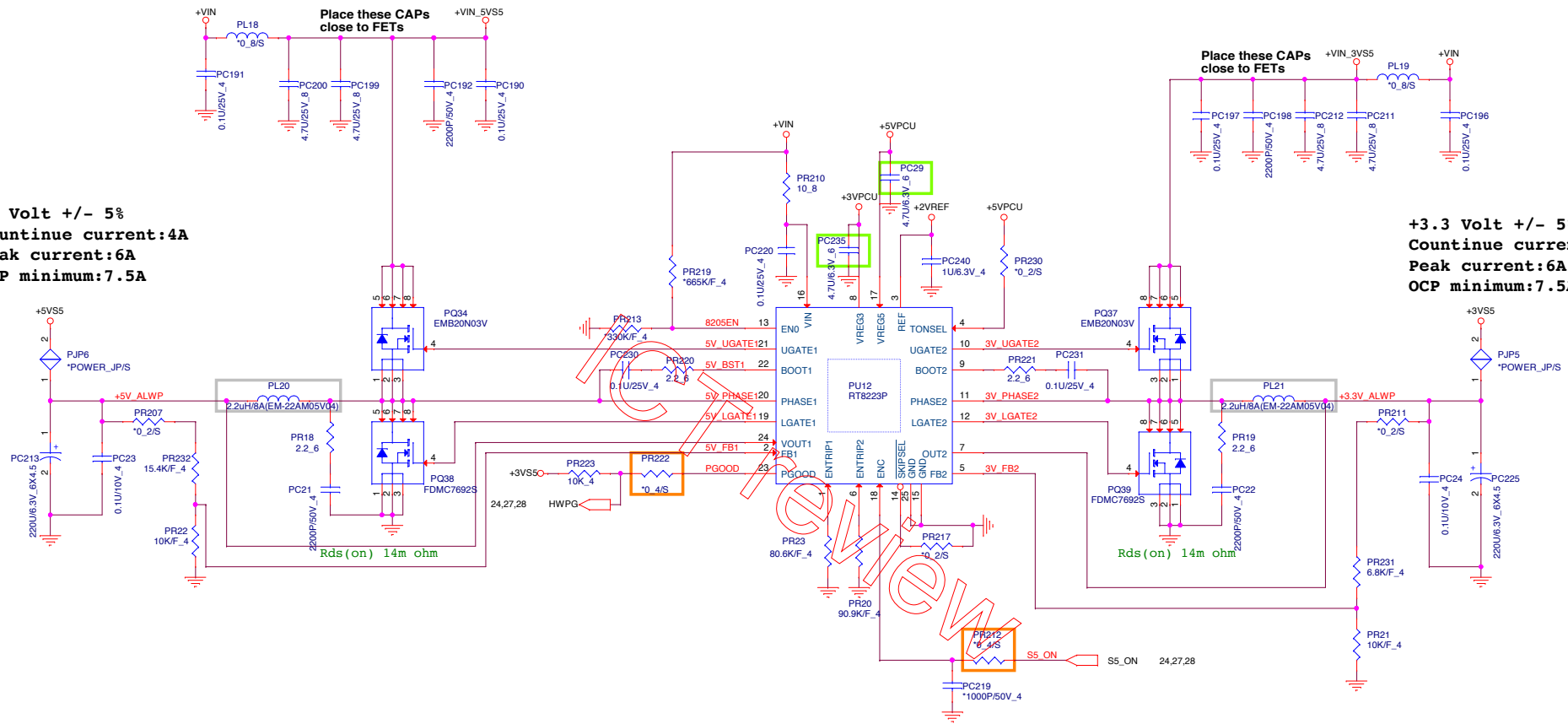

	<b>PROJECT :U99</b> Quanta Computer Inc.		
	Size Custom	Document Number <b>3/5VPCU(RT8223P)</b>	Rev 1A
	Date: Monday, May 19, 2014	Sheet 26 of 33	



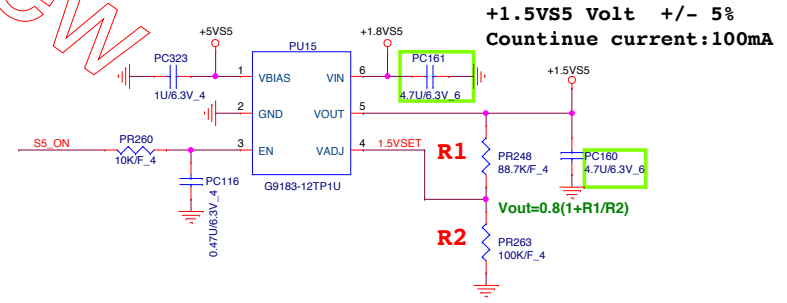
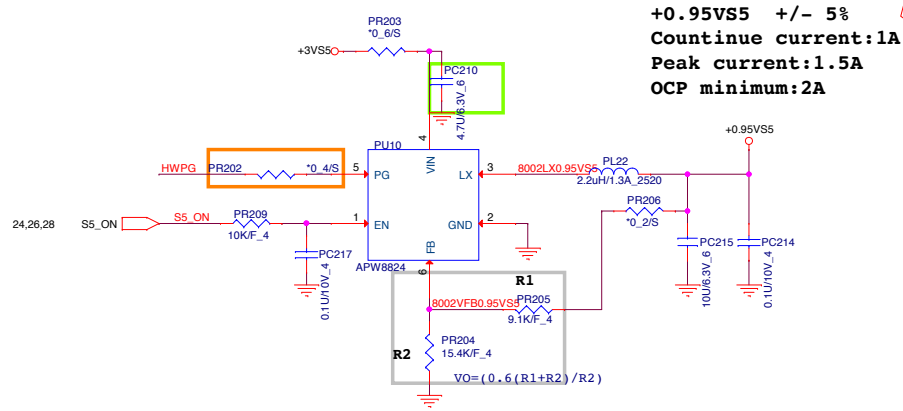
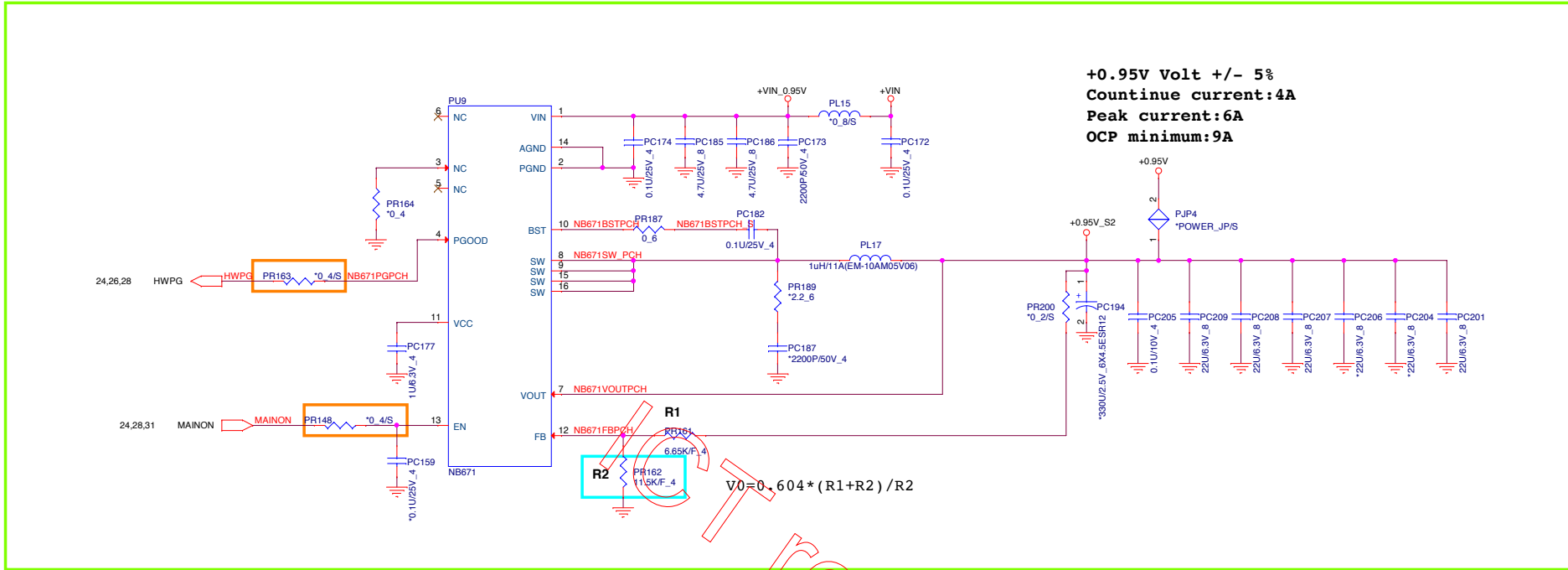

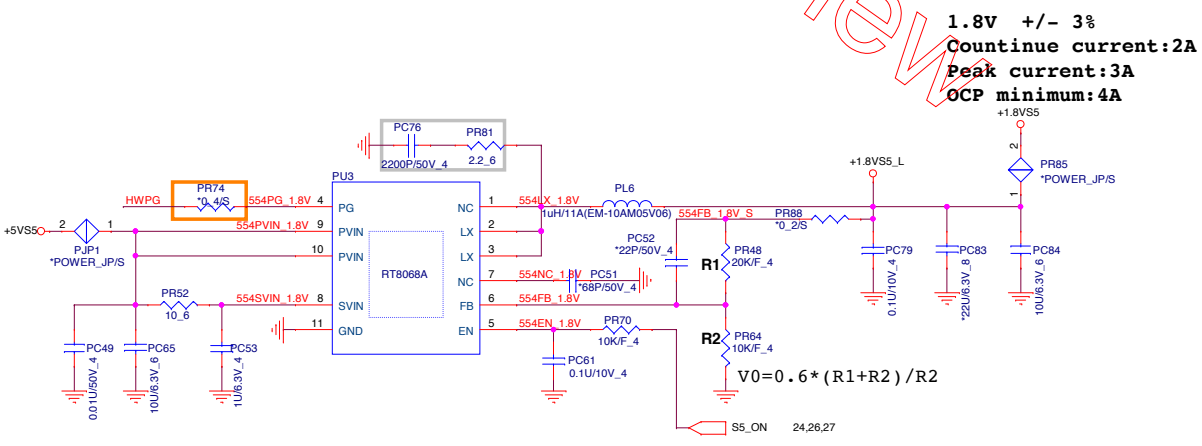
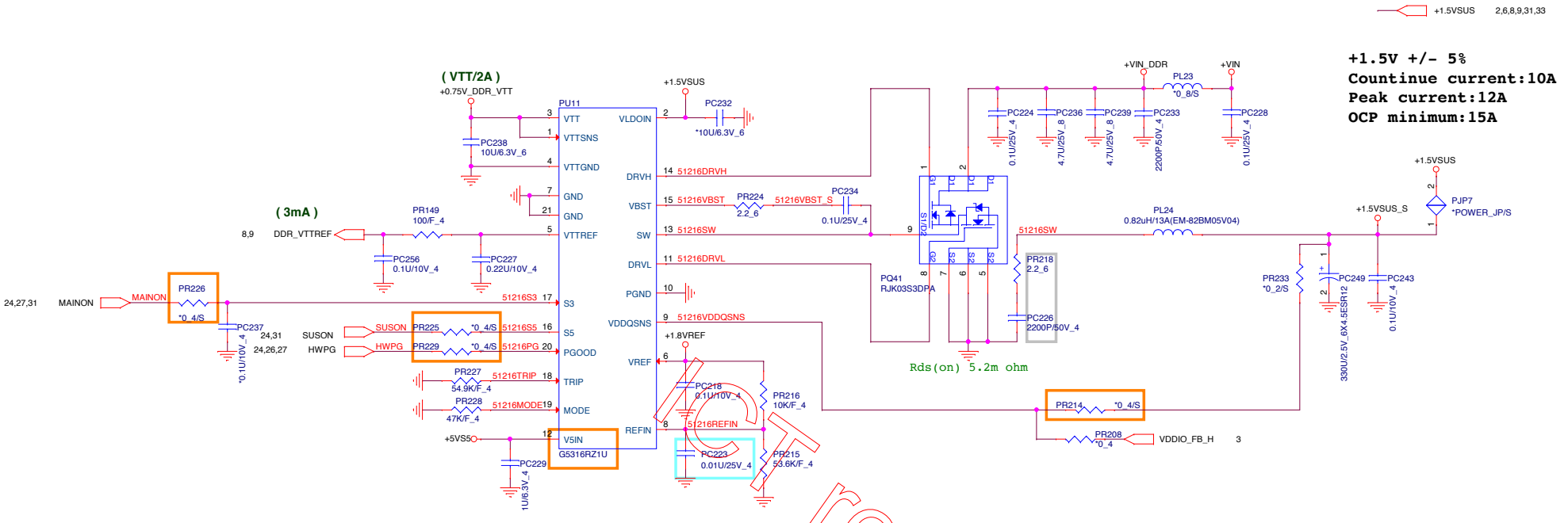

+1.5VSUS 2,6,8,9,31,33

**+1.5V +/- 5%**  
**Countinue current:10A**  
**Peak current:12A**  
**OCp minimum:15A**

review

 <b>PROJECT :U99</b> Quanta Computer Inc.		
Size Custom	Document Number <b>DDR3 (TP551216)</b>	Rev 1A
Date: Monday, May 19, 2014	Sheet 26	of 33

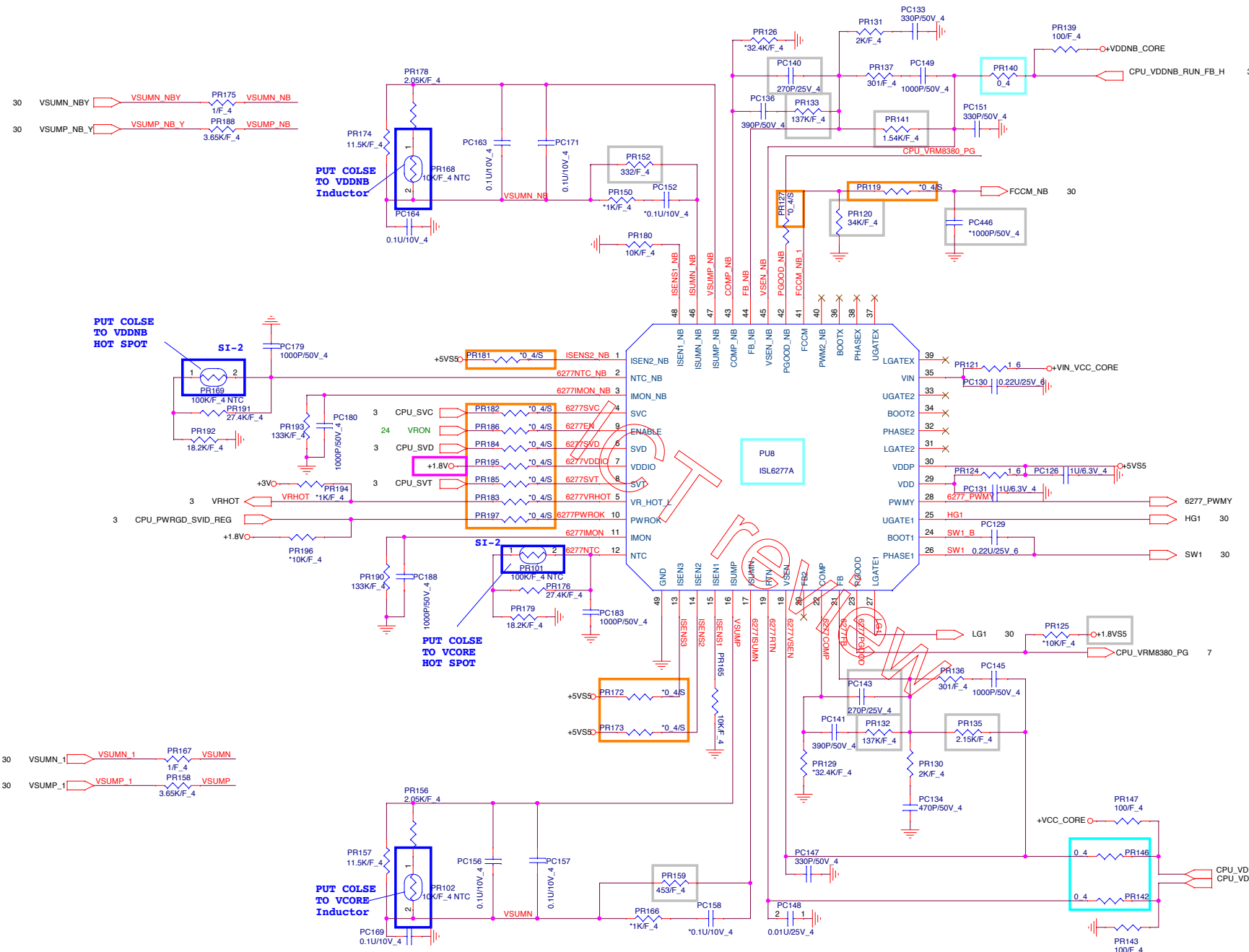

	<b>PROJECT :U99</b>	
	Quanta Computer Inc.	
	Size Custom	Document Number <b>ISL6277</b>
Date: Monday, May 19, 2014	Sheet 29	of 33

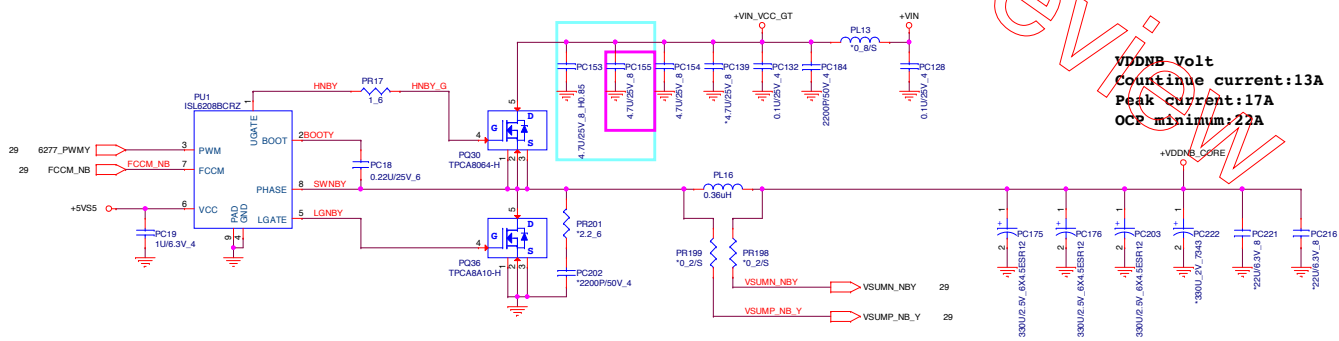
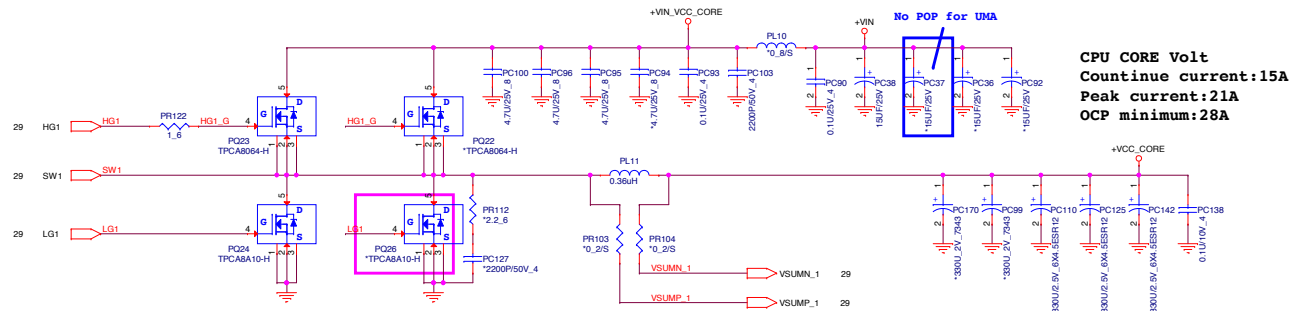

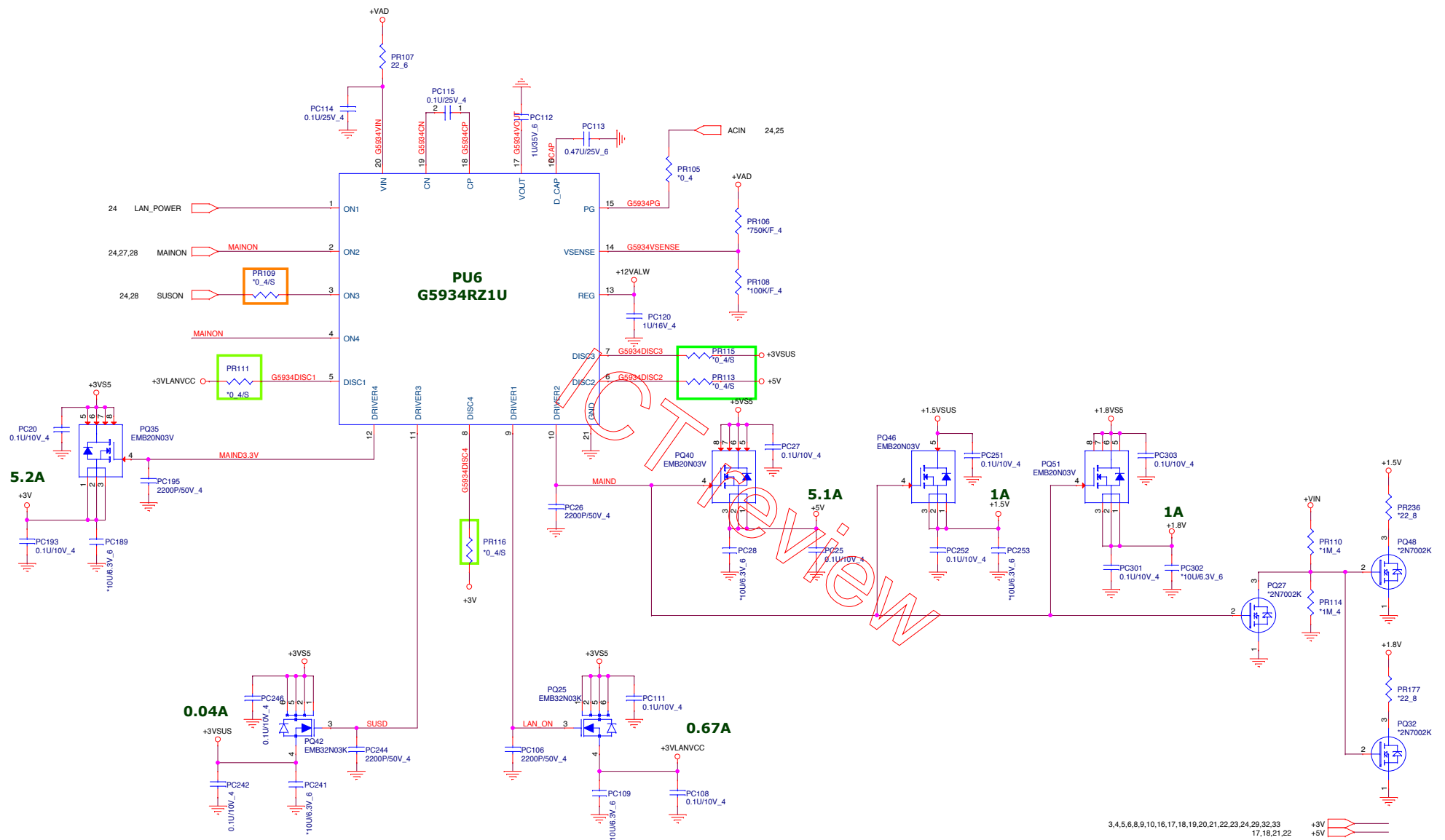

- 3,4,5,6,8,9,10,16,17,18,19,20,21,22,23,24,29,30,32,33 +3V
- 17,18,21,22 +5V
- 17,21,25,26,27,28,30,32,33 +VIN
- 4,5,6,7,23,24,26,27,33 +3VS5
- 18,22,26,27,28,29,30,32 +5VS5
- 25,33 +12VALW
- 19,23 +3VLANVCC
- 8,9,28 +0.75V\_DDR\_VTT

**PROJECT :U99**  
**Quanta Computer Inc.**

Size Custom	Document Number <b>Dis-charge IC (SLG55448V)</b>	Rev 1A
Date: Monday, May 19, 2014		

# VGA Core

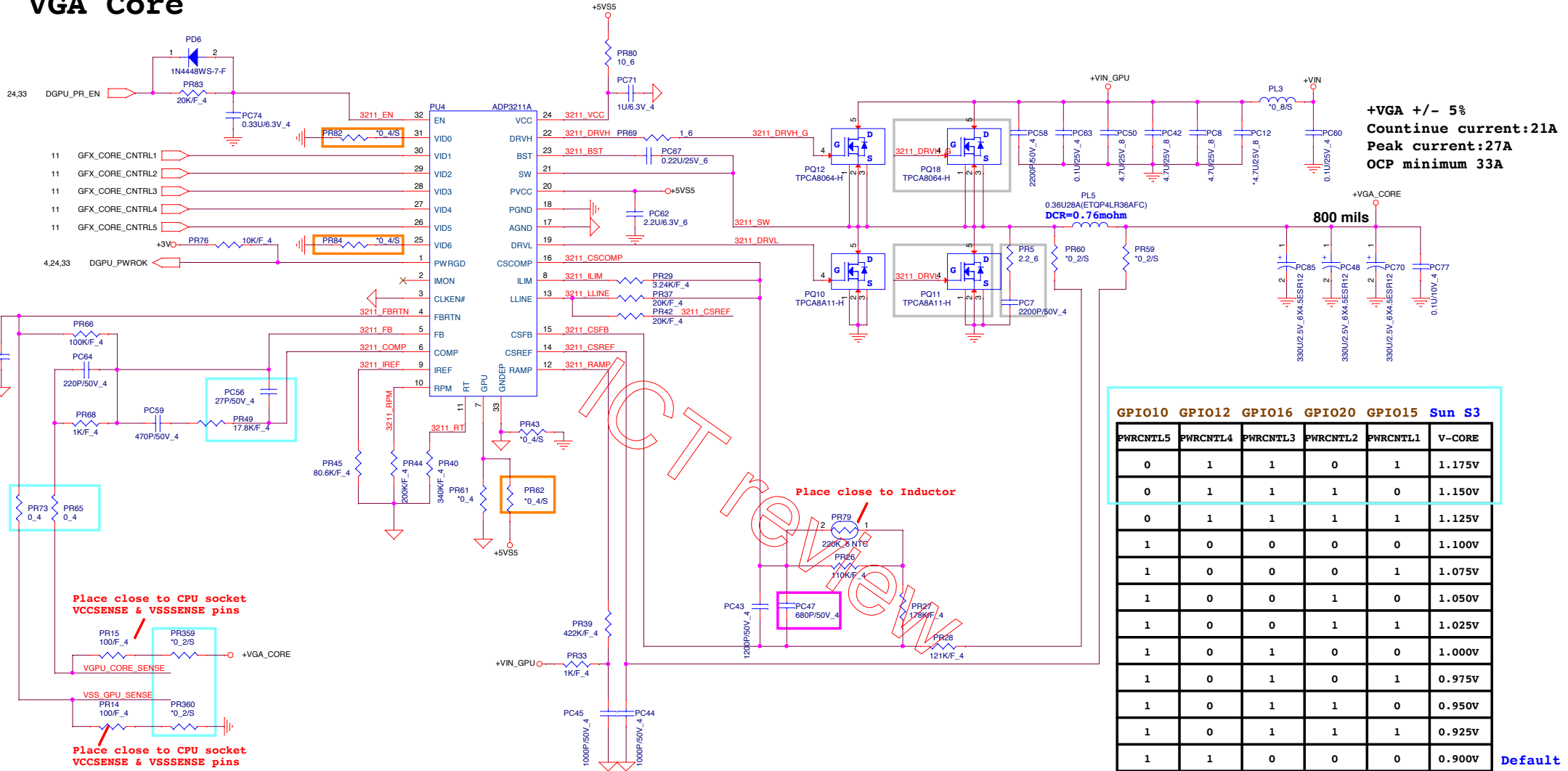

GPIO10	GPIO12	GPIO16	GPIO20	GPIO15	Sun S3	V-CORE
PWRCNTL5	PWRCNTL4	PWRCNTL3	PWRCNTL2	PWRCNTL1		1.175V
0	1	1	0	1		1.150V
0	1	1	1	0		1.125V
1	0	0	0	0		1.100V
1	0	0	0	1		1.075V
1	0	0	1	0		1.050V
1	0	0	1	1		1.025V
1	0	1	0	0		1.000V
1	0	1	0	1		0.975V
1	0	1	1	0		0.950V
1	0	1	1	1		0.925V
1	1	0	0	0		0.900V
1	1	0	0	1		0.875V
1	1	0	1	0		0.850V
1	1	0	1	1		0.825V
1	1	1	0	0		0.800V
1	1	1	0	1		0.775V

Default

**PROJECT :U99**  
Quanta Computer Inc.

Size Custom	Document Number +VGA CORE NCP3218G)	Rev 1A
Date: Monday, May 19, 2014	Sheet 32 of 33	



**+0.95V +/- 3%**  
**Continue current:2A**  
**Peak current:3A**  
**OCP minimum:4A**

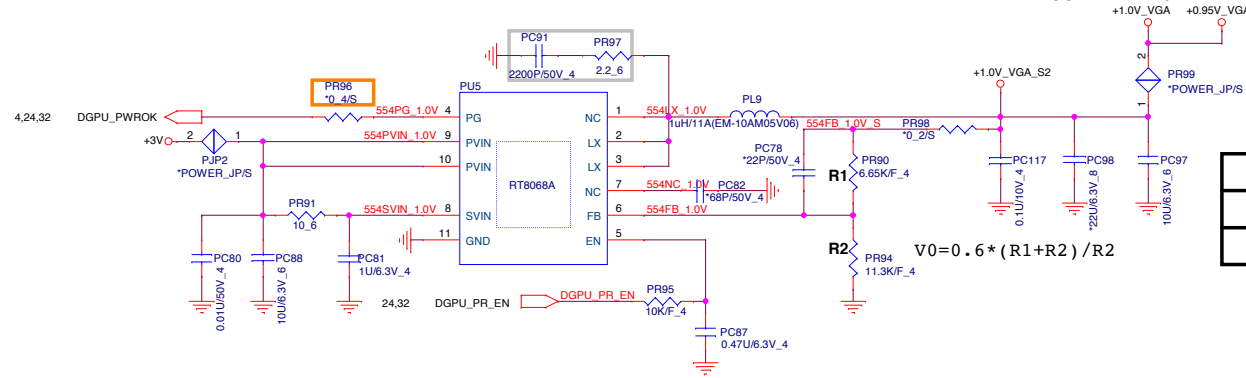

R2 Value	P/N	1.0V_VGA
10K	CS31002FB26	1.0V
11.3K	CS31132FB07	0.95V

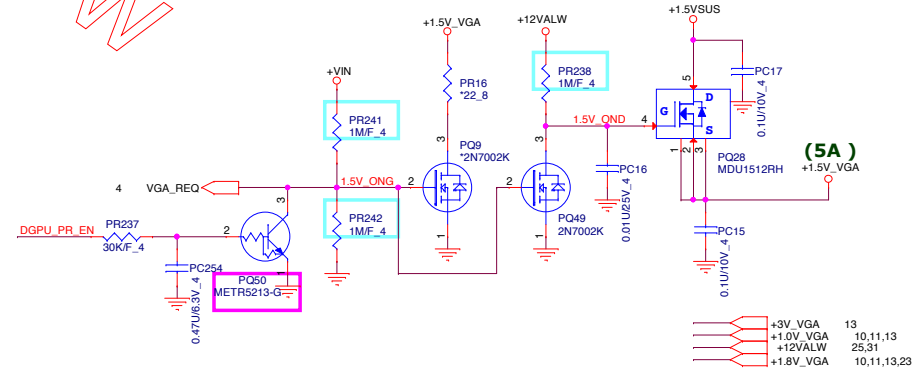
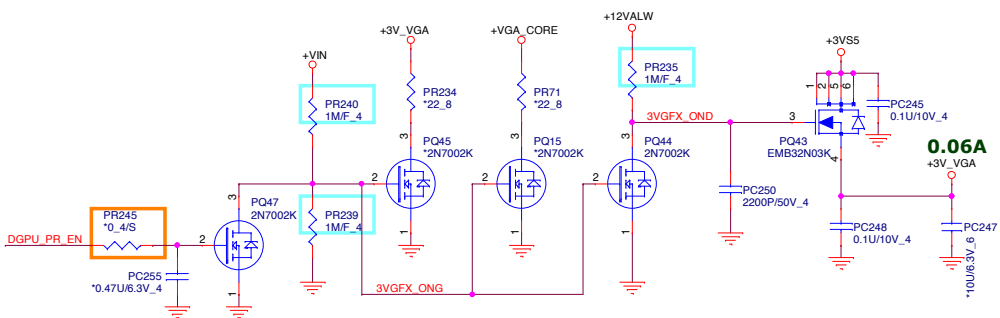
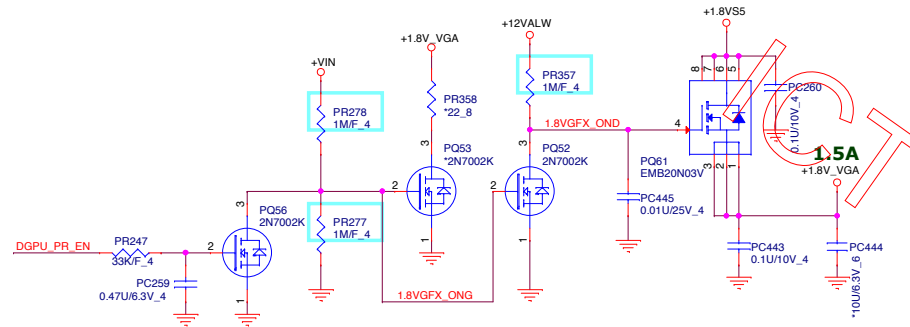

- +3V\_VGA 13
- +1.0V\_VGA 10,11,13
- +12VALW 25,31
- +1.8V\_VGA 10,11,13,23

DRAFT review

**PROJECT :U99**  
**Quanta Computer Inc.**

Size Custom	Document Number +VGA POWER	Rev 1A
Date: Monday, May 19, 2014		Sheet 33 of 33