

DIGITAL-LOGIC

smart embedded computers

TECHNICAL USER'S MANUAL FOR:

MICROSPACE[®]

PC/104

MSM586SEN/SEV (optional SN/SV)

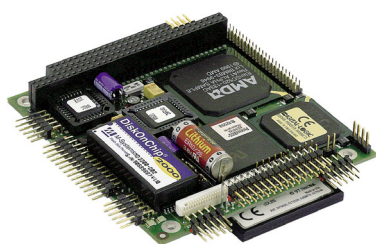

Nordstrasse 11/F

CH- 4542 Luterbach

Tel.: ++41 (0)32 681 58 00

Fax: ++41 (0)32 681 58 01

Email: support@digitallogic.com

Homepage: <http://www.digitallogic.com>

COPYRIGHT © 1999- 2001 BY DIGITAL-LOGIC AG

No part of this document may be reproduced, transmitted, transcribed, stored in a retrieval system, in any form or by any means, electronic, mechanical, optical, manual, or otherwise, without the prior written permission of DIGITAL-LOGIC AG.

The software described herein, together with this document, are furnished under a license agreement and may be used or copied only in accordance with the terms of that agreement.

ATTENTION:

All information in this manual and about the product are subject to change without prior notice.

REVISION HISTORY:

Prod.-Serialnumber: From: To:	Product Version	BIOS Version	Doc. Version	Date/Vis:	Modification: Remarks, News, Attention:
150xxx10000 150xxx1yyyy	V1.1	None	0.01	05.2000 FK	Initial version, Development
	V2.1	V1.20	V1.2	06.2001 STP	Serial product
	V2.1	V1.21	V1.3	08.2001 STP	Remote, COM's, jumper, memory map, etc
	V2.1	V1.21	V1.4	09.2001 STP	Thermopicture, etc
	V2.2	V1.23	V1.4	10.2001 KUF	Current, Boottime, BAT-Lifetime
	V2.3	V1.23	V1.4A	06.2002 KUF	COMx Pin10 new to VCC

Product Registration:

Please register your product at:

<http://www.digitallogic.com> -> SUPPORT -> Mailservice

After registration, you will receive driver & software updates, errata information, customer information and news from DIGITAL-LOGIC AG products automatically.

Table of Contents

1 Preface	6
1.1 How to use this Manual	6
1.2 Trademarks	6
1.3 Disclaimer	6
1.4 Who should use this Product.....	6
1.5 Recycling Information.....	7
1.6 Technical Support.....	7
1.7 Limited Warranty	7
2 Overview	8
2.1 Standard Features.....	8
2.2 Unique Features	8
2.3 MSM586SEN/SEV block diagram	9
2.4 Specifications	10
2.5 BIOS History	13
2.6 This product is "YEAR 2000 CAPABLE" 	13
2.7 Mechanical Dimensions	14
Board version V2.1/2.2	14
2.7.2 Board version V2.1/2.2	15
2.8 Incompatibilities to a standard PC/AT.....	16
2.9 Related application notes.....	16
2.10 Ordering codes.....	16
2.11 Thermoscan	17
2.12 High frequency radiation (to meet EN55022).....	18
3 PC/104 Bus Signals	19
3.1 Bus levels	23
4 Detailed System Description	24
4.1 Power Requirements	24
4.2 CPU, Boards and RAMs.....	26
4.2.1 CPUs of this MICROSPACE Product	26
4.2.2 Numeric Coprocessor	26
4.2.3 DRAM Memory	26
4.3 Interface	27
4.3.1 Keyboard AT compatible and PS/2 Mouse.....	27
4.3.2 Line Printer Port LPT1	27
4.3.3 Serial Ports COM1-COM4	27
4.3.4 Floppy Disk Interface	28
4.3.5 Speaker interface.....	29
4.4 Controllers	29
4.4.1 Interrupt Controllers	29
4.5 Timers and Counters	29
4.5.1 Programmable Timers	29
4.5.2 Internal Battery backed clock (RTC).....	30
4.5.3 External Battery assembling:	30
4.5.4 Watchdog.....	31
4.6 Boottime.....	32
5 BIOS	33
5.1 ROM-BIOS sockets	33
5.2 Standard BIOS ROM.....	33
5.3 EEPROM Memory for Setup	33
5.3.1 BIOS CMOS Setup	34
5.4 CMOS RAM Map.....	34

5.5	EEPROM saved CMOS setup	40
5.6	CORE - BIOS download function	41
5.6.1	CORE BIOS download	41
5.6.2	VGA BIOS download function	42
5.7	Memory	43
5.7.1	System Memory Map	43
5.7.2	System I/O map	43
5.8	BIOS Data Area Definitions	58
5.8.1	Compatibility Service Table	64
6	VGA, LCD	65
6.1	VGA / LCD controller 69000	65
6.2	VGA / LCD BIOS for 69000	65
6.3	Display modes supported	66
6.4	VGA/LCD BIOS support	67
6.5	Memory 69000 CRT/TFT panels	68
6.6	Memory 69000 color STN-DD panels	69
6.7	Memory 69000 Mono STN-DD panels	70
7	Description of the connectors	71
8	Jumper locations on the board	84
8.1	Jumpers locations on the MSM586SEN/SEV V2.1/2.2	85
9	LED criterions:	88
10	Cable interface	89
10.1	The harddisk cable 44pin	89
10.2	The COM 1/2/3/4 serial interface cable	90
10.3	The printer interface cable (P1)	91
10.4	The Micro Floppy interface cable	92
11	Remote Function	93
11.1	Remote Features	93
11.1.1	The Remote Server REMHOST.EXE	93
11.1.2	Remote enabler	94
11.1.3	Cable Definition	94
11.1.4	Restrictions	95
12	Software	95
13	100/10 Ethernet LAN	96
13.1	Intel 82559ER Ethernet chip	96
13.1.1	Installation example for MSDOS Novell 4.11	96
13.1.2	Driver installation WINDOWS 95	97
13.1.3	Driver installation WINDOWS 98SE	97
13.1.4	Driver installation WINDOWS NT	97
13.1.5	Driver installation WINDOWS 2000	97
13.1.6	EEPROM update	97
13.2	Intel 82559 Ethernet chip	98
13.2.1	Installation example for MSDOS Novell 4.11	98
13.2.2	Driver installation WINDOWS 95	98
13.2.3	Driver installation WINDOWS 98SE	98
13.2.4	Driver installation WINDOWS NT	99
13.2.5	Driver installation WINDOWS 2000	99
13.2.6	EEPROM update	99
14	Installing the flashdisk DOC2000	100
14.1	Enabling and formatting of the DiskOnChip-module	100
14.2	Compact Flash (CF)	100
15	Special Peripherals, Configuration	101

15.1 The special function interface for MICROSPACE	101
16 Building a system	106
16.1 Starting up the system.....	106
17 Diagnostics.....	107
17.1 Failures and hints	107
17.1.1 Other, so far not identified problems	107
17.2 POST-CODE Description	108
17.2.1 Boot Loader	108
17.2.2 Error Beep codes	108
17.2.3 System BIOS in Shadow RAM.....	108
17.2.4 Error Beep codes	109
18 INDEX.....	110

1 **PREFACE**

This manual is for integrators and programmers of systems based on the MICROSPACE card family. It contains information on hardware requirements, interconnections, and details of how to program the system. The specifications given in this manual were correct at the time of printing; advances mean that some may have changed in the meantime. If errors are found, please notify DIGITAL-LOGIC AG at the address shown on the title page of this document, and we will correct them as soon as possible.

1.1 *How to use this Manual*

This manual is written for the original equipment manufacturer (OEM) who plans to build computer systems based on the single board MICROSPACE-PC. It provides instructions for installing and configuring the MSM586SEV board, and describes the system and setup requirements.

1.2 *Trademarks*

Chips & Technologies SuperState R
MICROSPACE, MicroModule DIGITAL-LOGIC AG
DOS Vx.y, Windows Microsoft Inc.
PC-AT, PC-XT IBM
NetWare Novell Corporation
Ethernet Xerox Corporation
DR-DOS, PALMDOS Digital Research Inc. / Novell Inc.
ROM-DOS Datalight Inc.

1.3 *Disclaimer*

DIGITAL-LOGIC AG makes no representations or warranties with respect to the contents of this manual and specifically disclaims any implied warranty of merchantability or fitness for any particular purpose. DIGITAL-LOGIC AG shall under no circumstances be liable for incidental or consequential damages or related expenses resulting from the use of this product, even if it has been notified of the possibility of such damage. DIGITAL-LOGIC AG reserves the right to revise this publication from time to time without obligation to notify any person of such revisions. If errors are found, please contact DIGITAL-LOGIC AG at the address listed on the title page of this document.

1.4 *Who should use this Product*

- Electronic engineers with know-how in PC-technology.
- Without electronic know-how we expect you to have questions. This manual assumes, that you have a general knowledge of PC-electronics.
- Because of the complexity and the variability of PC-technology, we can't give any warranty that the product will work in any particular situation or combination. Our technical support will help you to may get a solution.
- Pay attention to the electrostatic discharges. Use a CMOS protected workplace.
- Power supply OFF when you are working on the board or connecting any cables or devices.

**This is a high technology product.
You need know-how in electronics and PC-technology to
install the system !**

1.5 Recycling Information

Hardware:

- **Print:** epoxy with glass fiber
wires are of tin-plated copper
- **Components:** ceramics and alloys of gold, silver
check your local electronic recycling

Software:

- **no problems:** re-use the diskette after formatting

1.6 Technical Support

1. **Contact your local DIGITAL-LOGIC Technical Support in your country first !**
2. Use the Internet Support Center at <http://www.digitallogic.com> -> Support
3. Send a FAX or an E-mail to DIGITAL-LOGIC AG with a description of your problem.

DIGITAL-LOGIC AG
smartModule DesignIn Center
Nordstr. 11/F
CH-4542 Luterbach (SWITZERLAND)
Fax: ++41 32 681 58 01
E-Mail: support@digitallogic.com
Internet: www.digitallogic.com

- Support requests will only be accepted with detailed information of the product (BIOS-, Board- Version) !

1.7 Limited Warranty

DIGITAL-LOGIC AG warrants the hardware and software products it manufactures and produces to be free from defects in materials and workmanship for one year following the date of shipment from DIGITAL-LOGIC AG, Switzerland. This warranty is limited to the original purchaser of product and is not transferable. During the one year warranty period, DIGITAL-LOGIC AG will repair or replace, at its discretion, any defective product or part at no additional charge, provided that the product is returned, shipping prepaid, to DIGITAL-LOGIC AG. All replaced parts and products become property of DIGITAL-LOGIC AG.

Before returning any product for repair, customers are required to contact the company.

This limited warranty does not extend to any product which has been damaged as a result of accident, misuse, abuse (such as use of incorrect input voltages, wrong cabling, wrong polarity, improper or insufficient ventilation, failure to follow the operating instructions that are provided by DIGITAL-LOGIC AG or other contingencies beyond the control of DIGITAL-LOGIC AG), wrong connection, wrong information or as a result of service or modification by anyone other than DIGITAL-LOGIC AG. Neither, if the user has not enough knowledge of these technologies or has not consulted the product manual or the technical support of DIGITAL-LOGIC AG and therefore the product has been damaged.

Except, as expressly set forth above, no other warranties are expressed or implied, including, but not limited to, any implied warranty of merchantability and fitness for a particular purpose, and DIGITAL-LOGIC AG expressly disclaims all warranties not stated herein. Under no circumstances will DIGITAL-LOGIC AG be liable to the purchaser or any user for any damage, including any incidental or consequential damage, expenses, lost profits, lost savings, or other damages arising out of the use or inability to use the product.

2 OVERVIEW

2.1 Standard Features

The MICROSPACE PC/104 is a miniaturized modular device incorporating the major elements of a PC/AT compatible computer.

It includes standard PC/AT compatible elements, such as:

- Powerful ELAN520 133MHz
- BIOS ROM
- SODIMM 16 to 128 MBytes 70ns (32bit device, no ECC supported)
- Timers
- DMA
- Real-time clock with CMOS-RAM and battery buffer
- LPT1 parallel port
- COM1, COM2, COM3, COM4 serial port
- Speaker interface
- AT-keyboard interface or PS/2-keyboard interface
- PS/2 mouse interface
- Floppy disk interface
- AT-IDE harddisk interface
- VGA/LCD video interface
- PC/104 embedded BUS

2.2 Unique Features

The MICROSPACE includes all standard PC/AT functions plus unique DIGITAL-LOGIC AG enhancements, such as:

- Single 5 volt supply
- LAN Ethernet 82559ER
- DOC2000
- Compact card. typ 1
- Watchdog
- Power-fail
- EEPROM for setup and configuration
- Core- and VGA BIOS downloadable
- JTAG for debugging with CADUL KIT
- **(NO** Power management functions yet)
- UL approved parts

2.3 *MSM586SEN/SEV block diagram*

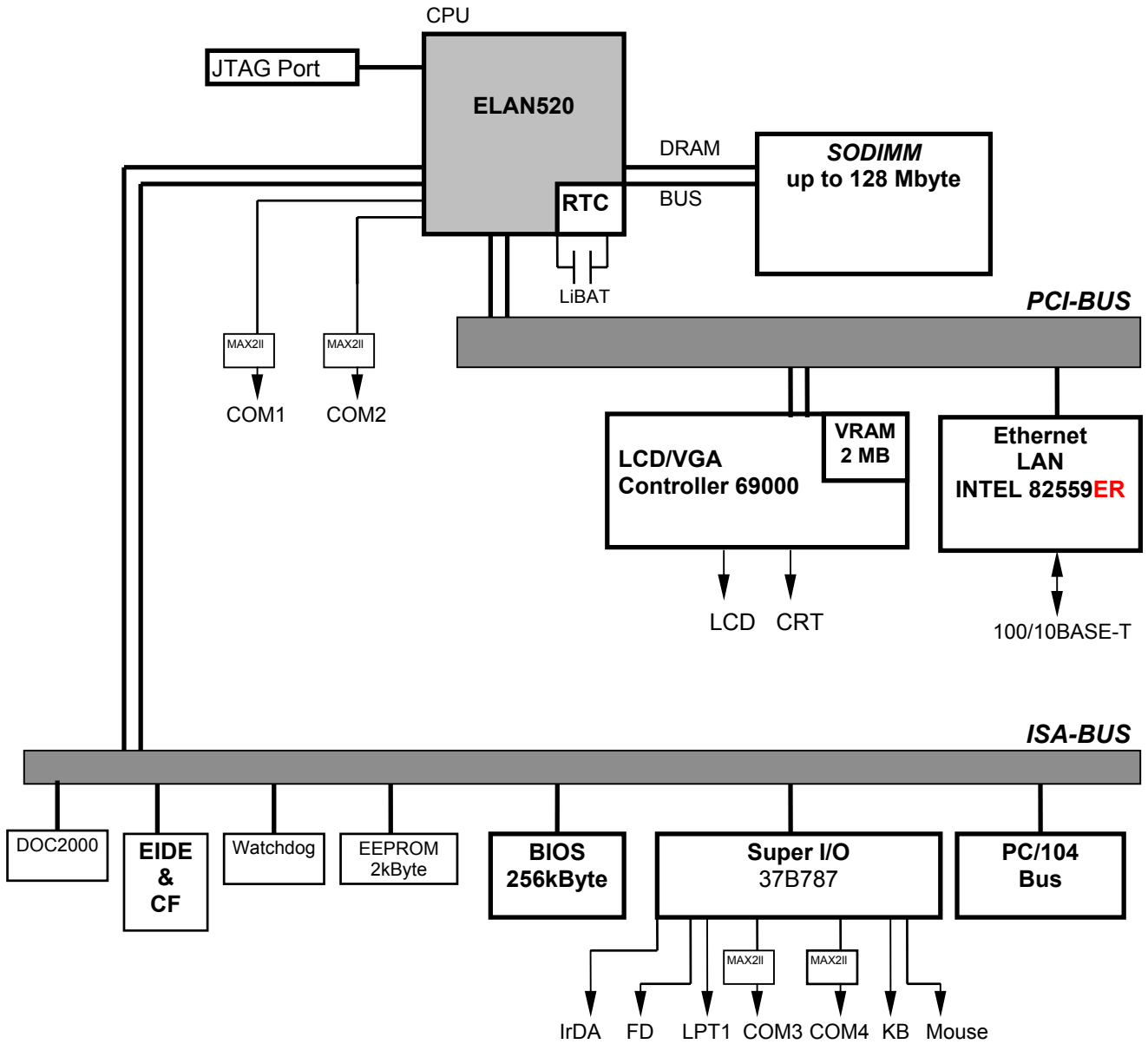

2.4 Specifications

CPU:

CPU :	ELAN520
CPU Core Supply:	Very low powered; core 2.5V, I/O 3.3V
Mode:	Real / Protected
Compatibility:	X86
Word Size:	32 Bits
Secondary Cache:	None
Physical Addressing:	32 lines
Virtual Addressing:	16 Gbytes
Clock Rates:	133 MHz

Math. Coprocessor:

Integrated in the ELAN520™

Power Management:

Not available yet !

DMA:

8237A comp. 4 channels

Interrupts:

8259 comp. 8 + 7 levels
PC compatible, extern only 10 IRQ lines

Timers:

8254 comp. 3 programmable counter/timers

Memory:

DRAM SODIMM 144pin 32Bit-Module needed
up to 128MB SDRAM (32bit, no ECC supported)

Video:

Controller:	69000 from C&T
BUS:	32 Bit high speed 33 MHz PCI bus
Enhanced BIOS:	VGA / LCD BIOS
Memory:	VRAM onboard: 2MByte - 32 Bit
CRT-Monitor:	VGA, SVGA up to 1280 x 1024 pixels 256 colors
Flatpanel:	TFT 3.3V: 640 x 480 with 8/16/256 colors STN: 640 x 480 monochrome STN: 640 x 480 with 256 colors Plasma: up to 1280 x 1024 EL: 640 x 350 , 640 x 480, 768 x 1024 pixels
Controller Modes:	CRT only; Flatpanel only or simultaneous CRT and Flatpanel
Drivers:	WIN3.11, WIN95/98, NT4.0

Mass Storage:

FD: Floppy disk interface, for max. 1 floppy with 26pin connector
HD: E-IDE interface, AT-type, for max. 2 harddisks, 44pin connector, for 1.3, 1.8 and 2.5" harddisk with 44 pins IDE

Standard AT Interfaces:

Serial:	Name	FIFO	IRQs	Addr.	Standard	Option
	COM1	yes	IRQ4	3F8	RS232C	
	COM2	yes	IRQ3	2F8	RS232C	
	COM3	yes	IRQ4/ 5	3E8	RS232C	
	COM4	yes	IRQ3/ 7	2E8	RS232C	

(Baudrates: 50 - 115 kBaud programmable)

Parallel:	LPT1 printer interface mode: SPP(output), EPP (bidir.)
Keyboard:	AT or PS/2 –keyboard
Mouse:	PS/2
Speaker:	0.1 W output drive
RTC:	Integrated into ELAN520, RTC with CMOS-RAM 114Byte
Backup current:	<5 μ A
Battery:	3.6 Volt Lithium 410mAh internal connected, not chargeable. RTC voltage range +2.0V... 3.3V (battery voltage >2.6V... <3.9V)

Supervisory:

Watchdog:	1, 2, 4, 8, 16, 32seconds programmable, ELAN520 internal
-----------	--

BUS:

PC/104	IEEE-996 standard bus, buffered
Clock:	8.25 MHz (33MHz / 4), since V3.8

Peripheral Extension:

ISA	With PC/104 BUS
PCI	Internally used (LAN and VGA)

Power Supply:

Working:	5 Volts \pm 5%
Power Rise Time:	\geq 100 μ s (OV --> 4,75V)
Current:	MSM586SEV-133 / 128MB < 1.5 A, (see separate pdf- file with for information) and chapter 4.5.3.1
Suspended	Not available

Physical Characteristics:

Dimensions:	Length:	91 mm
	Depth:	96 mm
	Height:	25 mm
Weight:	170 gr	
PCB Thickness:	1.6 mm / 0.0625 inches nominal	
PCB Layer:	Multilayer	

Operating Environment:

Relative humidity:	5 - 90% non condensing	
Vibration:	5 to 2000 Hz	
Shock:	10 G	
Temperature CPU:	Operating:	Standard version: -25°C to +60°C Extended version: -40°C to +85°C
	Storage:	-65°C to +125 °C

EMI / EMC (IEC1131-2 refer MIL 461/462):

ESD Electro Static Discharge:	IEC 801-2, EN55101-2, VDE 0843/0847 Part 2 Metallic protection needed Separate Ground Layer included 15 kV single peak
REF Radiated Electromagnetic Field:	IEC 801-3, VDE 0843 Part 3, IEC770 6.2.9. Not tested
EFT Electric Fast Transient (Burst):	IEC 801-4, EN50082-1, VDE 0843 Part 4 250V - 4kV, 50 ohms, Ts=5ns Grade 2: 1KV Supply, 500 I/O, 5Khz
SIR Surge Immunity Requirements:	IEC 801-5, IEEE587, VDE 0843 Part 5 Supply: 2 kV, 6 pulse/minute I/O: 500 V, 2 pulse/minute FD, CRT: none
High-frequency Radiation:	EN55022

Compatibility:

Board:	Mechanically compatible to our MSMx86 Boards and to all other PC/104 boards
--------	---

Any information is subject to change without notice.

2.5 BIOS History

Version:	Date:	Status:	Modifications:
V1.00	Mai.2000	Development Test	Initial prototyp BIOS
V1.11	06.2001	Development Test	Initial standard BIOS
V1.20	06.2001	Beta	Standard BIOS for boardversions >2.0
V1.21	08.2001	Beta	DOC2000 support, IRQ15 enabled, FDD B off,
V1.22	09.2001	Released	IN10 disabled, LPT en/disable, date 1.1.2000 battery less
V1.23	10.2001	Released	INT10 in E- segment

2.6 This product is "YEAR 2000 CAPABLE"

This DIGITAL-LOGIC product is "YEAR 2000 CAPABLE". This means, that upon installation, it accurately stores, displays, processes, provides and/or receives date data from, into, and between 1999 and 2000, and the 20. and 21. centuries, including leap year calculations, provided that all other technology used in combination with said product properly exchanges date data with it. DIGITAL-LOGIC makes no representation about individual components within the product should be used independently from the product as a whole. You should understand that DIGITAL-LOGIC's statement that an DIGITAL-LOGIC product is "YEAR 2000 CAPABLE" means only that DIGITAL-LOGIC has verified that the product as a whole meet this definition when tested as a stand-alone product in a test lab, but does not mean that DIGITAL-LOGIC has verified that the product is "YEAR 2000 CAPABLE" as used in your particular situation or configuration. DIGITAL-LOGIC makes no representation about individual components, including software, within the product should they be used independently from the product as a whole.

DIGITAL-LOGIC customers use DIGITAL-LOGIC products in countless different configurations and in conjunction with many other components and systems, and DIGITAL-LOGIC has no way to test whether all those configurations and systems will properly handle the transition to the year 2000. DIGITAL-LOGIC encourages its customers and others to test whether their own computer systems and products will properly handle the transition to the year 2000.

The only proper method of accessing the date in systems is indirectly from the Real-Time-Clock via the BIOS. The BIOS in DIGITAL-LOGIC computerboards contain a century checking and maintenance feature that checks the last two significant digits of the year stored in the RTC during each BIOS request (INT 1A) to read the date and, if less than '80' (i.e. 1980 is the first year supported by the PC), updates the century byte to '20'. This feature enables operating systems and applications using BIOS date/time services to reliably manipulate the year as a four-digit value.

2.7 Mechanical Dimensions

2.7.1 Board version V2.1/2.2

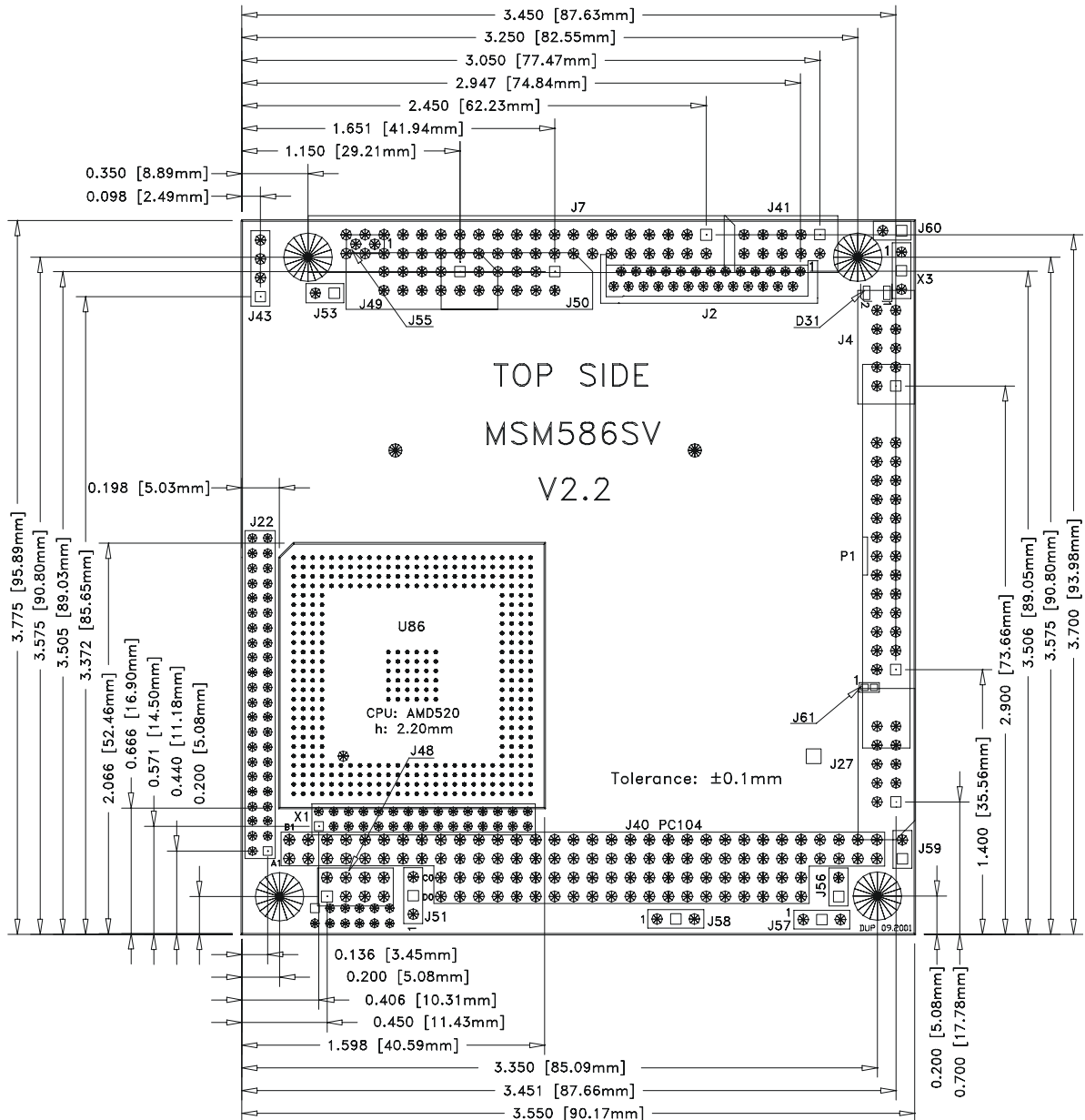

2.7.2 Board version V2.1/2.2

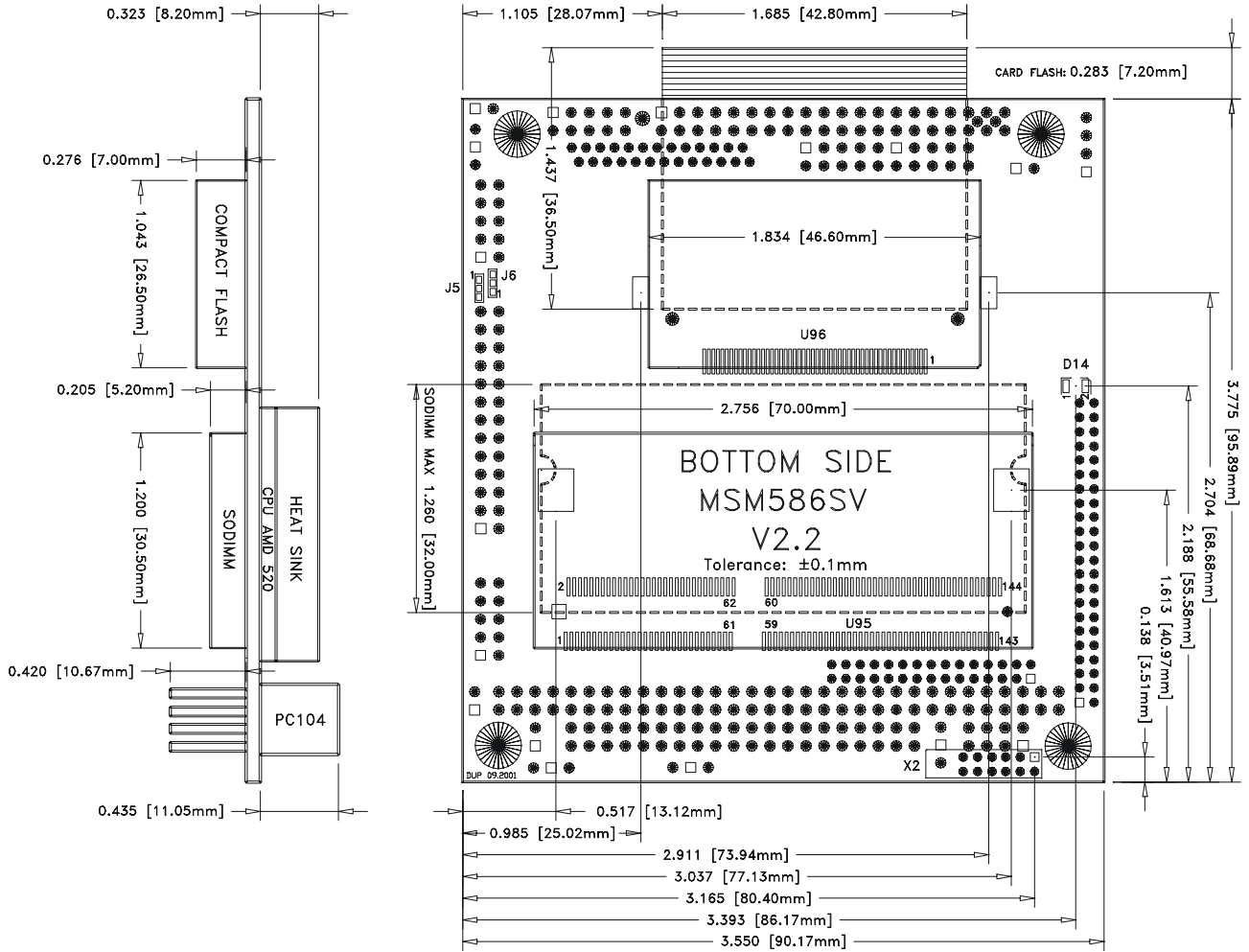

2.8 Incompatibilities to a standard PC/AT

INCOMPATIBILITIES ARE OBSERVED, ASK AMD FOR DETAILS !

2.9 Related application notes

#	Description
84	Power consumption on Pentium / any other boards with attached drives (HDD, CD)
96	MSM586SEN/SEV upgrades on V1.2

→ Application Notes are available at <http://www.digitallogic.com> -> Support, or on any Application CD from DIGITAL-LOGIC.

2.10 Ordering codes

To get the actual status of the partnumbers, customers are advised to ask for them via our sales department or distributors.

2.11 Thermoscan

With standard cooler:



2.12 High frequency radiation (to meet EN55022)

Since the PC/104 CPU modules are very high integrated embedded computers, no peripheral lines are protected against the radiation of high frequency spectrum. To meet a typical EN55022 requirement, all peripherals, they are going outside of the computer case, must be filtered externally.

Typical signals, they must be filtered:

Keyboard: KBCLK, KBDATA, VCC
 Mouse: MSCLK, MSDATA, VCC
 COM1/2/3/4: All serial signals must be filtered
 LPT: All parallel signals must be filtered
 CRT: red,blue,green, hsync, vsynch must be filtered

Typical signals, they must not be filtered, since they are internally used:

IDE: connected to the harddisk
 Floppy: connected to the floppy
 LCD: connected to the internal LCD

1. For peripheral cables:

Use for all DSUB connector a filtered version. Select carefully the filter specifications. Place the filtered DSUB connector directly frontside and be shure that the shielding makes a good contact with the case.

9pin DSUB connector from AMPHENOL:	FCC17E09P	820pF
25pin DSUB connector from AMPHENOL:	FCC17B25P	820pF

2. For stackthrough applications:

Place on each peripheral signal line, they are going outside, a serial inductivity and after the inductivity a capacitor of 100pF to 1000pF to ground. In this case, no filtered connectors are needed. Place the filter directly under or behind the onboard connector.

Serial Inductivity:	TDK HF50ACB321611-T	100Mhz, 500mA, 1206 Case
Ground capacitor:	Ceramic Capacitor with 1000pF	

Power supply:

Use a currentcompensated dualinductor on the 5V supply

SIEMENS B82721-K2362-N1 with 3.6A , 0.4mH

3 PC/104 BUS SIGNALS

Please note, that may not all of the signals are available on this board (check chapter "Description of the connectors")

AEN, output

Address Enable is used to degate the microprocessor and other devices from the I/O channel to allow DMA transfers to take place. **low = CPU Cycle , high = DMA Cycle**

BALE, output

Address Latch Enable is provided by the bus controller and is used on the system board to latch valid addresses and memory decodes from the microprocessor. This signal is used so that devices on the bus can latch LA17..23. The SA0..19 address lines latched internally according to this signal. BALE is forced high during DMA cycles.

/DACK[0..3, 5..7], output

DMA Acknowledge 0 to 3 and 5 to 7 are used to acknowledge DMA requests (DRQ0 through DRQ7). They are **active low**. This signal indicates that the DMA operation can begin.

Not available on ELAN520 (DACK5..7)

DRQ[0..3, 5..7], input

DMA Requests 0 through 3 and 5 through 7 are asynchronous channel requests used by peripheral devices and the I/O channel microprocessors to gain DMA service (or control of the system). A request is generated by bringing a DRQ line to an active level. A DRQ line must be held high until the corresponding DMA Request Acknowledge (DACK/) line goes active. DRQ0 through DRQ3 will perform 8-Bit DMA transfers; DRQ5-7 are used for 16 accesses.

Not available on ELAN520 (DRQ5..7)

/IOCHCK, input

IOCHCK/ provides the system board with parity (error) information about memory or devices on the I/O channel. **low = parity error, high = normal operation**

IOCHRDY, input

I/O Channel Ready is pulled low (not ready) by a memory or I/O device to lengthen I/O or memory cycles. Any slow device using this line should drive it low immediately upon detecting its valid address and a Read or Write command. Machine cycles are extended by an integral number of one clock cycle (67 nanoseconds). This signal should be held in the range of 125-15600nS. **low = wait, high = normal operation**

/IOCS16, input

I/O 16 Bit Chip Select signals the system board that the present data transfer is a 16-Bit, 1 wait-state, I/O cycle. It is derived from an address decode. /IOCS16 is **active low** and should be driven with an open collector (300 ohm pull-up) or tri-state driver capable of sinking 20mA. The signal is driven based only on SA15-SAO (not /IOR or /IOW) when AEN is not asserted. In the 8 Bit I/O transfer, the default transfers a 4 wait-state cycle.

/IOR, input/output

I/O Read instructs an I/O device to drive its data onto the data bus. It may be driven by the system microprocessor or DMA controller, or by a microprocessor or DMA controller resident on the I/O channel. This signal is **active low**.

/IOW, input/output

I/O Write instructs an I/O device to read the data on the data bus. It may be driven by any microprocessor or DMA controller in the system. This signal is **active low**.

IRQ[3 - 7, 9 - 12, 14, 15], input

These signals are used to tell the microprocessor that an I/O device needs attention. An interrupt request is generated when an IRQ line is **raised from low to high**. The line must be held high until the microprocessor acknowledges the interrupt request.

/Master, input

This signal is used with a DRQ line to gain control of the system. A processor or DMA controller on the I/O channel may issue a DRQ to a DMA channel in cascade mode and receive a /DACK.

Not available on ELAN520

/MEMCS16, input

MEMCS16 Chip Select signals the system board if the present data transfer is a 1 wait-state, 16-Bit, memory cycle. It must be derived from the decode of LA17 through LA23. /MEMCS16 should be driven with an open collector (300 ohm pull-up) or tri-state driver capable of sinking 20mA.

/MEMR input/output

These signals instruct the memory devices to drive data onto the data bus. /MEMR is active on all memory read cycles. /MEMR may be driven by any microprocessor or DMA controller in the system. When a microprocessor on the I/O channel wishes to drive /MEMR, it must have the address lines valid on the bus for one system clock period before driving /MEMR active. These signals are **active low**.

/MEMW, input/output

These signals instruct the memory devices to store the data present on the data bus. /MEMW is active in all memory read cycles. /MEMW may be driven by any microprocessor or DMA controller in the system. When a microprocessor on the I/O channel wishes to drive /MEMW, it must have the address lines valid on the bus for one system clock period before driving /MEMW active. Both signals are **active low**.

OSC, output

Oscillator (OSC) is a high-speed clock with a 70 nanosecond period (14.31818 MHz). This signal is not synchronous with the system clock. It has a 50% duty cycle. OSC starts 100µs after reset is inactive.

RESETDRV, output

Reset Drive is used to reset or initiate system logic at power-up time or during a low line-voltage outage. This signal is active high. When the signal is active all adapters should turn off or tri-state all drivers connected to the I/O channel. This signal is driven by the permanent Master.

/REFRESH, input/output

These signals are used to indicate a refresh cycle and can be driven by a microprocessor on the I/O channel. These signals are **active low**.

ELAN520 pullup this signal with 1kΩ

SAO-SA19, LA17 - LA23 input/output

Address bits 0 through 19 are used to address memory and I/O devices within the system. These 20 address lines, allow access of up to 1MBytes of memory. SAO through SA19 are gated on the system bus when BALE is high and are latched on the falling edge of BALE. LA17 to LA23 are not latched and addresses the full 16 MBytes range. These signals are generated by the microprocessors or DMA controllers. They may also be driven by other microprocessor or DMA controllers that reside on the I/O channel. The SA17-SA23 are always LA17-LA23 address timings for use with the MSCS16 signal. This is advanced AT96 design. The timing is selectable with jumpers LAXx or SAXx.

/SBHE, input/output

Bus High Enable (system) indicates a transfer of data on the upper byte of the data bus, XD8 through XD15. Sixteen-Bit devices use /SBHE to condition data-bus buffers tied to XD8 through XD15.

SD[O..15], input/output

These signals provide bus bits 0 through 15 for the microprocessor, memory, and I/O devices. DO is the least-significant Bit and D15 is the most significant Bit. All 8-Bit devices on the I/O channel should use DO through D7 for communications to the microprocessor. The 16-Bit devices will use DO through D15. To support 8-Bit device, the data on D8 through D15 will be gated to DO through D7 during 8-Bit transfers to these devices; 16-Bit microprocessor transfers to 8-Bit devices will be converted to two 8-Bit transfers.

/SMEMR input/output

These signals instruct the memory devices to drive data onto the data bus for the first MByte. /SMEMR is active on all memory read cycles. /SMEMR may be driven by any microprocessor or DMA controller in the system. When a microprocessor on the I/O channel wishes to drive /SMEMR, it must have the address lines valid on the bus for one system clock period before driving /SMEMR active. The signal is **active low**.

/SMEMW, input/output

These signals instruct the memory devices to store the data present on the data bus for the first MByte. /SMEMW is active in all memory read cycles. /SMEMW may be driven by any microprocessor or DMA controller in the system. When a microprocessor on the I/O channel wishes to drive /SMEMW, it must have the address lines valid on the bus for one system clock period before driving /SMEMW active. Both signals are **active low**.

SYSCLK, output

This is a 8.25 MHz system clock. It is a synchronous microprocessor cycle clock with a cycle time of 167 nanoseconds. The clock has a 66% duty cycle. This signal should only be used for synchronization.

Available on ELAN520, since boardversion V2.2

TC output

Terminal Count provides a pulse when the terminal count for any DMA channel is reached. The TC completes a DMA-Transfer. This signal is expected by the onboard floppy disk controller. Do not use this signal, because it is internally connected to the floppy controller.

/OWS, input

The Zero Wait State (/OWS) signal tells the microprocessor that it can complete the present bus cycle without inserting any additional wait cycles. In order to run a memory cycle to a 16-Bit device without wait cycles, /OWS is derived from an address decode gated with a Read or Write command. In order to run a memory cycle to an 8-Bit device with a minimum of one-wait states, /OWS should be driven active one system clock after the Read or Write command is active, gated with the address decode for the device. Memory Read and Write commands to an 8-Bit device are active on the falling edge of the system clock. /OWS is **active low** and should be driven with an open collector or tri-state driver capable of sinking 20mA.

Not available on ELAN520

12V +/- 5%

used only for the flatpanel supply.

GROUND = 0V

used for the entire system.

VCC, +5V +/- 0.25V

for logic and harddisk/floppy supply.

→ *For further Informations about PC/104 and PC/104plus, please refer to the PC/104 specification manual which is available on the internet. <http://www.digitallogic.com> (manuals)*

3.1 Bus levels

The bus currents are as follows:

Output Signals:	IOH:	IOL:
D0 - D16	8 mA	8 mA
A0 - A23	8 mA	8 mA
MR, MW, IOR, IOW, RES, ALE, AEN, C14	8 mA	8 mA
DACKx, DRQx, INTx, PSx, OPW	8 mA	8 mA

Output Signals:	Logic Family:	Voltage:
Input Signals:	ABT-Logic ViH (min.) = 2.15 V	ABT-Logic Vil (max.) = 0.85 V

4 DETAILED SYSTEM DESCRIPTION

This system has a system configuration based on the ISA architecture. Check the I/O and the memory map in this chapter.

4.1 Power Requirements

The power is connected through the PC/104 power connector; or the separate power connector on the board. The supply uses only the +5 Volts and ground connection.

Warning: Make sure that the power plug is wired correctly before supplying power to the board! A built-in diode protects the board against reverse polarity.

Tolerance of 5V supply: 5 volts \pm 5%; Power-fail signal starts at \pm 10 % of 5 volt norm and generates a reset status for the MICROSPACE PC.

ATTENTION: With the harddisk connected to the IDE 44pin interface, the power requirement is high. The peak current must be enough to spin up the HD-motor. The typical spin-up current of the harddisk is 0.8 - 1.5Amp at 5V. Too little current will drop the voltage to under 5 volts for a short time. Due to this undervoltage, the system or the harddisk stops or falters. The VGA could also be "snowy".

The precise power requirements of the MICROSPACE MSM586SEV depend on a number of factors, including which functions are present on the board and which peripherals are connected to the board's I/O port. For example, AT-keyboards draw their power from the keyboard connector on the MICROSPACE MSM586SEV board, and therefore add keyboard current to the total power drawn by the board from its power supply.

Testenvironment for the powerconsumption measurement:

Peripherie:

Harddisk Hitachi Mod-DK23AA-60 DLAG: 890005
Monitor Compaq Mod-460
CompactFlash ONT-0515-0006 64MB DLAG: 890013
DOC2000 16 MB DLAG:
PS/2-KB Logitech Mod-iTouch Keyboard
PS/2-MS Logitech Mod-M-CAA43
Floppy TEAC Mod-FD-05HF

Software:

MS-DOS v6.22
Win98SE
HCT for Win98 v8.1 PerformanceTesttool from MICROSOFT

MSM586SEV

Current at +5Volt supply at -30°C/+25°C/+85°C

Mode	Memory	DLAG-Nr.	-30 °C	+25°C	+85 °C
MSM586SEV (DLAG: 801360)			[mA]	[mA]	[mA]
DOSv6.22: A:\	32MB/2 = 16 MB	890645 SDRAM	1290	1200	1200
	32 MB	890655 SDRAM	1150	1160	1160
	64 MB	890654 SDRAM	1180	1190	1200
DOSv6.22: EDIT running	32MB/2 = 16 MB	890645 SDRAM	1190	1200	1200
Autoexec.bat	32 MB	890655 SDRAM	1150	1170	1160
	64 MB	890654 SDRAM	1180	1200	1200
Win98SE: Desktop	32MB/2 = 16 MB	890645 SDRAM	1170	1140	1160
	32 MB	890655 SDRAM	1180	1160	1160
	64 MB	890654 SDRAM	1170	1160	1170
Win98SE: HCT v8.1	32MB/2 = 16 MB	890645 SDRAM	1470	1490	1520
System\Stress\Disk (Stress) c:\	32 MB	890655 SDRAM	1460	1490	1460
	64 MB	890654 SDRAM	1480	1470	1480

MSM586SEN

Current at +5Volt supply at -30°C/+25°C/+85°C

Mode	Memory	DLAG-Nr.	-30 °C	+25°C	+85 °C
MSM586-SEN (DLAG: 801350)			[mA]	[mA]	[mA]
DOSv6.22: A:\	32MB/2 = 16 MB	890645 SDRAM	970	880	870
	32 MB	890655 SDRAM	950	860	850
	64 MB	890654 SDRAM	970	880	850
DOSv6.22: EDIT running	32MB/2 = 16 MB	890645 SDRAM	970	880	880
Autoexec.bat	32 MB	890655 SDRAM	950	870	860
	64 MB	890654 SDRAM	970	890	870
Win98SE: Desktop	32MB/2 = 16 MB	890645 SDRAM	940	860	860
	32 MB	890655 SDRAM	950	860	850
	64 MB	890654 SDRAM	960	880	880
Win98SE: HCT v8.1	32MB/2 = 16 MB	890645 SDRAM	1290	1190	1150
System\Stress\Disk (Stress) c:\	32 MB	890655 SDRAM	1240	1190	1160
	64 MB	890654 SDRAM	1270	1200	1200

4.2 CPU, Boards and RAMs

4.2.1 CPUs of this MICROSPACE Product

Processor:	Type:	Clock:	Landmark MHz:	Landmark Units:
ELAN520	AMD	133 MHz		

4.2.2 Numeric Coprocessor

Is integrated into the ELAN520.

4.2.3 DRAM Memory

Speed:	70ns
Size:	SDRAM SODIMM144
Bits:	32 Bit
Capacity:	up to 128 MBytes
Bank:	1 - 4

4.3 Interface

4.3.1 Keyboard AT compatible and PS/2 Mouse

Pin	Signal
Pin 1	Speaker out
Pin 2	GND
Pin 3	Ext. reset input
Pin 4	VCC
Pin 5	Keyb. Data
Pin 6	Keyb. Clock
Pin 7	GND
Pin 8	External battery 3.0V
Pin 9	Mouse Clock (PS/2)
Pin 10	Mouse Data (PS/2)

4.3.2 Line Printer Port LPT1

A standard bi-directional LPT port is integrated into the MICROSPACE PC.

Further information about these signals is available in numerous publications, including the IBM technical reference manuals for the PC and AT computers and from some other reference documents.

The current is: IOH = 12 mA IOL = 24mA

The SUPER I/O 37B787 may be programmed via software commands.

4.3.3 Serial Ports COM1-COM4

The serial channels are fully compatible with 16C550 UARTS. COM1 is the primary serial port, and is supported by the board's ROM-BIOS as the PC-DOS 'COM1' device. The secondary serial port is COM2; it is supported as the 'COM2' device.

Standard: COM 1/2: ELAN520: 2 x 16C550 compatible serial interfaces
COM 3/4: 37B787: 2 x 16C550 compatible serial interfaces

Serial Port Connectors COM1, COM2, COM3, COM4

Pin	Signal Name	Function	in/out	DB25 Pin	DB9 Pin
1	CD	Data Carrier Detect	in	8	1
2	DSR	Data Set Ready	in	6	6
3	RXD	Receive Data	in	3	2
4	RTS	Request To Send	out	4	7
5	TXD	Transmit Data	out	2	3
6	CTS	Clear to Send	in	5	8
7	DTR	Data Terminal Ready	out	20	4
8	RI	Ring Indicator	in	22	9
9	GND	Signal Ground		7	5

The serial port signals are compatible with the RS232C specifications.

4.3.4 Floppy Disk Interface

The onboard floppy disk controller and ROM-BIOS support **one** floppy disk drive in any of the standard PC-DOS and MS-DOS formats shown in the table .

Supported Floppy Formats

Capacity	Drive size	Tracks	Data rate	DOS version
1.2 MB	5-1/4"	80	500 KHz	3.0 - 6.22
720 K	3-1/2"	80	250 KHz	3.2 - 6.22
1.44 M	3-1/2"	80	500 KHz	3.3 - 6.22

Floppy Interface Configuration

The desired configuration of floppy drives (number and type) must be properly initialized in the board's CMOS - configuration memory. This is generally done by using CTRL / ALT / S at bootup time.

Floppy Interface Connector

The table shows the pinout and signal definitions of the board's floppy disk interface connector. It is identical in pinout to the floppy connector of a standard AT. Note that, as in a standard PC or AT, both floppy drives are jumpered to the same drive select: as the 'second' drive. The drives are uniquely selected as a result of a swapping of a group of seven wires (conductors 10-16) that must be in the cable between the two drives. The seven-wire swap goes between the computer board and drive 'A'; the wires to drive 'B' are unswapped (or swapped a second time). The 26 pin high density (1mm pitch FCC) connector has only one drive and motor select. The onboard jumper defines the drive A:

Floppy Disk Interface Technology

We only support CMOS drives. That means that the termination resistors are 1 kohm. 5 1/4"-drives are not recommended (TTL interface).

The 26 pin connector: FFC/FPC 0.3mm thick 1.0mm (0.039") pitch (MOLEX 52030 Serie)

Floppy Disk Interface Connector

FD26: Pin	Signal Name	Function	in/out
1	VCC	+5 volts	
2	IDX	Index Pulse	in
3	VCC	+5 volts	
4	DS2	Drive Select 2	out
5	VCC	+5 volts	
6	DCHG	Disk Change	in
10	M02	Motor On 2	out
12	DIRC	Direction Select	out
14	STEP	Step	out
16	WD	Write Data	out
17	GND	Signal grounds	
18	WE	Write Enable	out
19	GND	Signal grounds	
20	TRKO	Track 0	in
21	GND	Signal grounds	
22	WP	Write Protect	in
23	GND	Signal grounds	
24	RDD	Read Data	in
25	GND	Signal grounds	
26	HS	Head Select	out

4.3.5 Speaker interface

One of the board's CPU device provides the logic for a PC compatible speaker port. The speaker logic signal is buffered by a transistor amplifier, and provides approximately 0.1 watt of audio power to an external 8 ohm speaker. Connect the speaker between VCC and speaker output to have no quiescent current.

4.4 Controllers

4.4.1 Interrupt Controllers

An 8259A compatible interrupt controller, within the ELAN520 chipset, provides seven prioritized interrupt levels. Some of these IRQ's are normally associated with the board's onboard device interfaces and controllers, and several are available on the AT expansion bus.

Interrupt	PIRQ	Sources:	onboard used:
IRQ0		ROM-BIOS clock tick function, from timer 0	yes
IRQ1	PIRQ1	Keyboard controller output buffer full	yes
IRQ2		Used for cascade 2. 8259	yes
IRQ3	PIRQ3	COM2 serial port; (COM C or COM D)	yes
IRQ4	PIRQ4	COM1 serial port; (COM C or COM D)	yes
IRQ5	PIRQ5	Free for user; (COM C or COM D)	(yes) *
IRQ6	PIRQ6	Floppy controller	yes
IRQ7	PIRQ7	LPT1 parallel printer; (COM C or COM D)	yes*
IRQ8	PIRQ8	Battery backed clock	yes
IRQ9	PIRQ9	Free for user	no
IRQ10	PIRQ10	Harddisk IDE	yes *
IRQ11	PIRQ0	Free for user	no *
IRQ12	PIRQ2	PS/2 mouse	yes
IRQ13		Math. coprocessor	yes
IRQ14	PIRQ10	Harddisk IDE	yes
IRQ15	PIRQ8	Free for user (HIGH ACTIVE)	no

- * It may depends on the BIOS settings configuration

4.5 Timers and Counters

4.5.1 Programmable Timers

An 8253 compatible timer/counter device is also included in the board's ASIC device. This device is utilized in precisely the same manner as in a standard AT implementation. Each channel of the 8253 is driven by a 1.190 MHz clock, derived from a 14.318 MHz oscillator, which can be internally divided in order to provide a variety of frequencies.

Timer 2 can also be used as a general purpose timer if the speaker function is not required.

Timer Assignment

Timer	Function
0	ROM-BIOS clock tick (18.2 Hz)
1	DRAM refresh request timing (15 μ s)
2	Speaker tone generation time base

4.5.2 Internal Battery backed clock (RTC)

An AT compatible date/time clock is located within the chipset. The device also contains a CMOS static RAM, compatible with that in standard ATs. System configuration data is normally stored in the clock chip's CMOS RAM in a manner consistent with the convention used in other AT compatible computers.

4.5.3 External Battery assembling:

- If customer wants to connect an external battery (check for the appropriate connector in the chapter 7 DESCRIPTION OF THE CONNECTORS),

4.5.3.1 Battery-Lifetime Version V2.1/V2.2

Battery specs:				
Manufacturer:	MAXELL			
Type:	ER10/28			
Nominal values:	3.6V / 410mAh / -55°C...~+85°C			

Information taken from the datasheet of MAXELL ER10/28

PRODUCT:	Temperatur °C	Battery voltage V	VCC (+5V) switched ON µA	VCC (+5V) switched OFF µA
MSM586SEV				
Battery current:	+25°C	3.65	0.00	7.85
	-40°C	3.52	0.00	5.48
	+85°C	3.78	4.37	40.31
Battery-Lifetime:	+25°C		> 10	4.5year
	-40°C		> 10	5.2year
	+85°C		> 10	1.0year

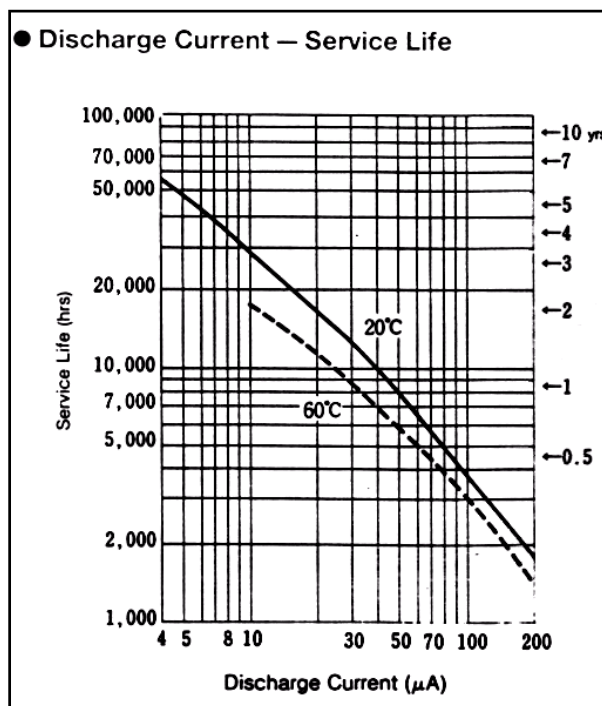

4.5.4 Watchdog

- The watchdog function is an implemented function of the ELAN520 and must be set/triggered by the application
- The watchdog is hardware triggered and will be activated also in case of a hanging system
- The watchdog is programmable between 0.5ms and 32sec
- The RESWDOG.CCP is a programming sample of how to do implement it into the customer's application. Any comments/explanations are integrated inside the file.
- There are no hardware modification necessary on the delivered and future boards to support watchdog function. This will be the standard watchdog function on our MSM586Sxx.

RESWDOG

```

#include <stdio.h>
#include <conio.h>
#include <dos.h>

void main()
{
unsigned char kk;
unsigned int tt = 0x10;//timeout = 4 Sec.
//TIMEOUT values:
// tt = 0 - invalid value
// tt = 0x01 - 0.5 uSec
// tt = 0x02 - 0.5 mSec
// tt = 0x04 - 1.0 Sec
// tt = 0x08 - 2.0 Sec
// tt = 0x10 - 4.0 Sec
// tt = 0x20 - 8.0 Sec
// tt = 0x40 - 16.0 Sec
// tt = 0x80 - 32.0 Sec

//pointer to address of WATCHDOG Timer Control
unsigned int far *ff = (unsigned int far*)MK_FP(0xE000,0xFCB0);//E000:FCB0

printf("Press ESC to quit\n");
//initialization sequence, enable WATCHDOG and assign the timeout (tt)
*ff = 0x3333;
*ff = 0xCCCC;
*ff = 0xC000 | tt;

//program body - user code
while(1)
{
if(kbhit())
{
if(getch() == 0x1B)return;//return to OS. In this sample,
//PC will reboot after 4 Sec.
}
printf("%02X\r",kk++);//nothing, just to do something
//.....
//"magic" sequence, for cleaning WATCHDOG counter
//the timing interval between such sequences must be
//not less than watchdog timeout(for this sample < 4 Sec)
*ff = 0xAAAA;
*ff = 0x5555;
}
}

```

4.6 Boottime

Testenvironment for the powerconsumption measurement:

Peripherie:

Harddisk Hitachi Mod-DK23AA-60 DLAG: 890005
 Monitor Compaq Mod-460
 CompactFlash ONT-0515-0006 64MB DLAG: 890013
 DOC2000 16 MB DLAG:
 PS/2-KB Logitech Mod-iTouch Keyboard
 PS/2-MS Logitech Mod-M-CAA43
 Floppy TEAC Mod-FD-05HF

Software:

MS-DOS v6.22
 Win98SE
 HCT for Win98 v8.1 PerformanceTesttool from MICROSOFT

Boot-Zeiten

Definitionen/Boot-Medium	Boot-Zeiten
MSM586SEV (DLAG: 801360) mit 64 MB SDRAM (890654)	Zeit [s]
Boot from Floppydisk:	
Boot ab Setup-Disk1 MS-DOS v6.22 bis „Starten von MS-DOS“-Prompt.	12
Boot ab Setup-Disk1 MS-DOS v6.22 bis „Willkommen zum Setup“-Prompt.	34
Boot ab „(Sys a:)-Disk“ bis „A:/>“-Prompt.	19
Boot from Harddisk-Hitachi Mod-DK23AA-60:	
Boot ab Harddisk bis „Win98SE: Windows-Anmeldung“-Prompt.	47
Boot from CompactFlash ONT-0515-0006 64MB:	
Boot ab CF bis „Starten von MS-DOS“-Prompt.	12
Boot ab CF bis „C:\>“-Prompt.	26
Boot from DOC2000 16MB – Bios: DOC BASE = D0000h:	
Boot ab DOC2000 bis WinCE-Desktop	20

Boot-Zeiten mit MSM586SEV getestet (Bios Ver. 1.21, Board Ver.: 2.1).

5 BIOS

More details are available in the separate BIOS manual on our CD and homepage !

5.1 ROM-BIOS sockets

An EPROM socket with 8 Bit wide data access normally contains the board's AT compatible ROM-BIOS. The socket takes a 29F40 EPROM (or equivalent) device. The board's wait-state control logic automatically inserts four memory wait states in all CPU accesses to this socket.

The ROM-BIOS sockets occupies the memory area from C0000H through FFFFFh; however, the board's ASIC logic reserves the entire area from C0000h through FFFFFh for onboard devices, so that this area is already usable for ROM-DOS and BIOS expansion modules.

Consult the appropriate address map for the MICROSPACE MSM586SEV ROM-BIOS sockets.

5.2 Standard BIOS ROM

Core BIOS device:	29F040	(U111) socket
VGA BIOS device:	29F010	(U155) soldered
MAP:	E0000 - FFFFFh	BIOS from INSYDE SOFT 128k
	C0000 - CBFFFh	VGA BIOS from Chips & Technology 48k
	CC000 - CFFFFh	Reserved

5.3 EEPROM Memory for Setup

The EEPROM is used for setup and configuration data, stored as an alternative to the CMOS-RTC. Optionally, the EEPROM setup driver may update the CMOS RTC, if the battery is running down and the checksum error would appear and stop the system. The capacity of the EEPROM is 2 kByte.

Organisation of the 2048Byte EEPROMs:

Address MAP:	Function:
0000h	CMOS-Setup valid (01=valid)
0001h	Keypress-Setup valid (01=valid)
0003h	Flag for DLAG-Message (FF=no message)
0010h-007Fh	Copy of CMOS-Setup data
0080h-00FFh	reserved for AUX-CMOS-Setup
0100h-010Fh	Serial-Number
0110h-0113h	Production date (year/day/month)
0114h-0117h	1. Service date (year/day/month)
0118h-011Bh	2. Service date (year/day/month)
011Ch-011Fh	3. Service date (year/day/month)
0120h-0122h	Booterrors (Autoincremented if any booterror occurs)
0123h-0125h	Setup Entries (Autoincremented on every Setup entry)
0126h-0128h	Low Battery (Autoincremented everytime the battery is low, EEPROM -> CMOS)
0129h-012Bh	Startup (Autoincremented on every poweron start)
0130h	Number of 512k SRAM
0131h	Number of 512k Flash
0132h/0133h	BIOS Version (V1.4 => [0132h]:= 4, [0133h]:=1)
0134h/0135h	BOARD Version (V1.5 => [0134h]:=5, [0135h]:=1)
0136h	BOARD TYPE ('M'=PC/104, 'E'=Euro, 'W'=MSWS, 'S'=Slot, 'C'=Custom)
0137h	CPU TYPE (01h=ELAN300/310, 02h=ELAN400, 03h=486SLC, 04h=486DX, 05h=P5).
0200h-03FFh	Keypress-Setup data
0200h-027Fh	Keypress Table
0400h-07FFh	Free for Customer's use

5.3.1 BIOS CMOS Setup

If wrong setups are memorized in the CMOS-RAM, the default values will be loaded after resetting the RTC/CMOS-RAM with the CMOS-RESET jumper. If the battery is down, it is always possible to start the system with the default values from the BIOS.

WARNING:

On the next setup pages (switch with TAB) the values for special parameters are modifiable. Normally the parameters are set correctly by DIGITAL-LOGIC AG. Be very careful in modifying any parameter since the system could crash. Some parameters are dependent on the CPU type. The cache parameter is always available, for example. So, if you select too few wait states, the system will not start until you reset the CMOS-RAM using the RAM-Reset jumper or dislodging the battery, but the default values are reloaded. If you are not familiar with these parameters, do not change anything!

5.4 CMOS RAM Map

Systems based on the industry-standard specification include a battery backed Real Time Clock chip. This clock contains at least 64 bytes of non-volatile RAM. The system BIOS uses this area to store information including system configuration and initialization parameters, system diagnostics, and the time and date. This information remains intact even when the system is powered down.

The BIOS supports 128 bytes of CMOS RAM. This information is accessible through I/O ports 70h and 71h. CMOS RAM can be divided into several segments:

- Locations 00h – 0Fh contain real time clock (RTC) and status information
- Locations 10h – 2Fh contain system configuration data
- Locations 30h – 3Fh contain System BIOS-specific configuration data as well as chipset-specific information
- Locations 40h – 7Fh contain chipset-specific information as well as power management configuration parameters

The following table provides a summary of how these areas may be further divided.

Beginning	Ending	Checksum	Description
00h	0Fh	No	RTC and Checksum
10h	2Dh	Yes	System Configuration
2Eh	2Fh	No	Checksum Value of 10h – 2Dh
30h	33h	No	Standard CMOS
34h	3Fh	No	Standard CMOS – SystemSoft Reserved
40h	5Bh	Yes	Extended CMOS – Chipset Specific
5Ch	5Dh	No	Checksum Value of 40h – 5Bh
5Eh	6Eh	No	Extended CMOS – Chipset Specific
6Fh	7Dh	Yes	Extended CMOS – Power Management
7Eh	7Fh	No	Checksum Value of 6Fh – 7Dh

Location	Description
00h	Time of day (seconds) specified in BCD
01h	Alarm (seconds) specified in BCD
02h	Time of Day (minutes) specified in BCD
03h	Alarm (minutes) specified in BCD
04h	Time of Day (hours) specified in BCD
05h	Alarm (hours) specified in BCD
06h	Day of week specified in BCD
07h	Day of month specified in BCD
08h	Month specified in BCD
09h	Year specified in BCD
0Ah	Status Register A Bit 7 = Update in progress Bits 6-4 = Time based frequency divider Bits 3-0 = Rate selection bits that define the periodic interrupt rate and output frequency.
0Bh	Status Register B Bit 7 = Run/Halt - Run - Halt Bit 6 = Periodic Timer - Disable - Enable Bit 5 = Alarm Interrupt - Disable - Enable Bit 4 = Update Ended Interrupt - Disable - Enable Bit 3 = Square Wave Interrupt - Disable - Enable Bit 2 = Calendar Format - BCD - Binary Bit 1 = Time Format - 12-Hour - 24-Hour Bit 0 = Daylight Savings Time - Disable 1 Enable
0Ch	Status Register C Bit 7 = Interrupt Flag Bit 6 = Periodic Interrupt Flag Bit 5 = Alarm Interrupt Flag Bit 4 = Update Interrupt Flag Bits 3-0 = Reserved
0Dh	Status Register D Bit 7 = Real Time Clock - Lost Power 1 Power

Continued...

CMOS Map Continued...

Location	Description
0Eh	CMOS Location for Bad CMOS and Checksum Flags bit 7 = Flag for CMOS Lost Power 0 = Power OK 1 = Lost Power bit 6 = Flag for CMOS checksum bad 0 = Checksum is valid 1 = Checksum is bad
0Fh	Shutdown Code
10h	Diskette Drives bits 7-4 = Diskette Drive A 0000 = Not installed 0001 = Drive A = 360 K 0010 = Drive A = 1.2 MB 0011 = Drive A = 720 K 0100 = Drive A = 1.44 MB 0101 = Drive A = 2.88 MB bits 3-0 = Diskette Drive B 0000 = Not installed 0001 = Drive B = 360 K 0010 = Drive B = 1.2 MB 0011 = Drive B = 720 K 0100 = Drive B = 1.44 MB 0101 = Drive B = 2.88 MB
11h	Reserved
12h	Fixed (Hard) Drives bits 7-4 = Hard Drive 0, AT Type 0000 = Not installed - Types 1 – 14 1111 = Extended drive types 16-44. See location 19h. bits 3-0 = Hard Drive 1, AT Type 0000 = Not installed - Types 1 – 14 1111 = Extended drive types 16-44. See location 2Ah. See the <i>Fixed Drive Type Parameters Table</i> in Chapter 2 for information on drive types 16-44.
13h	Reserved

Continued...

CMOS Map Continued...

Location	Description
14h	<p>Equipment</p> <p>bits 7-6 = Number of Diskette Drives</p> <p>00 = One diskette drive</p> <p>01 = Two diskette drives</p> <p>10, 11 = Reserved</p> <p>bits 5-4 = Primary Display Type</p> <p>00 = Adapter with option ROM</p> <p>01 = CGA in 40 column mode</p> <p>10 = CGA in 80 column mode</p> <p>11 = Monochrome</p> <p>bits 3-2 = Reserved</p> <p>bit 1 = Math Coprocessor Presence</p> <p>0 = Not installed</p> <p>1 = Installed</p> <p>bit 0 = Bootable Diskette Drive</p> <p>0 = Not installed</p> <p>1 = Installed</p>
15h	Base Memory Size (in KB) – Low Byte
16h	Base Memory Size (in KB) – High Byte
17h	Extended Memory Size in (KB) – Low Byte
18h	Extended Memory Size (in KB) – High Byte
19h	<p>Extended Drive Type – Hard Drive 0</p> <p>See the <i>Fixed Drive Type Parameters Table</i> in Chapter 2 for information on drive types 16-44.</p>
1Ah	<p>Extended Drive Type – Hard Drive 1</p> <p>See the <i>Fixed Drive Type Parameters Table</i> in Chapter 2 for information on drive types 16-44.</p>
1Bh	<p>Custom and Fixed (Hard) Drive Flags</p> <p>bits 7-6 = Reserved</p> <p>bit 5 = Internal Floppy Diskette Controller</p> <p>0 = Disabled</p> <p>1 = Enabled</p> <p>bit 4 = Internal IDE Controller</p> <p>0 = Disabled</p> <p>1 = Enabled</p> <p>bit 3 = Hard Drive 0 Custom Flag</p> <p>0 = Disable</p> <p>1 = Enabled</p> <p>bit 2 = Hard Drive 0 IDE Flag</p> <p>0 = Disable</p> <p>1 = Enabled</p> <p>bit 1 = Hard Drive 1 Custom Flag</p> <p>0 = Disable</p> <p>1 = Enabled</p> <p>bit 0 = Hard Drive 1 IDE Flag</p> <p>0 = Disable</p> <p>1 = Enabled</p>

Continued...

CMOS Map Continued...

Location	Description
1Ch	Reserved
1Dh	EMS Memory Size Low Byte
1Eh	EMS Memory Size High Byte
1Fh – 24h	Custom Drive Table 0 These 6 bytes (48 bits) contain the following data: Cylinders Landing Zone 10 bits Write Precomp 10 bits Heads Sectors/Track 8 bits
1Fh	Byte 0 bits 7-0 = Lower 8 Bits of Cylinders
20h	Byte 1 bits 7-2 = Lower 6 Bits of Landing Zone bits 1-0 = Upper 2 Bits of Cylinders
21h	Byte 2 bits 7-4 = Lower 4 Bits of Write Precompensation bits 3-0 = Upper 4 Bits of Landing Zone
22h	Byte 3 bits 7-6 = Reserved bits 5-0 = Upper 6 Bits of Write Precompensation
23h	Byte 4 bits 7-0 = Number of Heads
24h	Byte 5 bits 7-0 = Sectors Per Track
25h – 2Ah	Custom Drive Table 1 These 6 bytes (48 bits) contain the following data: Cylinders Landing Zone 10 bits Write Precomp 10 bits Heads Sectors/Track 8 bits
25h	Byte 0 bits 7-0 = Lower 8 Bits of Cylinders
26h	Byte 1 bits 7-2 = Lower 6 Bits of Landing Zone bits 1-0 = Upper 2 Bits of Cylinders
27h	Byte 2 bits 7-4 = Lower 4 Bits of Write Precompensation bits 3-0 = Upper 4 Bits of Landing Zone

Continued...

CMOS Map Continued...

Location	Description
28h	Byte 3 bits 7-6 = Reserved bits 5-0 = Upper 6 Bits of Write Precompensation
29h	Byte 4 bits 7-0 = Number of Heads
2Ah	Byte 5 bits 7-0 = Sectors Per Track
2Bh	Boot Password bit 7 = Enable/Disable Password 0 = Disable Password 1 = Enable Password bits 6-0 = Calculated Password
2Ch	SCU Password bit 7 = Enable/Disable Password 0 = Disable Password 1 = Enable Password bits 6-0 = Calculated Password
2Dh	Reserved
2Eh	High Byte of Checksum – Locations 10h to 2Dh
2Fh	Low Byte of Checksum – Locations 10h to 2Dh
30h	Extended RAM (KB) detected by POST – Low Byte
31h	Extended RAM (KB) detected by POST – High Byte
32h	BCD Value for Century
33h	Base Memory Installed bit 7 = Flag for Memory Size 0 = 640KB 1 = 512KB bits 6-0 = Reserved
34h	Minor CPU Revision Differentiates CPUs within a CPU type (i.e., 486SX vs 486 DX, vs 486 DX/2). This is crucial for correctly determining CPU input clock frequency. During a power on reset, Reg DL holds minor CPU revision.
35h	Major CPU Revision Differentiates between different CPUs (i.e., 386, 486, Pentium). This is crucial for correctly determining CPU input clock frequency. During a power on reset, Reg DH holds major CPU revision.
36h	Hotkey Usage bits 7-6 = Reserved bit 5 = Semaphore for Completed POST bit 4 = Semaphore for 0 Volt POST (not currently used) bit 3 = Semaphore for already in SCU menu bit 2 = Semaphore for already in PM menu bit 1 = Semaphore for SCU menu call pending bit 0 = Semaphore for PM menu call pending
40h-7Fh	Definitions for these locations vary depending on the chipset.

5.5 *EEPROM saved CMOS setup*

The EEPROM has different functions, as listed below:

- Backup of the CMOS-Setup values.
- Storing system informations like: version, production date, customisation of the board, CPU type.
- Storing user/application values.

If the system hangs or a problem appears, the following steps must be performed:

1. Reset the CMOS-Setup (use the jumper to reset or disconnect the battery for at least 10 minutes).
2. Press Esc until the system starts up.
3. Enter the BIOS Setup:
 - a) load DEFAULT values
 - b) enter the settings for the environment
 - c) exit the setup
4. Restart the system.

- The user may access the EEPROM through the INT15 special functions. Refer to the chapter SFI functions.
- The system information are read onyl information. To read, use the SFI functions.

5.6 CORE - BIOS download function

Before downloading a BIOS, please check as follows:

- Select the Shadow option in the BIOS for BIOS and VGA (if this option is available).
- Disable the EMM386 or other memory managers in the CONFIG.SYS of your bootdisk.
- Make sure, that the DOWN_030.EXE programm and the BIOS to download are on the same path and directory!
- Boot the DOS without config.sys & autoexec.bat -> press "F5" while starting DOS boot.
- Is the empty disk space, where the down.exe is located, larger than 64kB (for safe storage)
- Is the floppydisk not write-protected

Start the DOWNLOADING tool with:

- Start the corresponding download tool. Refer to the table to see which tool fits in, each productgroup has its own download tool. Do never use the wrong one!

Product:	BIOS-Core download	VGA-BIOS download	BIOS-Ext. download
File-Extension:	*.COR	*.V40 , *.V45 *.V48 depending on the product	*.BIN
BIOS Size:	128k	32k	32k
Addressrange:	E0000 - FFFFFh	C0000 – C7FFFh	C8000 - CFFFFh
MSM586SEN / SEV / SL	flash520.exe	flash520.exe	-

Remarks:

** Core- file has to be renamed as written in brackets

*** If downloading with DOWN_030.EXE, disable first in BIOS /Memory Cache/Cache Video Bios Area

5.6.1 CORE BIOS download

Start the download tool to update a new CORE BIOS (≥ V1.20 and since boardversion V2.0):

1. Set jumper J58 to 1-2 (default) before powering up the board
2. Check, if you find the appropriate download tool and the CORE BIOS files on your disk, to get downloaded
Start the system with the SHADOW enabled (if available) and no EMM386 loaded
3. Insert the floppydisk with the download tool and all CORE-drivers
4. Start download tool to update the **CORE** BIOS: **FLASH520 xxxx.yyy**
5. After proceeding, switch off the power and restart the board (cold start)

5.6.2 VGA BIOS download function

The BIOS for the VGA must be downloaded, before a LCD is connected. This could be also a new LCD- display, which needs a corresponding VGA- BIOS.

How to download a VGA- BIOS (standard mode since BIOS version V1.20):

6. Set jumper J58 to 1-2 (default) before powering up the board
7. Check, if you find the appropriate download tool and the VGA BIOS files on your disk, to get downloaded
Refer to the VGABIOS.DOC for more information about the VGABIOS files
Start the system with the SHADOW enabled (if available) and no EMM386 loaded
8. Insert the floppydisk with the download tool and all VGA-drivers
9. Set jumper J58 to 2-3 after powering up the board
10. Start download tool to update the **VGA BIOS: FLASH520 -V xxxx.yyy**
11. After proceeding, switch off the power
12. Set jumper J58 to 1-2 and restart the board (cold start)

When updating a VGA BIOS, which is integrated in the CORE BIOS (≤ V1.20 and since boardversion V2.0), then there is a special procedure to follow as the VGA and CORE BIOS will now get separated into 2 devices (U111 and U155).

Follow also this procedure, when the VGA BIOS is corrupted .

1. Take off jumper J58 (no jumper set)
2. Check, if you find the appropriate download tool and the VGA and CORE BIOS files on your disk, to get downloaded
Refer to the VGABIOS.DOC for more information about the VGABIOS files
Start the system with the SHADOW enabled (if available) and no EMM386 loaded
3. Start download tool to update the new CORE BIOS (≥ V1.20) : **FLASH520 xxxx.yyy**
4. Reboot (cold start) and there will be no picture
5. Set jumper J58 to 2-3 while board is running
6. Start download tool to update the VGA BIOS: **FLASH520 -V xxxx.yyy.**
You may create this action by making a batch file as there is no picture or
you may use the REMOTE function to make this action
7. After proceeding, switch off the power
8. Set jumper J58 to 1-2 and restart the board (cold start)

If the download does not work:

- Check, if no EMM386 is loaded.
- Check, if no peripheral card is in the system, which occupies the same memory range. Disconnect this card.
- If the download is stopped or not completed, make only a warm boot and repeat the steps or download another file. As the video is may shadowed, everything is visible and a cold boot would clear the screen and nothing would be visible afterwards.

If the screen flickers or is misaligned after reboot:

- The previously loaded VGA- BIOS is not corresponding 100% or works only on the LCD properly.

If the screen is dark after the reboot of the system:

- A new system BIOS must be programmed. Ask DIGITAL-LOGIC AG for the binary file.

If the previous version is still programmed:

- Switch off the board and do not make a warm boot due to the fact that the data may are still stored in the memory shadow.

5.7 Memory

5.7.1 System Memory Map

The ELAN520 CPU used as central processing unit on the MICROSPACE has a memory address space which is defined by 32 address bits. Therefore, it can address 1 GByte of memory. The memory address MAP is as follows:

CPU

Address:	Size:	Function / Comments:
000000 - 09FFFFh	640 KBytes	Onboard DRAM for DOS applications
0A0000 - 0BFFFFh	128 KBytes	CGA, EGA, LCD Video RAM 128kB
0C0000 - 0CBFFFh	48 KBytes	VGA BIOS selected by the hardware
0CC000 - 0CFFFFh	16 KBytes	BIOS extensions selected by the hardware
0D0000 - 0D4000h	16 KBytes	free for user
0D4000 - 0D8000h	16 KBytes	free for user
0D8000 - 0DFFFFh	32 KBytes	free for user
0E0000 - 0EFFFFh	64 KBytes	BIOS
0F0000 - 0FFFFFFh	64 KBytes	BIOS
100000 - 1FFFFFFh	1 MByte	DRAM for extended onboard memory
200000 - FFFFFFFh	14 MBytes	DRAM for extended onboard memory

See also BIOS manual for additional details

5.7.2 System I/O map

The following table shows the detailed listing of the I/O port assignments used in the MICROSPACE board:

I/O Ad- dress	Read/Write Status	Description
0000h	R / W	DMA channel 0 address byte 0 (low), then byte 1
0001h	R / W	DMA channel 0 word count byte 0 (low), then byte 1
0002h	R / W	DMA channel 1 address byte 0 (low), then byte 1
0003h	R / W	DMA channel 1 word count byte 0 (low), then byte 1
0004h	R / W	DMA channel 2 address byte 0 (low), then byte 1
0005h	R / W	DMA channel 2 word count byte 0 (low), then byte 1
0006h	R / W	DMA channel 3 address byte 0 (low), then byte 1
0007h	R / W	DMA channel 3 word count byte 0 (low), then byte 1
0008h	R	DMA channel 0-3 status register bit 7 = 1 Channel 3 request bit 6 = 1 Channel 2 request bit 5 = 1 Channel 1 request bit 4 = 1 Channel 0 request bit 3 = 1 Terminal count on channel 3 bit 2 = 1 Terminal count on channel 2 bit 1 = 1 Terminal count on channel 1 bit 0 = 1 Terminal count on channel 0

Continued...

I/O Address	Read/Write Status	Description
0008h	W	DMA channel 0-3 command register bit 7 = DACK sense active high/low 0 low 1 high bit 6 = DREQ sense active high/low 0 low 1 high bit 5 = Write selection 0 Late write selection 1 Extended write selection bit 4 = Priority 0 Fixed 1 Rotating bit 3 = Timing 0 Normal 1 Rotating bit 2 = Controller enable/disable 0 Enable 1 Disable bit 1 = Memory-to-memory enable/disable 0 Disable 1 Enable bit 0 = Reserved
0009h	W	DMA write request register
000Ah	R / W	DMA channel 0-3 mask register bits 7-3 = Reserved bit 2 = 0 Clear bit 1 Set bit bits 1-0 = Channel Select 00 Channel 0 01 Channel 1 10 Channel 2 11 Channel 3
00Bh	W	DMA channel 0-3 mode register bits 7-6 = 00 Demand mode 01 Single mode 10 Block mode 11 Cascade mode bit 5 = 0 Address increment select 1 Address decrement select bit 4 = 0 Disable auto initialization 1 Enable auto initialization bits 3-2 = Operation type 00 Verify operation 01 Write to memory 10 Read from memory 11 Reserved bits 1-0 = Channel select 00 Channel 0 01 Channel 1 10 Channel 2 11 Channel 3

Continued...

I/O Address	Read/Write Status	Description
000Ch	W	DMA clear byte pointer flip/flop
000Dh	R	DMA read temporary register
000Dh	W	DMA master clear
000Eh	W	DMA clear mask register
000Fh	W	DMA write mask register
0020h	W	<p>Programmable Interrupt Controller - Initialization Command Word 1 (ICW1) provided bit 4 = 1</p> <p>bits 7-5 = 000 Used only in 8080 or 8085 mode</p> <p>bit 4 = 1 ICW1 is used</p> <p>bit 3 = 0 Edge triggered mode 1 Level triggered mode</p> <p>bit 2 = 0 Successive interrupt vectors separated by 8 bytes 1 Successive interrupt vectors separated by 4 bytes</p> <p>bit 1 = 0 Cascade mode 1 Single mode</p> <p>bit 0 = 0 ICW4 not needed 1 ICW4 needed</p>
0021h	W	<p>Used for ICW2, ICW3, or ICW4 in sequential order after ICW1 is written to port 0020h</p> <p>ICW2</p> <p>bits 7-3 = Address A0-A3 of base vector address for interrupt controller</p> <p>bits 2-0 = Reserved (should be 000)</p> <p>ICW3 (for slave controller 00A1h)</p> <p>bits 7-3 = Reserved (should be 0000)</p> <p>bits 2-0 = 1 Slave ID</p> <p>ICW4</p> <p>bits 7-5 = Reserved (should be 000)</p> <p>bit 4 = 0 No special fully nested mode 1 Special fully nested mode</p> <p>bits 3-2 = Mode</p> <p>00 Non buffered mode 01 Non buffered mode 10 Buffered mode/slave 11 Buffered mode/master</p> <p>bit 1 = 0 Normal EOI 1 Auto EOI</p> <p>bit 0 = 0 8085 mode 1 8080 / 8088 mode</p>

Continued...

I/O Address	Read/Write Status	Description
0021h	R / W	PIC master interrupt mask register (OCW1) bit 7 = 0 Enable parallel printer interrupt bit 6 = 0 Enable diskette interrupt bit 5 = 0 Enable hard disk interrupt bit 4 = 0 Enable serial port 1 interrupt bit 3 = 0 Enable serial port 2 interrupt bit 2 = 0 Enable video interrupt bit 1 = 0 Enable kybd/pointing device/RTC interrupt bit 0 = 0 Enable interrupt timer
0021h	W	PIC OWC2 (if bits 4-3 = 0) bit 7 = Reserved bits 6-5 = 000 Rotate in automatic EOI mode (clear) 001 Nonspecific EOI 010 No operation 011 Specific EOI 100 Rotate in automatic EOI mode (set) 101 Rotate on nonspecific EOI command 110 Set priority command 111 Rotate on specific EOI command bits 4-3 = Reserved (should be 00) bits 2-0 = Interrupt request to which the command applies
0020h	R	PIC interrupt request and in-service registers programmed by OCW3 Interrupt request register bits 7-0 = 0 No active request for the corresponding interrupt line 1 Active request for the corresponding interrupt line Interrupt in-service register bits 7-0 = 0 Corresponding interrupt line not currently being serviced 1 Corresponding interrupt line is currently being serviced
0021h	W	PIC OCW3 (if bit 4 = 0, bit 3 = 1) bit 7 = Reserved (should 0) bits 6-5 = 00 No operation 01 No operation 10 Reset special mask 11 Set special mask bit 4 = Reserved (should be 0) bit 3 = Reserved (should be 1) bit 2 = 0 No poll command 1 Poll command bits 1-0 = 00 No operation 01 Operation 10 Read interrupt request register on next read at port 0020 h 11 Read interrupt in-service register on next read at port 0020h

Continued...

I/O Address	Read/Write Status	Description
0022h	R / W	Chipssset Register Adress
0023h	R / W	Chipssset Register Data
0040h	R / W	Programmable Interrupt Time read/write counter 0, keyboard controller channel 0
0041h	R / W	Programmer Interrupt Timer channel 1
0042h	R / W	Programmable Interrupt Timer miscellaneous register channel 2
0043h	W	<p>Programmable Interrupt Timer mode port - control word register for counters 0 and 2</p> <p>bits 7-0 = Counter select</p> <p>00 Counter 0 select</p> <p>01 Counter 1 select</p> <p>10 Counter 2 select</p> <p>bits 5-4 = Counter latch command</p> <p>01 R / W counter, bits 0-7 only</p> <p>10 R / W counter, bits 8-15 only</p> <p>11 R / W counter, bits 0-7 first, then bits 8-15</p> <p>bits 3-1 = Select mode</p> <p>000 Mode 0</p> <p>001 Mode 1 programmable one shot</p> <p>x10 Mode 2 rate generator</p> <p>x11 Mode 3 square wave generator</p> <p>100 Mode 4 software-triggered strobe</p> <p>101 Mode 5 hardware-triggered strobe</p> <p>bit 0 = 0 Binary counter is 16 bits</p> <p>1 Binary counter decimal (BCD) counter</p>
0048h	R / W	Programmable interrupt timer
0060h	R	Keyboard controller data port or keyboard input buffer
0060h	W	Keyboard or keyboard controller data output buffer

Continued...

I/O Address	Read/Write Status	Description
0064h	R	Keyboard controller read status bit 7 = 0 No parity error 1 Parity error on keyboard transmission bit 6 = 0 No timeout 1 Received timeout bit 5 = 0 No timeout 1 Keyboard transmission timeout bit 4 = 0 Keyboard inhibited 1 Keyboard not inhibited bit 3 = 0 Data 1 Command bit 2 = System flag status bit 1 = 0 Input buffer empty 1 Input buffer full bit 0 = 0 Output buffer empty 1 Output buffer full
0064h	W	Keyboard controller input buffer
0070h	R	CMOS RAM index register port and NMI mask bit 7 = 1 NMI disabled bits 6-0 = 0 CMOS RAM index
0071h	R / W	CMOS RAM data register port
0080h	R / W	Temporary storage for additional page register
0080h	R	Manufacturing diagnostic port (this port can access POST checkpoints)
0081h	R / W	DMA channel 2 address byte 2
0082h	R / W	DMA channel 2 address byte 2
0083h	R / W	DMA channel 1 address byte 2
0084h	R / W	Extra DMA page register
0085h	R / W	Extra DMA page register
0086h	R / W	Extra DMA page register
0087h	R / W	DMA channel 0 address byte 2
0088h	R / W	Extra DMA page register
0089h	R / W	DMA channel 6 address byte 2
008Ah	R / W	DMA channel 7 address byte 2
008Bh	R / W	DMA channel 5 address byte 2
008Ch	R / W	Extra DMA page register
008Dh	R / W	Extra DMA page register
008Eh	R / W	Extra DMA page register
008Fh	R / W	DMA refresh page register

Continued...

I/O Address	Read/Write Status	Description
00A0h - 00A1h are reserved for the slave programmable interrupt controller. The bit definitions are identical to those of addresses 0020h - 0021h except where indicated.		
00A0h	R / W	Programmable interrupt controller 2
00A1h	R / W	Programmable interrupt controller 2 mask bit 7 = 0 Reserved bit 6 = 0 Enable hard disk interrupt bit 5 = 0 Enable coprocessor execution interrupt bit 4 = 0 Enable mouse interrupt bits 3-2 = 0 Reserved bit 1 = 0 Enable redirect cascade bit 0 = 0 Enable real time clock interrupt
00C0h	R / W	DMA channel 4 memory address bytes 1 and 0 (low)
00C2h	R / W	DMA channel 4 transfer count bytes 1 and 0 (low)
00C4h	R / W	DMA channel 5 memory address bytes 1 and 0 (low)
00C6h	R / W	DMA channel 5 transfer count bytes 1 and 0 (low)
00C8h	R / W	DMA channel 6 memory address bytes 1 and 0 (low)
00CAh	R / W	DMA channel 6 transfer count bytes 1 and 0 (low)
00CCh	R / W	DMA channel 7 memory address bytes 1 and 0 (low)
00CEh	R / W	DMA channel 7 transfer count bytes 1 and 0 (low)
00D0h	R	Status register for DMA channels 4-7 bit 7 = 1 Channel 7 request bit 6 = 1 Channel 6 request bit 5 = 1 Channel 5 request bit 4 = 1 Channel 4 request bit 3 = 1 Terminal count on channel 7 bit 2 = 1 Terminal count on channel 6 bit 1 = 1 Terminal count on channel 5 bit 0 = 1 Terminal count on channel 4
00D0h	W	Command register for DMA channels 4-7 bit 7 = 0 DACK sense active low 1 DACK sense active high bit 6 = 0 DREQ sense active low 1 DREQ sense active high bit 5 = 0 Late write selection 1 Extended write selection bit 4 = 0 Fixed Priority 1 Rotating Priority bit 3 = 0 Normal Timing 1 Rotating Timing bit 2 = 0 Enable controller 1 Disable controller bit 1 = 0 Disable memory-to-memory transfer 1 Enable memory-to-memory transfer bit 0 = Reserved

Continued...

I/O Address	Read/Write Status	Description
00D2h	W	Write request register for DMA channels 4-7
00D4h	W	Write single mask register bit for DMA channels 4-7 bits 7-3 = 0 Reserved bit 2 = 0 Clear mask bit, 1 Set mask bit bits 1-0 = Channel select 00 Channel 4 01 Channel 5 10 Channel 6 11 Channel 7
00D6h	W	Mode register for DMA channels 4-7 bits 7-6 = 00 Demand mode 01 Single mode 10 Block mode 11 Cascade mode bit 5 = 0 Address increment select 1 Address decrement select bit 4 = 0 Disable auto initialization 1 Enable auto initialization bits 3-2 = Operation type 00 Verify operation 01 Write to memory 10 Read from memory 11 Reserved bits 1-0 = Channel select 00 Channel 4 01 Channel 5 10 Channel 6 11 Channel 7
00D8h	W	Clear byte pointer flip/flop for DMA channels 4-7
00DAh	R	Read Temporary Register for DMA channels 4-7
00DAh	W	Master Clear for DMA channels 4-7
00DCh	W	Clear mask register for DMA channels 4-7
00DEh	W	Write mask register for DMA channels 4-7
00F0h	W	Math coprocessor clear busy latch
00F1h	W	Math coprocessor reset
00F2h - 00FFh	R / W	Math coprocessor
0140h - 014Fh	R / W	SCSI Controller if installed
I/O addresses 0170h - 0177h are reserved for use with a secondary hard drive. See addresses 01F0h - 01F7h for bit definitions.		
0170h	R / W	Data register for hard drive 1
0171h	R	Error register for hard drive 1
0171h	W	Precomposition register for hard drive 1
0172h	R / W	Sector count - hard drive 1

Continued...

I/O Address	Read/Write Status	Description
0173h	R / W	Sector number for hard disk 1
0174h	R / W	Number of cylinders (low byte) for hard drive 1
0175h	R / W	Number of cylinders (high byte) for hard drive 1
0716h	R / W	Drive/head register for hard drive 1
0177h	R	Status register for hard drive 1
0177h	W	Command register for hard drive 1
01F0h	R / W	Data register base port for hard drive 0
01F1h	R	<p>Error register for hard drive 0</p> <p>Diagnostic mode bits 7-3 = Reserved bits 2-0 = Errors 0001 No errors 0010 Controller error 0011 Sector buffer error 0100 ECC device error 0101 Control processor error</p> <p>Operation mode bit 7 = Block 0 Bad block 1 Block not bad bit 6 = Error 0 No error 1 Uncorrectable ECC error bit 5 = Reserved bit 4 = ID 0 ID located 1 ID not located bit 3 = Reserved bit 2 = Command 0 Completed 1 Not completed bit 1 = Track 000 0 Not found 1 Found bit 0 = DRAM 0 Not found 1 Found (CP-3022 always 0)</p>
01F1h	W	Write precomposition register for hard drive 0
01F2h	R / W	Sector count for hard disk 0
01F3h	R / W	Sector number for hard drive 0
01F4h	R / W	Number of cylinders (low byte) for hard drive 0
01F5h	R / W	Number of cylinders (high byte) for hard drive 0

Continued...

I/O Address	Read/Write Status	Description
01F6h	R / W	Drive/Head register for hard drive 0 bit 7 = 1 bit 6 = 0 bit 5 = 1 bit 4 = Drive select 0 First hard drive 1 Second hard drive bits 3-0 = Head select bits
01F7h	R	Status register for hard drive 0 bit 7 = 1 Controller is executing a command bit 6 = 1 Drive is ready bit 5 = 1 Write fault bit 4 = 1 Seek operation complete bit 3 = 1 Sector buffer requires servicing bit 2 = 1 Disk data read completed successfully bit 1 = Index (is set to 1 at each disk revolution) bit 0 = 1 Previous command ended with error
01F7h	W	Command register for hard drive 0
0200h - 020Fh	R / W	Game controller ports
0201h	R / W	I/O data - game port
0220h – 022Fh	R / W	Soundport AD1816 reserved
I/O addresses 0278h - 027Ah are reserved for use with parallel port 2. See the bit definitions for addresses 0378h - 037Ah.		
0278h	R / W	Data port for parallel port 2
0279h	R	Status port for parallel port 2
0279h	W	PnP Address register (only for PnP devices)
027Ah	R / W	Control port for parallel port 2
02B0h – 02BFh	R / W	Digital I/O for Latch, WDOG, Control
I/O addresses 02E8h - 02EFh are reserved for use with serial port 4. See the bit definitions for I/O addresses 03F8h - 03FFh.		
02E8h	W	Transmitter holding register for serial port 4
02E8h	R	Receive buffer register for serial port 4
02E8h	R / W	Baud rate divisor (low byte) when DLAB = 1
02E9h	R / W	Baud rate divisor (high byte) when DLAB = 1
02E9h	R / W	Interrupt enable register when DLAB = 0
02EAh	R	Interrupt identification register for serial port 4
02EBh	R / W	Line control register for serial port 4
02ECh	R / W	Modem control register for serial port 4
02EDh	R	Line status register for serial port 4
02EEh	R	Modem status register for serial port 4
02EFh	R / W	Scratch register for serial port 4 (used for diagnostics)

Continued...

I/O Address	Read/Write Status	Description
I/O addresses 02F8h - 02FFh are reserved for use with serial port 2. See the bit definitions for I/O addresses 03F8h - 03FFh.		
02F8h	W	Transmitter holding register for serial port 2
02F8h	R	Receive buffer register for serial port 2
02F8h	R / W	Baud rate divisor (low byte) when DLAB = 1
02F9h	R / W	Baud rate divisor (high byte) when DLAB = 1
02F9h	R / W	Interrupt enable register when DLAB = 0
02FAh	R	Interrupt identification register for serial port 2
02FBh	R / W	Line control register for serial port 2
02FCh	R / W	Modem control register for serial port 2
02FDh	R	Line status register for serial port 2
02FEh	R	Modem status register for serial port 2
02FFh	R / W	Scratch register for serial port 2 (used for diagnostics)
0300h – 031Fh	R / W	ISA- LAN controller, if installed (otherwise is free for the user)
I/O addresses 0372h - 0377h are reserved for use with a secondary diskette controller. See the bit definitions for 03F2h - 03F7h.		
0372h	W	Digital output register for secondary diskette drive controller
0374h	R	Status register for secondary diskette drive controller
0375h	R / W	Data register for secondary diskette drive controller
0376h	R / W	Control register for secondary diskette drive controller
0377h	R	Digital input register for secondary diskette drive controller
0377h	W	Select register for secondary diskette data transfer rate
0378h	R / W	Data port for parallel port 1 bit 7 = 0 Busy bit 6 = 0 Acknowledge bit 5 = 1 Out of paper bit 4 = 1 Printer is selected bit 3 = 0 Error bit 2 = 0 IRQ has occurred bit 1-0 = Reserved
0379h	R / W	Status port for parallel port 1 bit 7 = 0 Busy bit 6 = 0 Acknowledge bit 5 = 1 Out of paper bit 4 = 1 Printer is selected bit 3 = 0 Error bit 2 = 0 IRQ has occurred bit 1-0 = Reserved

Continued...

I/O Address	Read/Write Status	Description
037Ah	R / W	Control port for parallel port 1 bits 7-5 = Reserved bit 4 = 1 Enable IRQ bit 3 = 1 Select printer bit 2 = 0 Initialize printer bit 1 = 1 Automatic line feed bit 0 = 1 Strobe
03B0h - 03B8h	R / W	Various video registers
I/O addresses 03BCh - 03BEh are reserved for use with parallel port 3. See the bit definitions for addresses 0378h - 037Ah.		
03BCh	R / W	Data port - parallel port 3
03BDh	R / W	Status port - parallel port 3
03BEh	R / W	Control port - parallel port 3
03C0h - 03CFh	R / W	Video subsystem (EGA/VGA)
03C2h - 03D9h	R / W	Various CGA and CRTC registers
03E0h	R / W	PCCARD Address select
03E1h	R / W	PCCARD Data transfer with 365SL controller
I/O addresses 03E8h - 03EFh are reserved for use with serial port 3. See the bit definitions for I/O addresses 03F8h - 03FFh.		
03E8h	W	Transmitter holding register for serial port 3
03E8h	R	Receive buffer register for serial port 3
03E8h	R / W	Baud rate divisor (low byte) when DLAB = 1
03E9h	R / W	Baud rate divisor (high byte) when DLAB = 1
03E9h	R / W	Interrupt enable register when DLAB = 0
03EAh	R	Interrupt identification register for serial port 3
03EBh	R / W	Line control register for serial port 3
03ECh	R / W	Modem control register for serial port 3
03EDh	R	Line status register for serial port 3
03EEh	R	Modem status register for serial port 3
03EFh	R / W	Scratch register for serial port 3 (used for diagnostics)
03F2h	W	Digital output register for primary diskette drive controller bits 7-6 = 0 Reserved bit 5 = 1 Enable drive 1 motor bit 4 = 1 Enable drive 0 motor bit 3 = 1 Enable diskette DMA bit 2 = 0 Reset controller bit 1 = 0 Reserved bit 0 = 0 Select drive 0 1 Select drive 1

Continued...

I/O Address	Read/Write Status	Description
03F4h	R	Status register for primary diskette drive controller bit 7 = 1 Data register is ready bit 6 = 0 Transfer from system to controller 1 Transfer from controller to system bit 5 = 1 Non-DMA mode bit 4 = 1 Diskette drive controller is busy bits 3-2 = Reserved bit 1 = 1 Drive 1 is busy bit 0 = 1 Drive 0 is busy
03F5h	R / W	Data register for primary diskette drive controller
03F6h	R	Control port for primary diskette drive controller bits 7-4 = Reserved bit 3 = 0 Reduce write current 1 Head select enable bit 2 = 0 Disable diskette drive reset 1 Enable diskette drive reset bit 1 = 0 Disable diskette drive initialization 1 Enable diskette drive initialization bit 0 = Reserved
03F7h	R	Digital input register for primary diskette drive controller bit 7 = 1 Diskette drive line change bit 6 = 1 Write gate bit 5 = Head select 3 / reduced write current bit 4 = Head select 2 bit 3 = Head select 1 bit 2 = Head select 0 bit 1 = Drive 1 select bit 0 = Drive 0 select
03F7h	W	Select register for primary diskette data transfer rate bits 7-2 = Reserved bits 1-0 = 00 500 Kbs mode 01 300 Kbs mode 10 250 Kbs mode 11 Reserved
I/O addresses 03F8h - 03FFh are reserved for use with serial port 1. The bit definitions for these addresses also apply to serial ports 2, 3, and 4.		
03F8h	W	Transmitter holding register for serial port 1 - Contains the character to be sent. Bit 0, the least significant bit, is the first bit sent. bits 7-0 = Data bits 0-7 when the Divisor Latch Access Bit (DLAB) is 0
03F8h	R	Receive buffer register for serial port 1 - Contains the character to be received. Bit 0, the least significant bit, is the first bit received. bits 7-0 = Data bits 0-7 when the Divisor Latch Access Bit (DLAB) is 0

Continued...

I/O Address	Read/Write Status	Description
03F8h	R / W	Baud rate divisor (low byte) - This byte along with the high byte (03F9h) store the data transmission rate divisor. bits 7-0 = Data bits 0-7 when the Divisor Latch Access Bit (DLAB) is 1
03F9h	R / W	Baud rate divisor (high byte) - This byte along with the low byte (03F8h) store the data transmission rate divisor. bits 7-0 = Bits 8-15 when DLAB = 1
03F9h	R / W	Interrupt enable register bits 7-4 = Reserved bit 3 = 1 Modem status interrupt enable bit 2 = 1 Receiver line status interrupt enable bit 1 = 1 Transmitter holding register empty interrupt enable bit 0 = 1 Received data available interrupt enable when DLAB = 0
03FAh	R	Interrupt identification register - serial port 1 bits 7-3 = Reserved bits 2-1 = Identify interrupt with highest priority 00 Modem status interrupt (4th priority) 01 Transmitter holding register empty (3rd priority) 10 Received data available (2nd priority) 11 Receiver line status interrupt (1st priority) bit 0 = 0 Interrupt pending (register contents can be used as a pointer to interrupt service routine) 1 No interrupt pending
03FBh	R / W	Line control register - serial port 1 bit 7 = Divisor Latch Access (DLAB) 0 Access receiver buffer, transmitter holding register, and interrupt enable register 1 Access divisor latch bit 6 = 1 Set break enable. Forces serial output to spacing state and remains there bit 5 = Stick parity bit 4 = Even parity select bit 3 = Parity enable bit 2 = Number of stop bits bit 1 = Word length 00 5-bit word length 01 6-bit word length 10 7-bit word length 11 8-bit word length
03FCh	R / W	Modem control register - serial port 1 bits 7-5 = Reserved bit 4 = 1 Loopback mode for diagnostic testing of serial port. bit 3 = 1 User-defined output 2 bit 2 = 1 User-defined output 1 bit 1 = Force Request To Send active bit 0 = Force Data Terminal Ready active

Continued...

I/O Address	Read/Write Status	Description
03FDh	R	Line status register - serial port 1 bit 7 = Reserved bit 6 = 1 Transmitting shift and holding registers empty bit 5 = 1 Transmitter shift register empty bit 4 = 1 Break interrupt bit 3 = 1 Framing error bit 2 = 1 Overrun error bit 0 = 1 Data ready
03FEh	R	Modem status register - serial port 1 bit 7 = 1 Data Carrier Detect bit 6 = 1 Ring Indicator bit 5 = 1 Data Set Ready bit 4 = 1 Clear To Send bit 3 = 1 Delta Data Carrier bit 2 = 1 Trailing Edge Ring Indicator bit 1 = 1 Delta Data Set Ready bit 0 = 1 Delta Clear To Send
03FFh	R / W	Scratch register - serial port 1 (used for diagnostics)
0A79h	W	PnP Data write register (only for PnP devices)

5.8 BIOS Data Area Definitions

The BIOS Data Area is an area within system RAM that contains information about the system environment. System environment information includes definitions associated with hard disks, diskette drives, keyboard, video, as well as other BIOS functions. This area is created when the system is first powered on. It occupies a 256-byte area from 0400h - 04FFh. The following table lists the contents of the BIOS data area locations in offset order starting from segment address 40:00h.

Location	Description
00h - 07h	I/O addresses for up to 4 serial ports
08h - 0Dh	I/O addresses for up to 3 parallel ports
0Eh - 0Fh	Segment address of extended data address
10h - 11h	Equipment list bits 15-14 = Number of parallel printer adapters 00 = Not installed 01 = One 10 = Two 11 = Three bits 13-12 = Reserved bits 11-9 = Number of serial adapters 00 = Not installed 001 = One 010 = Two 011 = Three 100 = Four bit 8 = Reserved bits 7-6 = Number of diskette drives 00 = One drive 01 = Two drives bits 5-4 = Initial video mode 00 = EGA or PGA 01 = 40 x 25 color 10 = 80 x 25 color 11 = 80 x 25 monochrome bit 3 = Reserved bit 2 = (1) Pointing device present bit 1 = (1) Math coprocessor present bit 0 = (1) Diskette drive present
12h	Reserved for port testing by manufacturer bits 7-1 = Reserved bit 0 = (0) Non-test mode (1) Test mode
13h	Memory size in kilobytes - low byte
14h	Memory size in kilobytes - high byte

Continued...

BIOS Data Area Definitions Continued...

Location	Description
15h - 16h	Reserved
17h	Keyboard Shift Qualifier States bit 7 = Insert mode bit 6 = CAPS lock bit 5 = Numlock bit 4 = Scroll Lock bit 3 = Either Alt key bit 2 = Either control key bit 1 = Left Shift key bit 0 = Right shift key 0 = not set / 1 = set
18h	Keyboard Toggle Key States bit 7 = (1) Insert held down bit 6 = (1) CAPS lock held down bit 5 = (1) Num Lock held down bit 4 = (1) Scroll Lock held down bit 3 = (1) Control+Num Lock held down bit 2 = (1) Sys Re held down bit 1 = (1) Left Alt held down bit 0 = (1) Left Control held down
19h	Scratch area for input from Alt key and numeric keypad
1Ah - 1Bh	Pointer to next character in keyboard buffer
1Ch - 1Dh	Pointer to last character in keyboard buffer
1Eh - 3Dh	Keyboard Buffer. Consists of 16 word entries.
3Eh	Diskette Drive Recalibration Flag bit 7 = (1) Diskette hardware interrupt occurred bits 6-4 = Not used bits 3-2 = Reserved bit 1 = (0) Recalibrate drive B bit 0 = (0) Recalibrate drive A

Continued...

BIOS Data Area Definitions Continued...

Location	Description
3Fh	Diskette Drive Motor Status bit 7 = Current operation 0 = Write or Format 1 = Read or Verify bit 6 = Reserved bits 5-4 = Drive Select 00 = Drive A 01 = Drive B bits 3-2 = Reserved 0 = Disable 1 = Enabled bit 1 = Drive B Motor Status 0 = Off 1 = On bit 1 = Drive A Motor Status 0 = Off 1 = On
40h	Diskette Drive Motor Timeout Disk drive motor is powered off when the value via the INT 08h timer interrupt reaches 0.
41h	Diskette Drive Status bit 7 = Drive Ready 0 = Ready 1 = Not ready bit 6 = Seek Error 0 = No error 1 = Error occurred bit 5 = Controller operation 0 = Working 1 = Failed bits 4-0 = Error Codes 00h = No error 01h = Invalid function requested 02h = Address mark not located 03h = Write protect error 04h = Sector not found 06h = Diskette change line active (door opened) 08h = DMA overrun error 09h = Data boundary error 0Ch = Unknown media type 10h = ECC or CRC error 20h = Controller failure 40h = Seek operation failure 80h = Timeout
42h - 48h	Diskette Controller Status Bytes
49h	Video Mode Setting
4Ah - 4Bh	Number of Columns on screen
4Ch - 4Dh	Size of Current Page, in bytes
4Eh - 4Fh	Address of Current Page

Continued...

BIOS Data Area Definitions Continued...

Location	Description
50h - 5Fh	Position of cursor for each video page. Current cursor position is stored two bytes per page. First byte specifies the column, the second byte specifies the row.
60h - 61h	Start and end lines for 6845-compatible cursor type. 60h = starting scan line, 61h = ending scan line.
62h	Current Video Display Page
63h - 64h	6845-compatible I/O port address for current mode 3B4h = Monochrome 3D4h = Color
65h	Register for current mode select
66h	Current palette setting
67 - 6Ah	Address of adapter ROM
6Bh	Last interrupt the occurred
6Ch - 6Dh	Low word of timer count
6Eh - 6Fh	High word of timer count
70h	Timer count for 24-hour rollover flag
71h	Break key flag
72h - 73h	Reset flag 1243h = Soft reset. Memory test is bypassed.
74h	Status of last hard disk operation 00h = No error 01h = Invalid function requested 02h = Address mark not located 03h = Write protect error 04h = Sector not found 05h = Reset failed 08h = DMA overrun error 09h = Data boundary error 0Ah = Bad sector flag selected 0Bh = Bad track detected 0Dh = Invalid number of sectors on format 0Eh = Control data address mark detected 0Fh = DMA arbitration level out of range 10h = ECC or CRC error 11h = Data error corrected by ECC 20h = Controller failure 40h = Seek operation failure 80h = Timeout AAh = Drive not ready BBh = Undefined error occurred CCh = Write fault on selected drive E0h = Status error or error register = 0 FFh = Sense operation failed
75h	Number of hard drives
76h - 77h	Work area for hard disk

Continued...

BIOS Data Area Definitions Continued...

Location	Description
78h - 7Bh	Default parallel port timeout values
7Dh - 7Fh	Default serial port timeout values
80h - 81h	Pointer to start of keyboard buffer
82h - 83h	Pointer to end of keyboard buffer
84h - 88h	Reserved for EGA/VGA BIOS
8Ah	Reserved
8Bh	Diskette drive data transfer rate information bits 7-5 = Data rate on last operation 00 = 500 KBS 01 = 300 KBS 10 = 250 KBS bits 5-4 = Last drive step rate selected bits 3-2 = Data transfer rate at start of operation 00 = 500 KBS 01 = 300 KBS 10 = 250 KBS bits 1-0 = Reserved
8Ch	Copy of hard status register
8Dh	Copy of hard drive error register
8Eh	Hard drive interrupt flag
8Fh	Diskette controller information bit 7 = Reserved bit 6 = (1) Drive confirmed for drive B bit 5 = (1) Drive B is multi-rate bit 4 = (1) Drive B supports line change bit 3 = Reserved bit 2 = (1) Drive determined for drive A bit 1 = (1) Drive B is multi-rate bit 0 = (1) Drive B supports line change
90h - 91h	Media type for drives bits 7-6 = Data transfer rate 00 = 500 KBS 01 = 300 KBS 10 = 250 KBS bit 5 = (1) Double stepping required when 360K diskette inserted into 1.2MB drive bit 4 = (1) Known media is in drive bit 3 = Reserved bits 2-0 = Definitions upon return to user applications 000 = Testing 360K in 360K drive 001 = Testing 360K in 1.2 MB drive 010 = Testing 1.2 MB in 1.2 MB drive 011 = Confirmed 360K in 360K drive 100 = Confirmed 360K in 1.2 MB 101 = Confirmed 1.2 MB in 1.2 MB drive 111 = 720K in 720K drive or 1.44 MB in 1.44 MB drive

Continued...

BIOS Data Area Definitions Continued...

Location	Description
92h - 93h	Scratch area for diskette media. Low byte for drive A, high byte for drive B.
94h - 95h	Current track number for both drives. Low byte for drive A, high byte for drive B.
96h	Keyboard Status bit 7 = (1) Read ID bit 6 = (1) Last code was first ID bit 5 = (1) Force to Num Lock after read ID bit 4 = (1) Enhanced keyboard installed bit 3 = (1) Right ALT key active bit 2 = (1) Right Control key active bit 1 = (1) Last code was E0h bit 0 = (1) Last code was E1h
97h	Keyboard Status bit 7 = (1) Keyboard error bit 6 = (1) Updating LEDs bit 5 = (1) Resend code received bit 4 = (1) Acknowledge received bit 3 = Reserved bit 2 = (1) Caps lock LED state bit 1 = (1) Num lock LED state bit 0 = (1) Scroll lock LED state
98h - 99h	Offset address of user wait flag
9Ah - 9Bh	Segment address of user wait flag
9Ch - 9Dh	Wait count, in microseconds (low word)
9Eh - 9Fh	Wait count, in microseconds (high word)
A0h	Wait active flag bit 7 = (1) Time has elapsed bits 6-1 = Reserved bit 0 = (1) INT 15h, AH = 86h occurred
A1h - A7h	Reserved
A8h - ABh	Pointer to video parameters and overrides
ACh - FFh	Reserved
100h	Print screen status byte

5.8.1 Compatibility Service Table

In order to ensure compatibility with industry-standard memory locations for interrupt service routines and miscellaneous tabular data, the BIOS maintains tables and jump vectors.

Location	Description
FE05Bh	Entry Point for POST
FE2C3h	Entry point for INT 02h (NMI service routine)
FE3FEh	Entry point for INT 13h (Diskette Drive Services)
FE401h	Hard Drive Parameters Table
FE6F1h	Entry point for INT 19h (Bootstrap Loader routine)
FE6F5h	System Configuration Table
FE739h	Entry point for INT 14h (Serial Communications)
FE82Eh	Entry point for INT 16h (Keyboard Services)
FE897h	Entry point for INT 09h (Keyboard Services)
FEC59h	Entry point for INT 13h (Diskette Drive Services)
FEF57h	Entry point for INT 0Eh (Diskette Hardware Interrupt)
FEFC7h	Diskette Drive Parameters Table
FEFD2h	Entry point for INT 17h (Parallel Printer Services)
FF065h	Entry point for INT 10h (CGA Video Services)
FF0A4h	Video Parameter Table (6845 Data Table - CGA)
FF841h	Entry point for INT 12h (Memory Size Service)
FF84Dh	Entry point for INT 11h (Equipment List Service)
FF859h	Entry point for INT 15h (System Services)
Location	Description
FFA6Eh	Video graphics and text mode tables
FFE6Eh	Entry point for INT 1Ah (Time-of-Day Service)
FFEA5h	Entry Point for INT 08h (System Timer Service)
FFEF3h	Vector offset table loaded by POST
FFF53h	Dummy Interrupt routine IRET Instruction
FFF54h	Entry point for INT 05h (Print Screen Service)
FFFF0h	Entry point for Power-on
FFFF5h	BIOS Build Date (in ASCII)
FFFFEh	BIOS ID

6 VGA, LCD

6.1 VGA / LCD controller 69000

69000 High Performance Flat Panel / CRT HiQVideo™ Accelerator with Integrated Memory

- Highly integrated Flat Panel and CRT GUI Accelerator & Multimedia Engine, Palette/DAC, Clock Synthesizer, and integrated frame buffer
- Integrated High performance SDRAM memory. 2MB integrated memory, 83 MHz SDRAM operation
- HiQColor™ Technology implemented with TMED (Temporal Modulated Energy Distribution)
- Hardware Windows Acceleration
- Integrated composite NTSC / PAL Support
- Hardware Multimedia Support
- High-Performance Flat Panel Display resolution and color depth at 3.3V
- 36-bit direct interface to color and monochrome, single drive (SS), and dual drive (DD), STN & TFT panels
- Advanced Power Management features minimize power usage in:
 - Normal operation
 - Standby (Sleep) modes
 - Panel-Off Power-Saving Mode
- VESA Standards supported
- Fully Compatible with IBM® VGA
- Driver Support for Windows 3.1, Windows 95/98, Windows NT3.1/NT4.0

6.2 VGA / LCD BIOS for 69000

VGA BIOS

The 69000 VGA BIOS is an enhanced, high performance BIOS that is used with the 69000 VGA Flat Panel/CRT Controller to provide an integrated Flat panel VGA solution. The BIOS is optimized for 69000 VGA Flat Panel/CRT Controller and provides:

Full compatibility with the IBM VGA BIOS

Support for monochrome LCD, 640x480, 800x600, 1024x768 and 1280x1024 TFT or STN displays.

Optional support for other displays.

Supports VESA BIOS Extensions, including VBE 2.0, VBE/DDC 1.0, and VBE/PM 1.0.

Supports either VESA local bus or PCI bus

Extended BIOS functions which offer easy access to 69000 controller features and capabilities

Support for simultaneous display

44K BIOS supports 8 panels

48K BIOS supports 16 panels

High Performance Integrated Memory

The integrated SDRAM memory can support up to 83MHz operation, thus increasing the available memory bandwidth for the graphics subsystem. The result is support for additional high color / high resolution graphics modes combined with real-time video acceleration. This additional bandwidth also allows more flexibility in the other graphics functions intensely used in Graphics User Interface (GUIs) such as Microsoft™ Windows™.

Versatile Panel Support

The 69000 support a wide variety of monochrome and color Single-Panel, Single-Drive (SS) and Dual-Panel, Dual-Drive (DD), standard and high-resolution, passive STN and active matrix TFT/MIM LCD, and EL panels. With HiQColor™ technology, up to 256 gray scales are supported on passive STN LCDs. Up to 16.7M different colors can be displayed on passive STN LCDs and up to 16.7M colors on 24bit active matrix LCDs.

The 69000 offers a variety of programmable features to optimize display quality. Vertical centering and stretching are provided for handling modes with less than 480 lines on 480-line panels. Horizontal and vertical stretching capabilities are also available for both text and graphics modes for optimal display of VGA text and graphics modes on 800x600, 1024x768 and 1280x1024 panels.

Low Power Consumption

The 69000 uses a variety of advanced power management features to reduce power consumption of the display sub-system and to extend battery life. optimized for 3.3V operation, the 69000 internal logic, bus and panel interfaces operate at 3.3V but can tolerate 5V operation.

Software Compatibility / Flexibility

The 69000 is fully compatible with the VGA standard at both the register and BIOS levels. DIGITAL-LOGIC supply a fully VGA compatible BIOS, end-user utilities and drivers for common application programs.

Acceleration for All Panels and All Mode

The 69000 graphics engine is designed to support high performance graphics and video acceleration for all supported display resolutions, display types, and color modes. There is no compromise in performance operating in 8, 16, or 24 bpp color modes allowing true acceleration while displaying up to 16.7M colors.

6.3 Display modes supported

The 69000 supports the modes which appear in the table below.

Resolution	Color (bpp)	Refresh Rates (Hz)
640x480	8	60, 75, 85
640x480	16	60, 75, 85
640x480	24	60, 75, 85
800x600	8	60, 75, 85
800x600	16	60, 75, 85
800x600	24	60, 75, 85
1024x768	8	60, 75, 85
1024x768	16	60, 75, 85
1280x1024	8	60

6.4 *VGA/LCD BIOS support*

Each LCD display needs a specific adapted VGA-BIOS.
This product is equipped with the CRT standard VGABIOS.

To connect a LCD display to this product, you need to perform the following:

1. Check the FP_LIST.PDF if the LCD BIOS is available.
Get the latest VGA-BIOS at our webpage <http://www.digitallogic.com>

IF THE LCD BIOS IS AVAILABLE:

2. In the FLATPANEL-SUPPORT documentation the connection between the LCD and this product will be described.
3. DOWNLOAD the corresponding LCD-BIOS with the utility DOWN_000.EXE
Go to the section 4.8.2 DOWNLOAD THE VGABIOS in this manual and follow those steps.
4. Restart the system and check the VGA-BIOS header message. The LCD name must be visible for only a short time. The VGABIOS message appears as first info page on the screen.
5. Stop the system, connect the LCD to the system and restart again
6. If on the LCD no image appears, as soon as the monitor begins to show the first text, stop the system immediately, otherwise the LCD will become damaged.
7. Check the LCD connection again.

FOR A NEW LCD TYPE, NOT AVAILABLE NOW:

If the LCD BIOS for your LCD is not available, DIGITAL-LOGIC will adapt the LCD and provide you with one working cable. To initialise this, we need the following points from you:

1. An order to adapt the LCD (for the costs ask your sales contact)
2. Send the LCD panel, a datasheet, a connector to the LCD and the inverter for the backlight

ATTENTION:

DIGITAL-LOGIC AG is never responsible for a damaged LCD display. Even when there are mistakes in the BIOS or in any documentation for the LCD.

6.5 Memory 69000 CRT/TFT panels

Hor. Resol.	Vert. Resol.	Color bpp	Refr. Hz	DCLK Mhz	MEM kByte	Cursor kByte	FB/C kByte	FB/M kByte	Video Input kByte	Total with Video	Total w/o Video
640	480	8	60	25.175	300	4.2	0	0	300	604	304
640	480	8	72	31.500	300	4.2	0	0	300	604	304
640	480	8	75	31.500	300	4.2	0	0	300	604	304
640	480	8	85	36.000	300	4.2	0	0	300	604	304
640	480	16	60	25.175	600	4.2	0	0	300	904	604
640	480	16	72	31.500	600	4.2	0	0	300	904	604
640	480	16	75	31.500	600	4.2	0	0	300	904	604
640	480	16	85	36.000	600	4.2	0	0	300	904	604
640	480	24	60	25.175	900	4.2	0	0	300	1204	904
640	480	24	72	31.500	900	4.2	0	0	300	1204	904
640	480	24	75	31.500	900	4.2	0	0	300	1204	904
640	480	24	85	36.000	900	4.2	0	0	300	1204	904
800	600	8	60	40.000	469	4.2	0	0	300	773	473
800	600	8	72	50.000	469	4.2	0	0	300	773	473
800	600	8	75	49.500	469	4.2	0	0	300	773	473
800	600	8	85	56.250	469	4.2	0	0	300	773	473
800	600	16	60	40.000	938	4.2	0	0	300	1242	942
800	600	16	72	50.000	938	4.2	0	0	300	1242	942
800	600	16	75	49.500	938	4.2	0	0	300	1242	942
800	600	16	85	56.250	938	4.2	0	0	300	1242	942
800	600	24	60	40.000	1406	4.2	0	0	300	1710	1410
800	600	24	72	50.000	1406	4.2	0	0	300	1710	1410
800	600	24	75	49.500	1406	4.2	0	0	300	1710	1410
800	600	24	85	56.250	1406	4.2	0	0	300	1710	1410
1024	768	16	60	65.000	1536	4.2	0	0	300	1840	1540
1024	768	16	70	75.000	1536	4.2	0	0	300	1840	1540
1024	768	16	75	78.750	1536	4.2	0	0	300	1840	1540
1024	768	16	85	94.500	1536	4.2	0	0	300	1840	1540
1024	768	24	60	65.000	2304	4.2	0	0	300	2608	2308
1024	768	24	72	75.000	2304	4.2	0	0	300	2608	2308
1024	768	24	75	78.750	2304	4.2	0	0	300	2608	2308
1024	768	24	85	94.500	2304	4.2	0	0	300	2608	2308
1280	1024	16	60	108.0	2560	4.2	0	0	300	2864	2564
1280	1024	16	70	128.0	2560	4.2	0	0	300	2864	2564
1280	1024	16	75	135.0	2560	4.2	0	0	300	2864	2564
1280	1024	16	85	157.5	2560	4.2	0	0	300	2864	2564
1280	1024	24	60	108.0	3840	4.2	0	0	300	4144!	3844
1280	1024	24	72	128.0	3840	4.2	0	0	300	4144!	3844
1280	1024	24	75	135.0	3840	4.2	0	0	300	4144!	3844
1280	1024	24	85	157.5	3840	4.2	0	0	300	4144!	3844

! Means not possible resolution with the 4Mb Video RAM

6.6 Memory 69000 color STN-DD panels

Hor. Resol.	Vert. Resol.	Color bpp	Refr. Hz	DCLK Mhz	MEM kByte	Cursor kByte	FB/C kByte	FB/M kByte	Video Input kByte	Total with Video	Total w/o Video
640	480	8	60	25.175	300	4.2	120	0	300	724	424
640	480	8	72	31.500	300	4.2	120	0	300	724	424
640	480	8	75	31.500	300	4.2	120	0	300	724	424
640	480	8	85	36.000	300	4.2	120	0	300	724	424
640	480	16	60	25.175	600	4.2	120	0	300	1024	724
640	480	16	72	31.500	600	4.2	120	0	300	1024	724
640	480	16	75	31.500	600	4.2	120	0	300	1024	724
640	480	16	85	36.000	600	4.2	120	0	300	1024	724
640	480	24	60	25.175	900	4.2	120	0	300	1324	1024
640	480	24	72	31.500	900	4.2	120	0	300	1324	1024
640	480	24	75	31.500	900	4.2	120	0	300	1324	1024
640	480	24	85	36.000	900	4.2	120	0	300	1324	1024
800	600	8	60	40.000	469	4.2	188	0	300	960	660
800	600	8	72	50.000	469	4.2	188	0	300	960	660
800	600	8	75	49.500	469	4.2	188	0	300	960	660
800	600	8	85	56.250	469	4.2	188	0	300	960	660
800	600	16	60	40.000	938	4.2	188	0	300	1429	1129
800	600	16	72	50.000	938	4.2	188	0	300	1429	1129
800	600	16	75	49.500	938	4.2	188	0	300	1429	1129
800	600	16	85	56.250	938	4.2	188	0	300	1429	1129
800	600	24	60	40.000	1406	4.2	188	0	300	1898	1598
800	600	24	72	50.000	1406	4.2	188	0	300	1898	1598
800	600	24	75	49.500	1406	4.2	188	0	300	1898	1598
800	600	24	85	56.250	1406	4.2	188	0	300	1898	1598
1024	768	16	60	65.000	1536	4.2	307	0	300	2147	1847
1024	768	16	70	75.000	1536	4.2	307	0	300	2147	1847
1024	768	16	75	78.750	1536	4.2	307	0	300	2147	1847
1024	768	16	85	94.500	1536	4.2	307	0	300	2147	1847
1024	768	24	60	65.000	2304	4.2	307	0	300	2915	2615
1024	768	24	72	75.000	2304	4.2	307	0	300	2915	2615
1024	768	24	75	78.750	2304	4.2	307	0	300	2915	2615
1024	768	24	85	94.500	2304	4.2	307	0	300	2915	2615
1280	1024	16	60	108.0	2560	4.2	512	0	300	3376	3676
1280	1024	16	70	128.0	2560	4.2	512	0	300	3376	3676
1280	1024	16	75	135.0	2560	4.2	512	0	300	3376	3676
1280	1024	16	85	157.5	2560	4.2	512	0	300	3376	3676
1280	1024	24	60	108.0	3840	4.2	512	0	300	4656!	4356!
1280	1024	24	72	128.0	3840	4.2	512	0	300	4656!	4356!
1280	1024	24	75	135.0	3840	4.2	512	0	300	4656!	4356!
1280	1024	24	85	157.5	3840	4.2	512	0	300	4656!	4356!

! Means not possible resolution with the 4Mb Video RAM

6.7 *Memory 69000 Mono STN-DD panels*

Hor. Resol.	Vert. Resol.	Color bpp	Refr. Hz	DCLK Mhz	MEM kByte	Cursor kByte	FB/C kByte	FB/M kByte	Video Input kByte	Total with Video	Total w/o Video
640	480	8	60	25.175	300	4.2	0	38	300	642	342
640	480	8	72	31.500	300	4.2	0	38	300	642	342
640	480	8	75	31.500	300	4.2	0	38	300	642	342
640	480	8	85	36.000	300	4.2	0	38	300	642	342
640	480	16	60	25.175	600	4.2	0	38	300	942	642
640	480	16	72	31.500	600	4.2	0	38	300	942	642
640	480	16	75	31.500	600	4.2	0	38	300	942	642
640	480	16	85	36.000	600	4.2	0	38	300	942	642
640	480	24	60	25.175	900	4.2	0	38	300	1242	942
640	480	24	72	31.500	900	4.2	0	38	300	1242	942
640	480	24	75	31.500	900	4.2	0	38	300	1242	942
640	480	24	85	36.000	900	4.2	0	38	300	1242	942
800	600	8	60	40.000	469	4.2	0	59	300	832	532
800	600	8	72	50.000	469	4.2	0	59	300	832	532
800	600	8	75	49.500	469	4.2	0	59	300	832	532
800	600	8	85	56.250	469	4.2	0	59	300	832	532
800	600	16	60	40.000	938	4.2	0	59	300	1300	1000
800	600	16	72	50.000	938	4.2	0	59	300	1300	1000
800	600	16	75	49.500	938	4.2	0	59	300	1300	1000
800	600	16	85	56.250	938	4.2	0	59	300	1300	1000
800	600	24	60	40.000	1406	4.2	0	59	300	1769	1469
800	600	24	72	50.000	1406	4.2	0	59	300	1769	1469
800	600	24	75	49.500	1406	4.2	0	59	300	1769	1469
800	600	24	85	56.250	1406	4.2	0	59	300	1769	1469

! Means not possible resolution with the 4Mb Video RAM

7 DESCRIPTION OF THE CONNECTORS

Flat cable

- 44pin IDE is: IDT Terminal for Dual Row (2.00mm grid) and 1.00mm flat cable
- All others are: IDT Terminal for Dual Row 0.1" (2.54mm grid) and 1.27mm flat cable

Connector	Texture	Pin	Remarks
J02	FDD micro	26	FCC micro
J04	COM1 internal ELAN	2x5	2.54mm
J07	LCD / VGA connector	2x20	2.54mm
J22	HDD primary	2x22	2mm
J27	Utility; PS/2- mouse- keyboard; reset; speaker	2x5	2.54mm
J40	PC104 bus	104	2.54mm
J41	COM2 internal ELAN	2x5	2.54mm
J43	LAN	4	2.54mm
J48	Power supply / IrDA	8	2.54mm
J49	COM D SUPER I/O	(2x10)	2.54mm
J50	COM C SUPER I/O	(2x10)	2.54mm
J54	Alternative keyboard	6	2.54mm
J55	DDC (not assembled)	2	2.54mm
J60	Ext. HDD Led	2	2.54mm
B1	Battery Lithium 3.6V	2	
P1	LPT	2x13	2.54mm
U95	SODIMM socket	144	
U96	Compact card holder, typ1	50	
U112	DOC2000 IC socket	2x16	2.54mm
X2	JTAG connector	2x6	2mm
X1	ELAN520 spare (not assembled)	2x15	2mm

J4 Serial Port COM1 (from ELAN520)

Header onboard:	D-SUB connector:	Signal
Pin 1	Pin 1	= DCD
Pin 2	Pin 6	= DSR
Pin 3	Pin 2	= RxD
Pin 4	Pin 7	= RTS
Pin 5	Pin 3	= TxD
Pin 6	Pin 8	= CTS
Pin 7	Pin 4	= DTR
Pin 8	Pin 9	= RI
Pin 9	Pin 5	= GND
Pin10		= VCC

J41 Serial port COM2 (from ELAN520)

Header onboard:	D-SUB connector:	Signal
Pin 1	Pin 1	= DCD
Pin 2	Pin 6	= DSR
Pin 3	Pin 2	= RxD
Pin 4	Pin 7	= RTS
Pin 5	Pin 3	= TxD
Pin 6	Pin 8	= CTS
Pin 7	Pin 4	= DTR
Pin 8	Pin 9	= RI
Pin 9	Pin 5	= GND
Pin10		= VCC

J50 Serial port COM 4 (from 37B787)

Header onboard:	D-SUB connector:	Signal
Pin 1	Pin 1	= DCD
Pin 2	Pin 6	= DSR
Pin 3	Pin 2	= RxD
Pin 4	Pin 7	= RTS
Pin 5	Pin 3	= TxD
Pin 6	Pin 8	= CTS
Pin 7	Pin 4	= DTR
Pin 8	Pin 9	= RI
Pin 9	Pin 5	= GND
Pin10		= VCC

J49 Serial port COM 3 (from 37B787)

Header onboard:	D-SUB connector:	Signal
Pin 11	Pin 1	= DCD
Pin 12	Pin 6	= DSR
Pin 13	Pin 2	= RxD
Pin 14	Pin 7	= RTS
Pin 15	Pin 3	= TxD
Pin 16	Pin 8	= CTS
Pin 17	Pin 4	= DTR
Pin 18	Pin 9	= RI
Pin 19	Pin 5	= GND
Pin 20		= VCC

J2 Floppy Disk Interface- connector (MOLEX 26pin FCC)

FD26: Pin	Signal Name	Function	in/out
1	VCC	+5 volts	
2	IDX	Index Pulse	in
3	VCC	+5 volts	
4	DS2	Drive Select 2	out
5	VCC	+5 volts	
6	DCHG	Disk Change	in
10	M02	Motor On 2	out
12	DIRC	Direction Select	out
14	STEP	Step	out
16	WD	Write Data	out
17	GND	Signal grounds	
18	WE	Write Enable	out
19	GND	Signal grounds	
20	TRKO	Track 0	in
21	GND	Signal grounds	
22	WP	Write Protect	in
23	GND	Signal grounds	
24	RDD	Read Data	in
25	GND	Signal grounds	
26	HS	Head Select	out

J22 IDE interface

Pin	Signal	Pin	Signal
Pin 1	= Reset (active low)	Pin 2	= GND
Pin 3	= D7	Pin 4	= D8
Pin 5	= D6	Pin 6	= D9
Pin 7	= D5	Pin 8	= D10
Pin 9	= D4	Pin 10	= D11
Pin 11	= D3	Pin 12	= D12
Pin 13	= D2	Pin 14	= D13
Pin 15	= D1	Pin 16	= D14
Pin 17	= D0	Pin 18	= D15
Pin 19	= GND	Pin 20	=.(keypin) NC
Pin 21	= NC	Pin 22	= GND
Pin 23	= IOW (active low)	Pin 24	= GND
Pin 25	= IOR (active low)	Pin 26	= GND
Pin 27	= IOCHRDY (active low)	Pin 28	= (ALE / Master-Slave) NC
Pin 29	= NC	Pin 30	= GND
Pin 31	= IRQ	Pin 32	= IOCS16 (active low)
Pin 33	= ADR1	Pin 34	= N.C.
Pin 35	= ADR0	Pin 36	= ADR2
Pin 37	= CS0 (active low)	Pin 38	= CS1 (active low)
Pin 39	= LED (active low)	Pin 40	= GND
Pin 41	= VCC Logic	Pin 42	= VCC Motor
Pin 43	= GND	Pin 44	= NC

P1 Printerport (Centronics)

The printer connector provides an interface for 8 Bit centronics printers.

Header onboard:	D-SUB connector:	Signal
Pin 1	Pin 1	= Strobe
Pin 3	Pin 2	= Data 0
Pin 5	Pin 3	= Data 1
Pin 7	Pin 4	= Data 2
Pin 9	Pin 5	= Data 3
Pin 11	Pin 6	= Data 4
Pin 13	Pin 7	= Data 5
Pin 15	Pin 8	= Data 6
Pin 17	Pin 9	= Data 7
Pin 19	Pin 10	= Acknowledge
Pin 21	Pin 11	= Busy
Pin 23	Pin 12	= paper end
Pin 25	Pin 13	= select
Pin 2	Pin 14	= autofeed
Pin 4	Pin 15	= error
Pin 6	Pin 16	= init printer
Pin 8	Pin 17	= shift in (SI)
Pin 10,12,14,16,18	Pin 18 - 22	= left open
Pin 20,22,24	Pin 23 - 25	= GND

J48 Power supply / IrDA

Pin	Signal	Pin	Signal
Pin 1	= GND	Pin 2	= Vcc suspend (+5V)
Pin 3	= NC	Pin 4	= +12Volt (for LCD backlight)
Pin 5	= Fast IrDA_TX (TTL)	Pin 6	= Fast IrDA_RX (TTL)
Pin 7	= GND	Pin 8	= Vcc suspend (+5V)

Rem:

Fast IrDA is directly connected to the SUPER I/O (TX=pin 82; RX= pin 81). Drivers have to be written by the customer.

J27 Utility- connector, PS/2- mouse- keyboard

Attention: The speaker must be connected to VCC, to have a low inactive current in the speaker !

Pin	Signal	Pin	Signal
Pin 1	= Speaker out	Pin 2	= Ground
Pin 3	= Reset In	Pin 4	= VCC
Pin 5	= Keyboard data	Pin 6	= Keyboard clock
Pin 7	= Ground	Pin 8	= External battery 3.0V (since V2.2) read also chapter 4.5.3
Pin 9	= PS/2 mouse clock	Pin10	= PS/2 mouse data

The Utility connector must be wired to a standard AT-female connector:

Frontside AT-Keyboard (female)

Solderside AT-Keyboard (female)

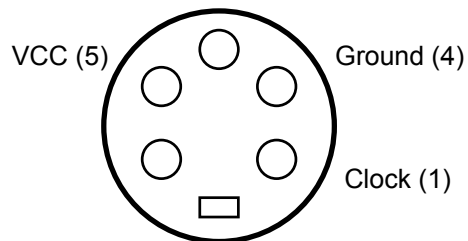
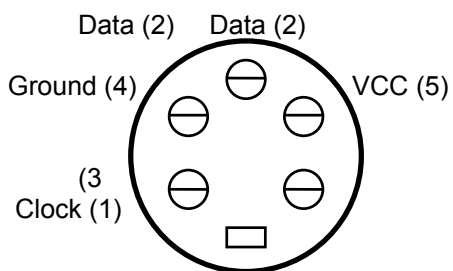

PS/2 Frontside (female)

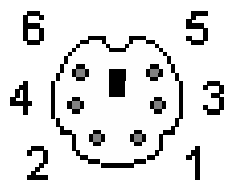

Connector and adapter

	Mini- DIN PS/2 (6 PC)	DIN 41524 (5 PC)	Remarks
Shield	Shield	Shield	KEYBOARD
DATA	1	2	
GND	3	4	
VCC (+5V)	4	5	
CLK	5	1	
	Mini- DIN PS/2 (6 PC)		
VCC (+5V)	4		MOUSE
DATA	1		
GND	3		
CLK	5		

J7L LCD connector**VGA-LCD Interface (flatpanel signals):**

Signals P20-P23 are located on the J7M connector

Pin	Signal	Pin	Signal
1	M / DE Signal	2	FLM
3	P18	4	Line Pulse LP
5	VCC-LCD (1A), Selected by J51	6	GND
7	VEESAVE (5V/1A)	8	Shift Clock
9	VBACKSAVE (12V/1A)	10	P3
11	P2	12	P17
13	P1	14	P16
15	P0	16	P7
17	Contrast resistor pin 1	18	P6
19	Contrast resistor pin 2	20	P5
21	P4	22	P19
23	P8	24	P9
25	P10	26	P11
27	P12	28	P13
29	P14	30	P15

Rem:

- Pin 9 (+12V) will be supplied from J48 (pin 4) or J40 (pin B9).
- Contrast can be controlled via INT15

J7M VGA Monitor (CRT-Signals)

J7 L/M Header			15 pins HiDensity D-SUB	
40 Pin -L	10 Pin -M	Signal	Pin	Signal
Pin 32	Pin 2	VGA red	Pin 1	Red
Pin 34	Pin 4	VGA green	Pin 2	Green
Pin 36	Pin 6	VGA blue	Pin 3	Blue
Pin 38	Pin 8	Horizontal synch	Pin 13	H- synch
Pin 39	Pin 9	Vertical synch	Pin 14	V- synch
			Pin 5 + 11	Bridge
Pin 31	Pin 1	Ground	Pin 5, 6, 7, 8	Ground
Pin 33	Pin 3	LCD-P20		
Pin 35	Pin 5	LCD-P21		
Pin 37	Pin 7	LCD-P22		
Pin 40	Pin 10	LCD-P23		

The VGA-CRT signals from J7 must be wired to a standard VGA HiDensity DSub connector (female):
 The LCD signals must be wired panel specific.

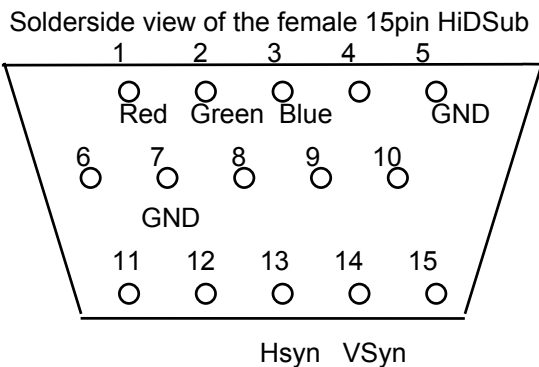

J55 DDC connector (not assembled)

Pin	Signal	Pin	69000
Pin 1	= VSDA	Pin	V3
Pin 2	= VSCL	Pin	U4

J43 10/100 BASE-T Interface connector

J43 Pin *	Signal	RJ-45 Pin	Signal
Pin 1	= TX+	Pin 1	= TX+
Pin 2	= TX-	Pin 2	= TX-
Pin 3	= RX+	Pin 3	= RX+
Pin 4	= RX-	Pin 6	= RX-

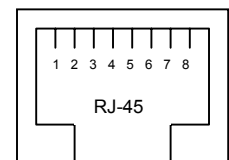

* This signals are ready to connect directly to a RJ-45 connector.

X2 JTAG connector (debugging)

Pin	Signal	Pin	Signal
1	GND	2	VCC
3	TCK	4	CMDACK
5	TMS	6	BREAK
7	TDI	8	STOP
9	TDO	10	TRACE
11	TRST	12	RESETIN

X1 Spare connector (not assembled), for test purposes only

Pin	Signal	Pin	Signal
1	PD0	2	PD1
3	PD2	4	PD3
5	PD4	6	PD5
7	PD6	8	PD7
9	PD8	10	PD9
11	PD10	12	PD11
13	PD12	14	PD13
15	PD14	16	PD15
17	PA0	18	PA1
19	PA2	20	ICEDISABLE
21	PBREQ	22	TV
23	PBGNT	24	PRW
25	TCLK	26	WENABLE
27	WSTR	28	WDENA
29	CLKTEST	30	GND

J60 Ext. HDD Led, (new since V2.2)

Pin	Signal	Pin	Signal
1	Vcc	2	HDD

J40 PC/104 BUS interface

Pin	A:	B:	C:	D:
0			Ground	Ground
1	(IOCHCK) NC	Ground	SBHE	MEMCS16
2	SD7	RESET	LA23	IOCS16
3	SD6	(+5V) NC	LA22	IRQ10
4	SD5	IRQ9	LA21	IRQ11
5	SD4	NC	LA20	IRQ12
6	SD3	DRQ2	LA19	IRQ15
7	SD2	(-12V) NC	LA18	IRQ14
8	SD1	(0WS) NC	LA17	DACK0
9	SD0	+12V	MEMR	DRQ0
10	IOCHRDY	(Ground) NC	MEMW	DACK5
11	AEN	SMEMW	SD8	DRQ5
12	SA19	SMEMR	SD9	DACK6
13	SA18	SIOW	SD10	DRQ6
14	SA17	SIOR	SD11	DACK7
15	SA16	DACK3	SD12	DRQ7
16	SA15	DRQ3	SD13	+5 Volt
17	SA14	DACK1	SD14	(MASTER) NC
18	SA13	DRQ1	SD15	Ground
19	SA12	(REF) **	Ground	Ground
20	SA11	(SYSCLK) *		
21	SA10	IRQ7		
22	SA9	IRQ6		
23	SA8	IRQ5		
24	SA7	IRQ4		
25	SA6	IRQ3		
26	SA5	DACK2		
27	SA4	TC		
28	SA3	ALE		
29	SA2	+5 Volt		
30	SA1	OSC 14MHz		
31	SA0	Ground		
32	Ground	Ground		

* **SYSCLK is 8.25MHz, available since V2.2**

** **REFRESH is pulled up to Vcc with 1 kΩ**

Onboard used signals (not for external use):

IRQ3, IRQ4	COM1 /2
IRQ7	LPT1
IRQ6	FD
IRQ10	HD (BIOS setup depending)
IRQ14	HD
IRQ12	PS/2 Mouse
IRQ13	Coprocessor
TC	FD
DACK2 and DRQ2	FD
DRQ9/10	COM3/COM4

B1 Battery connector

Pin	Signal
Pin 1	Battery 3.6V
Pin 2	Ground

U112 DOC 2000 IC- socket

Pin	Signal	Pin	Signal
1	NC	17	D3
2	A16	18	D4
3	A15	19	D5
4	A12	20	D6
5	A7	21	D7
6	A6	22	CE#
7	A5	23	A10
8	A4	24	OE#
9	A3	25	A11
10	A2	26	A9
11	A1	27	A8
12	A0	28	A13
13	D0	29	A14
14	D1	30	NC
15	D2	31	WE#
16	GND	32	VCC

U96 Compact card holder, typ1

Pin	Signal
Pin 01	= GND
Pin 02	= D3
Pin 03	= D4
Pin 04	= D5
Pin 05	= D6
Pin 06	= D7
Pin 07	= CS0 (active low)
Pin 08	= (A10) NC
Pin 09	= GND
Pin 10	= (A9) NC
Pin 11	= (A8) NC
Pin 12	= (A7) NC
Pin 13	= Vcc
Pin 14	= (A6) NC
Pin 15	= (A5) NC
Pin 16	= (A4) NC
Pin 17	= (A3) NC
Pin 18	= ADR2
Pin 19	= ADR1
Pin 20	= ADR0
Pin 21	= D0
Pin 22	= D1
Pin 23	= D2
Pin 24	= IOCS16 (active low)
Pin 25	= (CD2) NC
Pin 26	= (CD1) NC
Pin 27	= D11

Pin	Signal
Pin 28	= D12
Pin 29	= D13
Pin 30	= D14
Pin 31	= D15
Pin 32	= CS1 (active low)
Pin 33	= (Vs1) NC
Pin 34	= IOR (active low)
Pin 35	= IOW (active low)
Pin 36	= Vcc
Pin 37	= IRQ
Pin 38	= Vcc
Pin 39	= CEL
Pin 40	= (VS2) NC
Pin 41	= Reset (active low)
Pin 42	= IOCHRDY (active low)
Pin 43	= (INPACK-) NC
Pin 44	= Vcc
Pin 45	= LED (active low)
Pin 46	= PDIAG
Pin 47	= D8
Pin 48	= D9
Pin 49	= D10
Pin 50	= GND

Pin order
(solder view)

Pin 25	Pin 1
Pin 50	Pin 26

U95 SODIMM (Small Outline- Dual Inline Memory Module), 144pins

Pin	Normal	Description	Pin	Normal	Description
1	VSS	Ground	73	/OE	
2	VSS	Ground	74	n/c	Not connected
3	DQ0	Data 0	75	VSS	Ground
4	DQ32	Data 32	76	VSS	Ground
5	DQ1	Data 1	77	n/c	
6	DQ33	Data 33	78	n/c	
7	DQ2	Data 2	79	n/c	
8	DQ34	Data 34	80	n/c	
9	DQ3	Data 3	81	VCC	+5 VDC
10	DQ35	Data 35	82	VCC	+5 VDC
11	VCC	+5 VDC	83	DQ16	Data 16
12	VCC	+5 VDC	84	DQ48	Data 48
13	DQ4	Data 4	85	DQ17	Data 17
14	DQ36	Data 36	86	DQ49	Data 49
15	DQ5	Data 5	87	DQ18	Data 18
16	DQ37	Data 37	88	DQ50	Data 50
17	DQ6	Data 6	89	DQ19	Data 19
18	DQ38	Data 38	90	DQ51	Data 51
19	DQ7	Data 7	91	VSS	Ground
20	DQ39	Data 39	92	VSS	Ground
21	VSS	Ground	93	DQ20	Data 20
22	VSS	Ground	94	DQ52	Data 52
23	/CAS0	Column Address Strobe 0	95	DQ21	Data 21
24	/CAS4	Column Address Strobe 4	96	DQ53	Data 53
25	/CAS1	Column Address Strobe 1	97	DQ22	Data 22
26	/CAS5	Column Address Strobe 5	98	DQ54	Data 54
27	VCC	+5 VDC	99	DQ23	Data 23
28	VCC	+5 VDC	100	DQ55	Data 55
29	A0	Address 0	101	VCC	+5 VDC
30	A3	Address 3	102	VCC	+5 VDC
31	A1	Address 1	103	A6	Address 6
32	A4	Address 4	104	A7	Address 7
33	A2	Address 2	105	A8	Address 8
34	A5	Address 5	106	A11	Address 11
35	VSS	Ground	107	VSS	Ground
36	VSS	Ground	108	VSS	Ground
37	DQ8	Data 8	109	A9	Address 9
38	DQ40	Data 40	110	A12	Address 12
39	DQ9	Data 9	111	A10	Address 10
40	DQ41	Data 41	112	A13	Address 13
41	DQ10	Data 10	113	VCC	+5 VDC
42	DQ42	Data 42	114	VCC	+5 VDC
43	DQ11	Data 11	115	/CAS2	Column Address Strobe 2
44	DQ43	Data 43	116	/CAS6	Column Address Strobe 6
45	VCC	+5 VDC	117	/CAS3	Column Address Strobe 3
46	VCC	+5 VDC	118	/CAS7	Column Address Strobe 7
47	DQ12	Data 12	119	VSS	Ground
48	DQ44	Data 44	120	/VSS	Ground
49	DQ13	Data 13	121	DQ24	Data 24
50	DQ45	Data 45	122	DQ56	Data 56
51	DQ14	Data 14	123	DQ25	Data 25
52	DQ46	Data 46	124	DQ57	Data 57
53	DQ15	Data 15	125	DQ26	Data 26
54	DQ47	Data 47	126	DQ58	Data 58
55	VSS	Ground	127	DQ27	Data 27
56	VSS	Ground	128	DQ59	Data 59

Pin	Normal	Description	Pin	Normal	Description
57	n/c		129	VCC	+5 VDC
58	n/c		130	VCC	+5 VDC
59	n/c		131	DQ28	Data 28
60	n/c		132	DQ60	Data 60
61	DU	Don't use	133	DQ29	Data 29
62	DU	Don't use	134	DQ61	Data 61
63	VCC	+5 VDC	135	DQ30	Data 30
64	VCC	+5 VDC	136	DQ62	Data 62
65	DU	Don't use	137	DQ31	Data 31
66	DU	Don't use	138	DQ63	Data 63
67	/WE	Read/Write	139	VSS	Ground
68	n/c	Not connected	140	VSS	Ground
69	/RAS0	Row Address Strobe 0	141	SDA	
70	n/c	Not connected	142	SCL	
71	/RAS1	Row Address Strobe 1	143	VCC	+5 VDC
72	n/c	Not connected	144	VCC	+5 VDC

Information taken from "The Hardware Book"

8 JUMPER LOCATIONS ON THE BOARD

Jumper locations on the board

The figure shows the location of all jumper blocks on the MSM586SEN/SEV board. The numbers shown in this figure are silk screened on the board so that the pins can easily be located. This chapter refers to the individual pin for these jumpers. The default jumper settings are indicated with **bold** letters.

Be careful when you change some jumpers. Some jumpers are soldering bridges, you need a miniature soldering station with vacuum pump.

Top side:

Jumper	Texture	open = 1-2	closed = 2-3
J51	Supply LCD port	1-2 = +5V	2-3 = +3.3V
J53	Compact-flash socket select	open = slave	closed = Master
J56	Power supply	internally controlled via POWERON	disabled / direct connected
J57	DOC2000	enabled via BIOS	C800h
J58	VGA BIOS download enabler Read chapter 5.6.2 !	normal (CORE BIOS)	VGA BIOS enabled
J61	VCCSUS control (since V2.2)	enabled	disabled (power from PC104 connector)

Bottom side:

Jumper	Texture	open = 1-2	closed = 2-3
J5	Floppy drive	1-2 = DRV1	2-3 = DRV0
J6	Floppy motor	1-2 = MTR1	2-3 = MTR0

Settings written in bold are defaults!

8.1 Jumpers locations on the MSM586SEN/SEV V2.1/2.2

Top side:

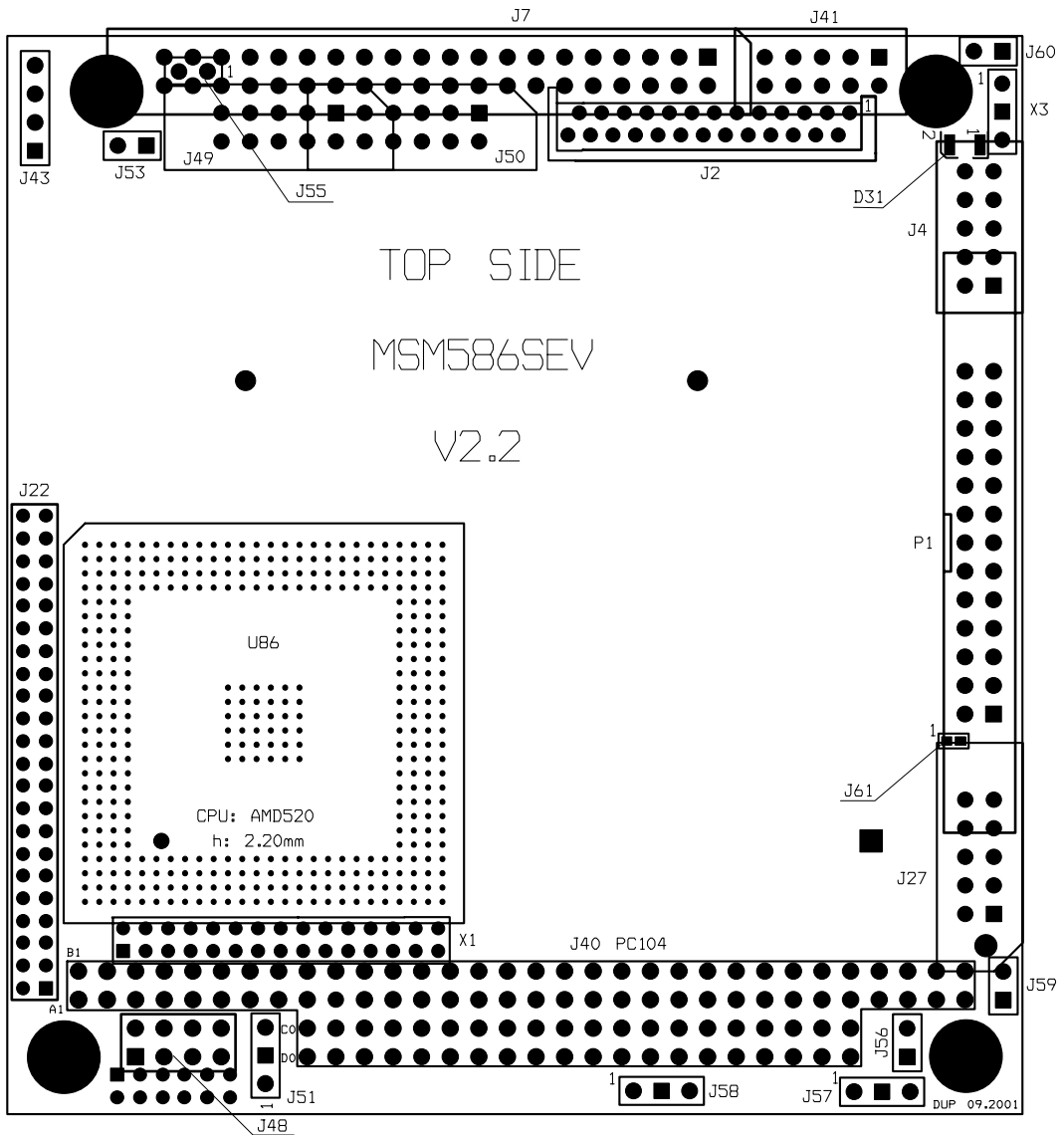

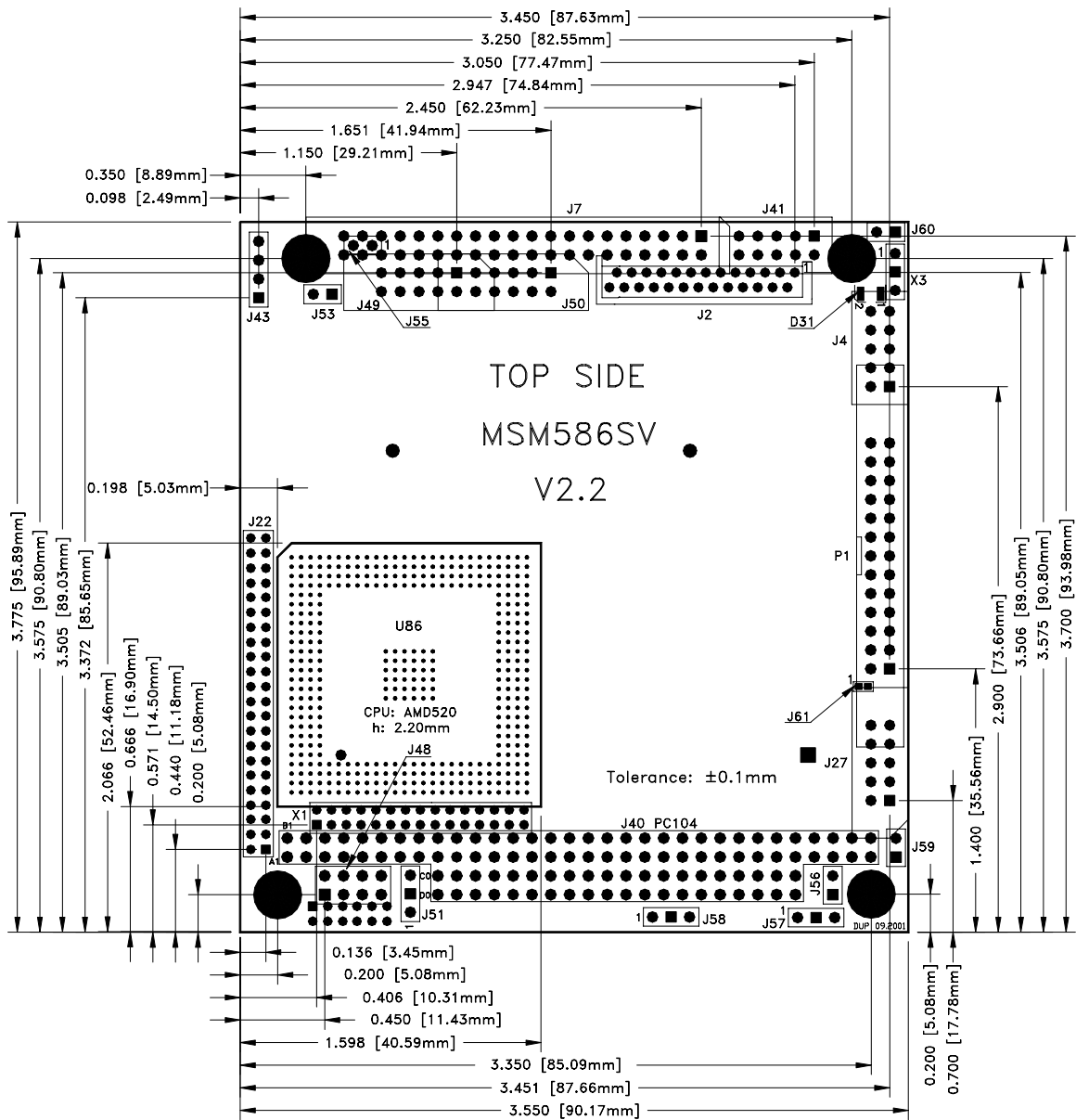

Bottom side:

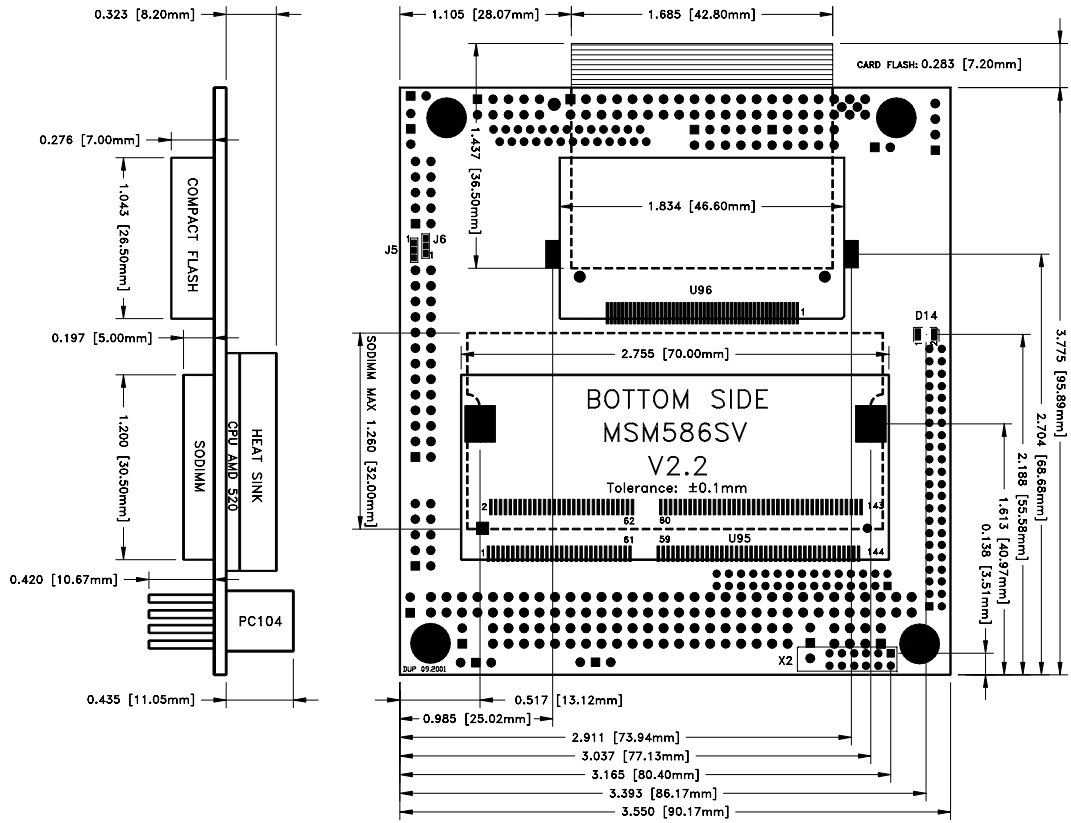

9 LED CRITERIONS:

LED	Color	Function
D14	green	Primary HDD
D32	green	LAN linked
D31	green	LAN active
D30	green	LAN speed

10 CABLE INTERFACE

10.1 The harddisk cable 44pin

IDT Terminal for Dual Row (2.00 mm grid) and 1.00 mm flat cable. 44 pins = 40 pins signal and 4 pins power.

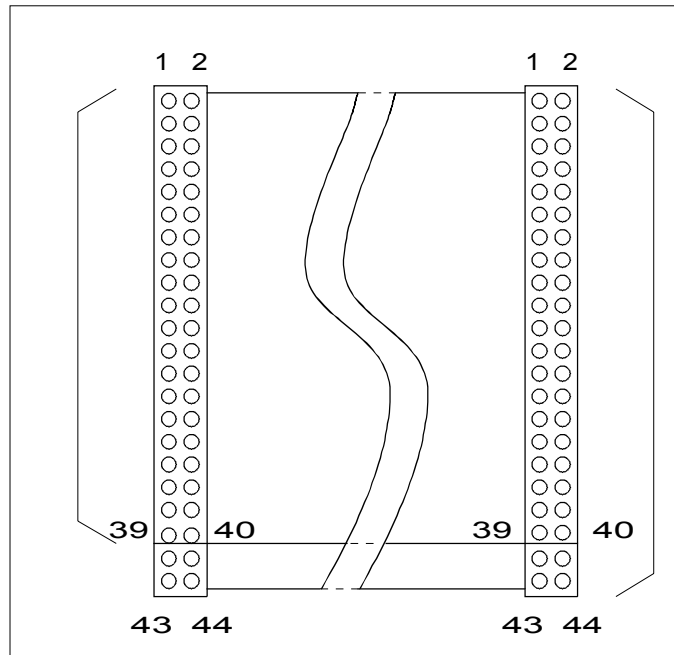

Max. length for the IDE cable is 30 cm.

ATTENTION:

Check the pin 1 marker of the cable and the connector before you power on. Refer to the technical manual of the used drives, because a wrong cable will immediately destroy the drive and/or the MICROSPACE MSM586SEV board. There is no warranty in this case! Without the technical manual you may not connect this type of drive.

The 44pin IDE connector on the drives are normally composed of the 44 pins and 2 open pins and 4 test pins, 50 pins in total. Leave the 4 test pins unconnected .

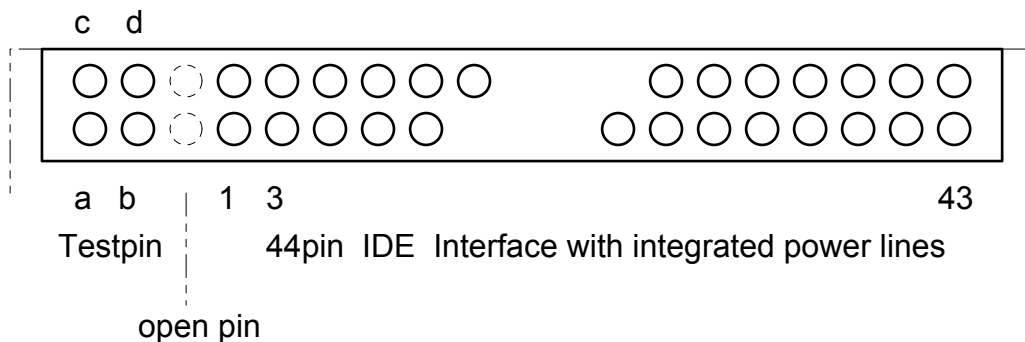

10.2 The COM 1/2/3/4 serial interface cable

DT terminal for dual row 0.1" (2.54 mm grid) and 1.27 mm flat cable.

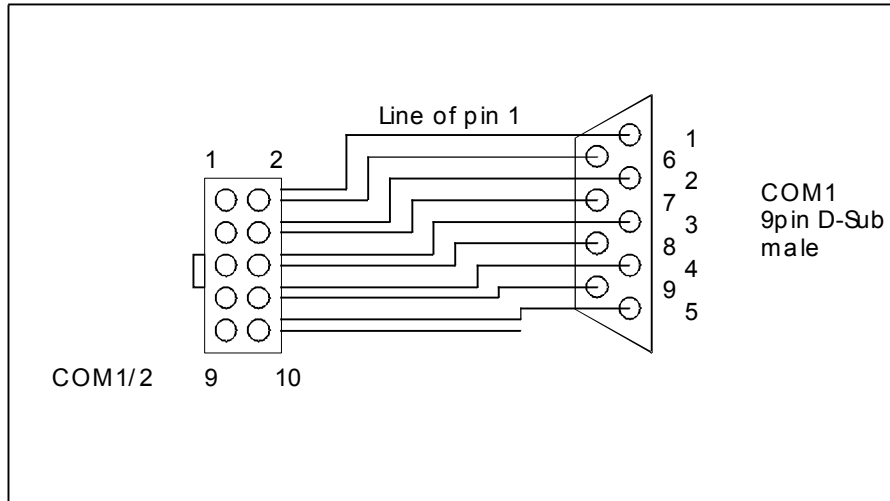

ATTENTION:

- Do not short-circuit these signal lines.
- Never connect any pins either on the same plug or to any other plug on the MICROSPACE MSM586SEV. The +/-10 volts will destroy the MICROSPACE core logic immediately. No warranty in this case!
- Do not overload the output: max. output current converters: 10 mA

10.3 The printer interface cable (P1)

IDT terminal for dual row 0.1" (2.54mm grid) and 1.27 mm flat cable

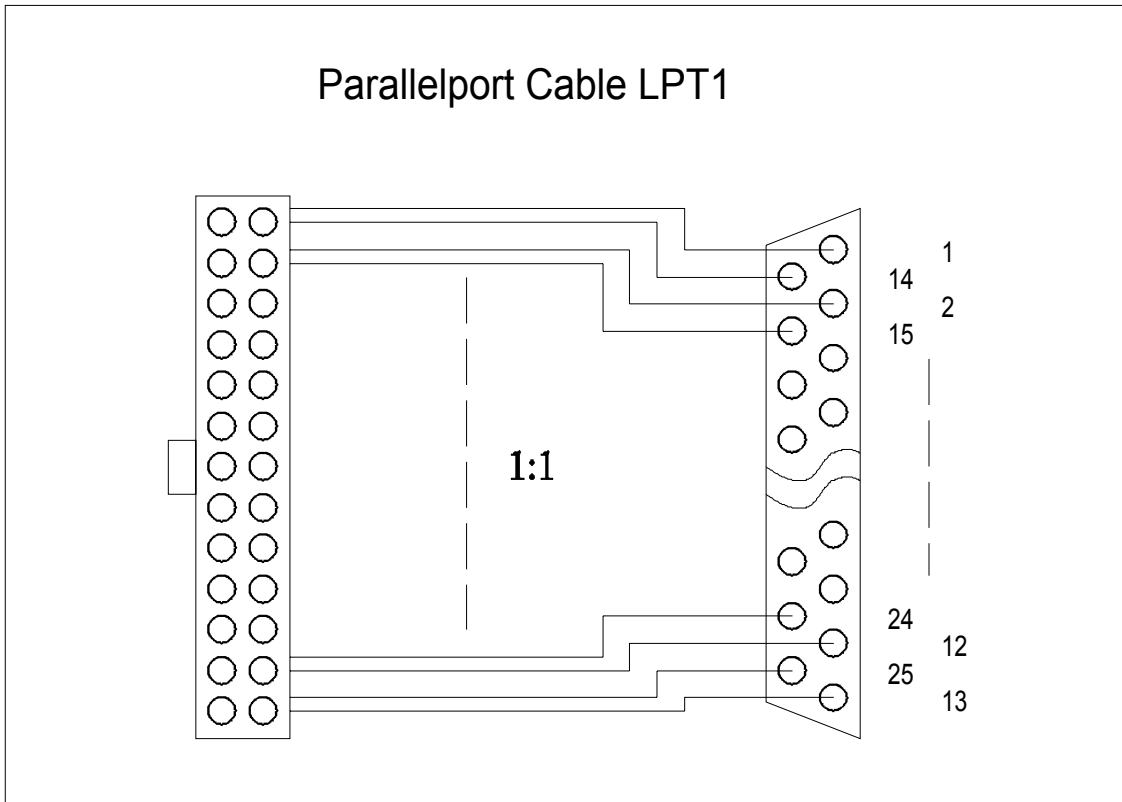

ATTENTION:

- Maximum length of this cable is 6 meters.
- Prevent short-circuits.
- Never apply power to these signals, the MICROSPACE MSM586SEV will be destroyed.

10.4 The Micro Floppy interface cable

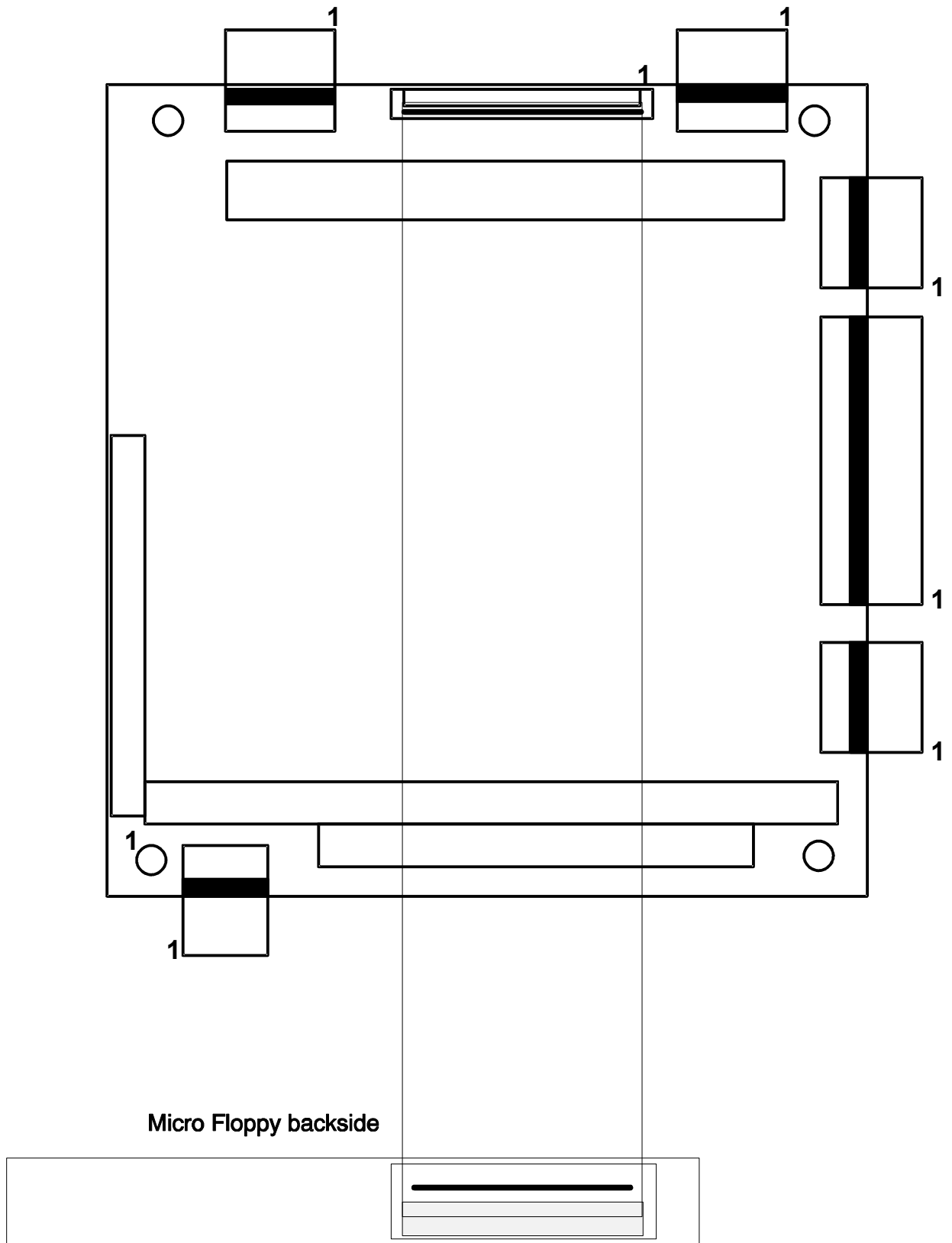

11 REMOTE FUNCTION

Remote works only with the **COM 1** port on the MSM586SEN/SEV.

BIOS default settings are normally as follows:

Internal ELAN A	J4	COM 1
Internal ELAN B	J41	NONE
SUPER I/O C	J50	NONE
SUPER I/O D	J49	COM 2

More details are available in the separate BIOS manual on our CD and homepage !

11.1 Remote Features

FS FORTH-SYSTEME has added its remote package "Embedded Support Kit" to the AMD ÉlanSC520 BIOS. The Embedded Support Kit allows you to control your target machine from a host computer using either a serial or parallel null-modem cable. This is accomplished by transferring all INT10h (video) and INT16h (keyboard) requests to the host machine, executing the command there, and finally returning the results back to the target system. The target system seems to behave just like it would use its own VGA card and keyboard, but in fact it uses the resources of the host computer. Additionally, the target can access the floppy drive and the harddisk of your host PC. These features are of great value when you bring up your own board for the first time. In embedded systems, typical PC components are often left away to save costs. A standard BIOS typically would stop and warn the user that devices are missing. The BIOS has been modified to go on even if there is no keyboard or display adapter. With the "Embedded Support Kit", users can almost work with such machines like they are used to on a standard PC. The BIOS contains support for both serial and parallel transmission.

11.1.1 The Remote Server REMHOST.EXE

The utility REMHOST is started on the host computer. It listens on the serial or parallel port for incoming target requests, executes the commands and sends the output values back.

The user can decide on the host machine in a configuration file, which devices the target system should redirect. By default, the target assumes to redirect video and keyboard services.

The following options are available in the configuration file REMHOST.INI:

```

PORT=1           // COM or LPT port number
LPT *           // use parallel port for transmission
                // comment this for serial port.
FLOPPY          // enable host floppy
FLOPPY=ROMDISK.IMG // use a floppy disk image
WRPROT         // simulate write-protection for remote drives
NOKEYB         // disable host keyboard
NOVIDEO        // disable host video
DUALVIDEO      // use target display and remote video simultaneously

```

Within the configuration file, you can add comments with "///". Instead of using a real floppy drive, you can also generate image files of floppy disks. Access to these image files are much faster than to real floppy disks. Additionally, the image files can be write-protected. So you can build up virtual floppy drives to initially set up the target's file system or to start test tools during production.

Floppy disk images can be produced with the utility FDIMAGE. Type "FDIMAGE /H" to get a list of available options.

Rem:

* not supported, needs a customized BIOS

When video redirection is enabled (option NOVIDEO not active), the BIOS will skip the initialization of both ISA and PCI VGA cards. The BIOS thereby comes up much quicker. Using the keyword DUALVIDEO will enable possible VGA cards as well and display video output on both the real video card and on the remote machine. This allows hardware engineers to debug vga controller problems.

The BIOS will not warn for missing keyboards as soon as remote keyboard is enabled.

You can leave REMHOST by pressing the left SHIFT and STRG keys simultaneously.

11.1.2 Remote enabler

To enable the remote function, one has to make a hardware switch as follows:

- Pin4 (DTR) and pin 9 (RI) have to be bridged on the target PC
- Leave pin 9 unconnected (open) from the host PC

11.1.3 Cable Definition

The wiring of the **serial null-modem cable** is as follows:

PC1 (Host)

PC2 (Target)

Signal Name	Pin Number		Pin Number	Signal Name
DCD	1	--	7, 8	RTS, CTS
RxD	2	--	3	TxD
TxD	3	--	2	RxD
DTR	4	--	6	DSR
GND	5	--	5	GND
DSR	6	--	4	DTR
RTS, CTS	7, 8	--	1	DCD

Optional:

The wiring of the **parallel DOS/Link-Cable** is as follows:

PC1 (Host)**PC2 (Target)**

Signal Name	Pin Number		Pin Number	Signal Name
D0	2	--	15	ERROR#
D1	3	--	13	SLCT
D2	4	--	12	PE
D3	5	--	10	ACK#
D4	6	-- 1	1	BUSY
ERROR#	15	--	2	D0
SLCT	13	--	3	D1
PE	12	--	4	D2
ACK#	10	--	5	D3
BUSY	11	--	6	D4
AFDT#	14	--	14	AFDT#
INIT#	16	--	16	NIT#
SLCTIN#	17	--	17	SLCTIN#
STROBE#	1	--	1	STROBE#
GND	25	--	25	GND

11.1.4 Restrictions

Keep the following restrictions in mind, when using the ESC or writing programs that should also work with redirection:

- WindowsNT denies direct access to hardware I/O ports. If you plan to use REMHOST in a WindowsNT environment, an additional software package is required, that gives access to the specific I/O ports. This software package can be achieved by FS FORTH-SYSTEME.
- Avoid direct writes to video RAM. There is no mechanism to detect and transfer these outputs.
- Since DOS7 of Windows95, standard console output is partially written to the video screen. So you will see only some characters displayed on the host machine, while the rest is displayed on the target's video display.
- Avoid video calls that uses registers other than AX, BX, CX and DX. To speed up video output, only these registers will be transferred. The other registers will be typically used as pointers to data buffers.
- Formatting of remote floppy is not supported.
- Don't rely on „Keyboard Intercept“ INT15/4F. This function is no longer available.
- KEYB.COM is no longer needed on the target machine. Instead, the current keyboard handler of your host computer is automatically used.
- **Don't press Ctrl-Alt-Del, while redirection is active.** This will not reboot your target system, but your host machine !

12 SOFTWARE

On the MICROSPACE Application CD you will find all tools and drivers you will need to work with the card. If you are not sure about the topicality of the software, please visit our homepage at <http://www.digitallogic.com> to get the latest releases !

13 100/10 ETHERNET LAN

Required programs and drivers are located on our CD in the directory `x:\DRIVERS\NETWORK\INTEL\`

13.1 Intel 82559^{ER} Ethernet chip

Create a directory `C:\network` on your harddisk.

Copy the programs and drivers of `x:\DRIVERS\NETWORK\INTEL\82559ER\` onto your HD.

13.1.1 Installation example for MSDOS Novell 4.11

Make sure, that the following directories are in the directory `c:\network`:

- `x:\drivers\network\intel\82559er\drivers`
- `x:\drivers\network\intel\client\dos`

Create a *.bat file in the route `C:\`, with the name "startpro.bat".

The file has the following contents:

```
C:
cd network
cd drivers
ls
e100bodi
ipxodi
cd..
cd dos
vlm
cd \
```

Start the file "startpro.bat".

13.1.2 Driver installation WINDOWS 95

- Copy Intel Pro100+ driver on HD (**x:\drivers\network\intel\82559ER**).
- De-install all networkdrivers under Windows95 in system and software folders and restart Windows. Networkcard Pro10 PCI will be auto-detected and all drivers can be installed (of the copied directory).

13.1.3 Driver installation WINDOWS 98SE

- Update the driver from the Intel® PRO/10+PCI device in the device manager.
- Choose the option "select list with drivers".
- Choose the "Intel 8255xx based Ethernet PCI Adapter(10/100)".
- Go on. If you get a failure report, press ok. If the PC hangs switch off / on the power.
- After reboot you must activate the Intel 8255xx driver in the device manager.

13.1.4 Driver installation WINDOWS NT

Please note, that one has to write the whole directory path, when NT asks for the new driver installation. Windows NT does not search automatically for a new directory.

Installing another driver:

Select the path, where the driver is located, especially where the OEM- inf file is located.

E.g. on our DLAG- CD **x:\drivers\network\intel**

13.1.5 Driver installation WINDOWS 2000

- Update the driver from the Intel® PRO/10+PCI device in the device manager.
- Choose the option "select list with drivers".
- Choose the "Intel 8255xx based Ethernet PCI Adapter(10/100)".
- Go on.

13.1.6 EEPROM update

Do not use this function, if the EEPROM is not corrupted !

To download the datas in the EEPROM, make the following steps:

- copy the folder << **x:\drivers\network\intel\82559er\eeupdate** >> to a floppy disk.
- start MSDOS
- type the following string:

a:\eeupdate -all -device=1209 generic.eep generic.dat

Now the EEPROM is updated again.

13.2 Intel 82559 Ethernet chip

- Create a directory C:\LAN100 on your harddisk.
- Copy the programs and drivers of x:\DRIVERS\NETWORK\INTEL\82559\ onto your HD.

13.2.1 Installation example for MSDOS Novell 4.11

- run "setup.exe" in the directory c:\lan100\...
- choose "install network drivers"
- choose "Novell"
- choose "DOS odi client"
- choose "continue installation"
- the settings in this menu are optional (preferred server (optional); frame type = 802.2)
- press F10
- select a name for the directory of you choice, for example: "c:\network"
- press enter
- choose "modify autoexec.bat"
- exit setup

Change the file "startpro.bat" of c:\network in:

```
C:
cd \network
lsl
e100bodi
ipx.odi
cd dos
vlm
cd \
```

Copy the directory x:\drivers\network\intel\client\dos from our product CD into the directory c:\network\

13.2.2 Driver installation WINDOWS 95

- Copy Intel Pro100+ drivers on HDD (x:\drivers\network\intel\82559).
- De-install all network drivers under Windows95 in system and software folders and restart Windows. Networkcard Pro10 PCI will be auto-detected and all drivers can be installed (of the copied directory).
- Restart Windows and there is a failure message.
- Call up the networkcard-preferences in the devicemanager and update the drivers.
- Choose the Intel 8255x-based PCI Ethernet Adapter (10/100) out of the list.
- Shut down Windows and switch off the power supply unit.
- Boot up again and the network is installed.

13.2.3 Driver installation WINDOWS 98SE

- Update the driver from the Intel® PRO/10+PCI device in the device manager.
- Choose the option "select list with drivers".
- Choose the "Intel 8255xx based Ethernet PCI Adapter(10/100)".
- Go on. If you get a failure report, press ok.
- If the PC hangs, switch off/on the power.
- After reboot, you must activate the Intel 8255xx driver in the device manager.

13.2.4 Driver installation WINDOWS NT

Please note, that one has to write the whole directory path, when NT asks for the new driver installation. Windows NT does not search automatically for a new directory.

Installing another driver:

Select the path, where the driver is located, especially where the OEM- inf file is located.

E.g. on our DLAG- CD `x:\drivers\network\intel`

13.2.5 Driver installation WINDOWS 2000

- Update the driver from the Intel® PRO/10+PCI device in the device manager.
- Choose the option "select list with drivers".
- Choose the "Intel 8255xx based Ethernet PCI Adapter(10/100)" .
- Go on.

13.2.6 EEPROM update

Do not use this function, if the EEPROM is not corrupted !

To download the data into the EEPROM, make the following steps:

- start MSDOS
- change into the directory: `c:\lan100\utility\ee2prom\...`
- type the following string: **`eeupdate -all lan100.eep lan100.dat`**

Now the EEPROM is updated again.

14 INSTALLING THE FLASHDISK DOC2000

On the SSD 36pin socket a DiskOnChip DOC2000 module from M-Systems may be installed. This device is also available at DIGITAL-LOGIC AG.

Operating Systems:

DOS, DL-DOS, RTX-DOS, WIN 3.11, ROM-WIN are working with these drives. All other non DOS compatible systems need a driver.

Give attention to the pin 1 orientation in the 32pin SSD socket.

Latest drivers are available at <http://www.m-sys.com>

14.1 Enabling and formatting of the DiskOnChip-module

Enabling:

No handlings needed, apart of checking the jumper positions in the chapter **JUMPERS**.

Format:

1. Boot up from the standard floppydisk A: or from a harddisk.
2. Enter the tooldisk from M-Systems containing the format tool DFORMAT.EXE
3. Start format utility
The screen should inform about the status of the flashdisk.
4. Enter the DOS-Bootdisk and transfer the bootfiles with SYS A: C:
From this moment, the flashdisk is now the bootable drive C: and if any harddisk is conencted it changes to letter D: and E:

14.2 Compact Flash (CF)

Procedure to prepare a CF to be bootable:

DOS:

1. Check, if CF gets recognized in the BIOS setup
 2. Use FDISK to erase partition
 3. Use FDISK to create a new partition
 4. Use FORMAT to format the CF
 5. Use SYS to copy the system files onto the CF
- You might set the parameters manually (CYL/SEC/HEAD/LBA/etc)
 - Not every CF on the market might get recognized. They might behave differently in starting time.

15 SPECIAL PERIPHERALS, CONFIGURATION

15.1 The special function interface for MICROSPACE computers SFI

All functions are performed by starting the SW-interrupt 15hex with the following arguments:

INT15 FUNCTIONS NOT SUPPORTED YET !

Function:	<u>WRITE TO EEPROM</u>
Number:	E0h
Description:	Writes the Data byte into the addressed User-Memory-Cell from the serial EEPROM. The old value is automatically deleted.
Input Values:	AH = E0h Function Request AL Databyte to store BX Address in the EEPROM (0-1024 Possible) SI 1234h User-Password (otherwise EEP is write-protected) DLAG-Password for access to the DLAG-Memory-Cells
Output Values:	None, all registers are preserved.

Function:	<u>READ FROM EEPROM</u>
Number:	E1h
Description:	Reads the Data byte from the addressed User-Memory-Cell of the serial EEPROM.
Input Values:	AH = E1h Function Request BX Address in the EEPROM (0-1024 Possible) SI 1234h User-Password DLAG-Password for access to the DLAG-Memory-Cells
Output Values:	AL read databyte

Function:	<u>WRITE SERIALNUMBER</u>
Number:	E2h
Description:	Writes the Serialnumber from the serial EEPROM into the addressed DLAG-Memory-Cell. The old value is automatically deleted.
Input Values:	AH = E2h Function Request DX,CX,BX Serialnumber (Binary, not Ascii) SI Password
Output Values:	None, all registers are preserved.

Function:	<u>READ SERIALNUMBER</u>
Number:	E3h
Description:	Reads the serialnumber from the board into the serial EEPROM.
Input Values:	AH = E3h Function Request
Output Values:	DX,CX,BX Serialnumber (Binary, not Ascii)

Function:	<u>WRITE PRODUCTION DATE & RESET DLAG-COUNTERS</u>
Number:	E4h
Description:	Writes the production date into the addressed DLAG-Memory-Cell from the serial EEPROM. The old value is automatically deleted. If the Password is also in DX, the counters will be resetted (=0).
Input Values:	AH = E4h Function Request BX Year (1997 => BH=19, BL=97) CH Month (1..12) CL Day of Month (1..31) SI Password DX Password, if counters should be resetted, otherwise no password.
Output Values:	None, all registers are preserved.

Function:	<u>READ PRODUCTION DATE</u>
Number:	E5h
Description:	Reads the production date from the board in the serial EEPROM.
Input Values:	AH = E5h Function Request
Output Values:	BX Year (1997 => BH=19, BL=97) CH Month (1..12) CL Day of Month (1..31)

Function:	<u>WRITE INFO2 TO THE EEPROM</u>
Number:	F0h (PHOENIX) E8h (AMI)
Description:	Writes the information bytes into the serial EEPROM.
Input Values:	AH = F0h Function Request (PHOENIX) AH = E8h Function Request (AMI) AL Board Type (M= PC/104, E=Euro, W=MSWS, S=Slot, C=Custom) DI CPU Type (1=ELAN310, 2=ELAN400, 3=486SLC, 4=486DX, 5=P5) BX Board Version (Ex: V1.5 => BH=1, BL=5) CX BIOS Version (Ex: V3.0 => CH=3, CL=0) DH Number of 512k Flash DL Number of 512k SRAM SI Password
Output Values:	None, all registers are preserved.

Function:	<u>READ INFO2 FROM THE EEPROM</u>
Number:	E9h
Description:	Reads the information bytes out of the serial EEPROM.
Input Values:	AH = E9h Function Request
Output Values:	AL Board Type (M= PC/104, E=Euro, W=MSWS, S=Slot, C=Custom) DI CPU Type (1=ELAN310, 2=ELAN400, 3=486SLC, 4=486DX, 5=P5) BX Board Version (Ex: V1.5 => BH=1, BL=5) CX BIOS Version (Ex: V3.0 => CH=3, CL=0) DH Number of 512k Flash DL Number of 512k SRAM

Function:	<u>READ INFO3 FROM THE EEPROM</u>
Number:	EAh
Description:	Reads the information bytes out of the serial EEPROM.
Input Values:	AH = EAh Function Request
Output Values:	AX counter of BOOTERRORS counter of SETUP ENTRIES counter of LOW BATTERY ERROR counter of BOOT UP SYSTEM

Function:	SET POWERSAVE
Number:	EDh
Description:	Sets Powersave options.
Input Values:	AH = EDh Function Request AL 00 => LCD Powersave BL Bit 2 LCD-VDD on/off NOT AVAILABLE Bit 1 LCD-VEE on/off NOT AVAILABLE Bit 0 LCD-Backl. on/off NOT AVAILABLE
	01 => HD0 Powersave
AVAILABLE	BL 0 The drive will immediately go to the Standby mode. 1 The drive will immediately go to the active mode. 2 The drive will immediately go to the standby mode. If the sector count registers is zero then the timer will be disabled. If the sector count register is non-zero the timer will be enabled and initialized with the sector count value. 3 The drive will immediately go to the active mode. If the sector count registers is zero then the timer will be disabled. If the sector count register is non-zero the timer will be enabled and initialized with the sector count value. 5 If the drive is in active mode, the sector count registers will be set to 0FFh. If the drive is in, going to, or recovering from the standby mode, the sector count register will be set to 000h. 6 The drive enters the sleep mode. Either a soft- or hardware reset is required to recover from this mode. The drive will then go to the standby mode.
	02 => HD1 Powersave BL Same as HD0 Powersave
Output Values:	None, all registers are preserved

Function:	INFORMATION ABOUT INT15-SUPPORT ON THE BOARD
Number:	EEh
Description:	Gives informations about the supported interrupt 15 functions.
Input Values:	AH = EFh Function Request AL Number of Interrupt, where you need information SI Password, if you want information about a password saved Interrupt
Output Values:	BX Interrupt-Information Word BH Version number of Interrupt (0 = not supported) If there is a Password-saved Interrupt, a zero is shown, if the password is wrong. BL Second-Version number.

NOT AVAILABLE ON THIS BOARD yet !

Function:	WATCHDOG
Number:	EBh
Description:	Enables, strobes and disables the WATCHDOG. After power-up, the Watchdog is always disabled. Once the Watchdog has been enabled, the user application must perform a strobe at least every 800ms, other- wise the watchdog performs a hardware reset.
Input Values:	AH = EBh Function Request AL 00 Disable Watchdog 01..FE Enable Watchdog FF Strobe Watchdog
Output Values:	None, all registers are preserved.

Function:	LCD contrast settings
Number:	
Description:	
Input Values:	AH = ?? Function Request AL = Disable / Enable and strobe ??= Disable of the watchdog ??= Enable ??= send strobe
Output Values:	??

16 BUILDING A SYSTEM

To build up a system based on your board, you should prepare the following equipments:

- A stable power supply of 5V (> 3 ampères), depending on the cpu, memory, etc.
- Assemble CPU with the proper clk- settings and cooling (fan) depending on board.
- If necessary, a 12V power supply for LCD or onboard sound.
- 8 ohm speaker for an executed beep code (if available on the board). One may use a capacity of 1µF connected to VCC depending on the board.
- A micro- floppy disk drive (3,5") with a PC floppy cable (26 pin) or a standard FDD with appropriate cable converter. You need at least one floppy to boot for the first time.
- A harddisk IDE 2,5" or 1,8" with the appropriate cable (44 pin and 2mm grid). Do not use a too long a cable to avoid accessing problem as the IDE controller is may not able to drive the HDD.
- Connect a LCD or a monitor.
- Use an AT-compatible keyboard (5 PC) or (6 PC {PS/2} with an appropriate adapter).
- If desired, connect a mouse to it (COM or PS/2 if usable on the board).
- Connect a battery (Lithium 3V or NiMH 3.6V depending on the board) to store the data in the BIOS.
- If using SODIMM's, please refer to our overview list, which is also on our CD. Cleaning the contacts on the SODIMM and the socket with e.g. pure alcohol is highly recommended to may eliminate memory errors.

The ELAN520 needs special SODIMM's which are available at DLAG !
This information will might change due to normal improvements, please ask DLAG for actual status.

16.1 Starting up the system

Power-up the system and wait for the BIOS to show the BIOS activity on the screen. The BIOS diagnoses the system and displays the size of the memory being tested. Note: you may can not bypass the memory test depending on the BIOS producer.

CMOS-SETUP

If the CMOS configuration is incorrect, the BIOS tells you to enter the setup screen by pressing a key. Select the correct options with the arrow keys and save them.

	INSYDE SOFT
BIOS setup	CTRL- ALT- S
Change values	ARROWS / SPACE
Jump	TAB
Save	ARROWS
Back / exit	ESC

17 **DIAGNOSTICS**

17.1 *Failures and hints*

17.1.1 **Other, so far not identified problems**

A. If the display works:

1. Check if you have a bootable floppy or harddisk
2. Check the CMOS parameter with the setup tools
3. Reset the CMOS RAM with taking off the battery
4. Re-enter the correct values with Setup

B. If no display on the screen is available:

1. Check the power circuitry
2. Check the polarities of the cables
3. Measure the voltage of the power supply under load and offload
4. Measure the current between the supply and the MICROSPACE PC
5. Connect a floppy: does the bezel LED light blink?
6. Does the harddisk spindle motor start?
7. Reset the CMOS-RAM

C. If the error appears again

1. Contact your nearest DIGITAL-LOGIC distributor for Technical Support.
2. Or fill out the support request form (SRF) on the Internet: <http://www.digitallogic.com> / Support

17.2 POST-CODE Description

More details are available in the separate BIOS manual on our CD and homepage !

17.2.1 Boot Loader

00h	DIAG_SYSTEM_INIT	Boot started
01h	DIAG_A20_DISABLE	Disable A20 through A20
02h	DIAG_INIT_CHIPSET	Initialize CS
03h	DIAG_TEST_RAM	Test RAM
04h	DIAG_MOVE_BB_LOADER	Move BL into the RAM
05h	DIAG_EXECUTE_IN_DRAM	Execution in RAM
06h	DIAG_USER_FLASH_CHECK	Check OVERRIDE option
07h	DIAG_SHADOW_BIOS	Shadow System BIOS
08h	DIAG_CHECKSUM_BIOS	Checksum System BIOS ROM
09h	DIAG_NORMAL_BOOT	Proceed with Normal Boot
0Ah	DIAG_CRISIS_BOOT	Proceed with Crisis Boot
51h	DIAG_FATAL_SUPERIO	ALIM5123 not detected
0Fh	DIAG_FATAL_ERROR	Fatal Error

17.2.2 Error Beep codes

F0h	ERROR_BBF_NORAM	No RAM -
F1h	ERROR_BBF_RAMBAD	RAM test failed	... -
02h	ERROR_BBF_NOBIOS	BIOS is not shadowed	.. -
04h	ERROR_BBF_BIOSCS	BIOS Checksum BAD	. -
0Ah	ERROR_BBF_CRISISBAD	No CR code/CR bad	-

17.2.3 System BIOS in Shadow RAM

10H	DEBUG_MISC_RESET	Some Type Of Long Reset
11H	DEBUG_CS_FAST_A20_RESET	Turn off FASTA20 for POST
12H	DEBUG_POST_SIGNAL_POR	Signal Power On Reset
13H	DEBUG_CS_CHIP_INIT	Initialize the Chipset
14H	DEBUG_OEM_ISA_VGA_SEARCH	Search For ISA Bus VGA Adapter
15H	DEBUG_HWIO_SETUP_CTL1	Reset Counter/Timer 1
16H	DEBUG_OEM_SET_CMOS_REGS	user register config through CMOS
17H	DEBUG_CS_MEMORY_SIZE	Size Memory
18H	DEBUG_POST_TEST_RAM	Dispatch To RAM Test
19H	DEBUG_GEN_TEST_ROMS	checksum the ROM
1AH	DEBUG_HWIO_RESET_INTS	Reset PIC's
1BH	DEBUG_VIDEO_VIDEO_INIT	Initialize Video Adapter(s)
1CH	DEBUG_VIDEO_EQUIP_INIT	Initialize Video (6845 Regs)
1DH	DEBUG_VIDEO_COLOR_INIT	Initialize Color Adapter
1EH	DEBUG_VIDEO_BW_INIT	Initialize Monochrome Adapter
1FH	DEBUG_HWIO_TEST_DMA_PAGE	Test 8237A Page Registers
20H	DEBUG_KEYB_SELFTEST_CTLR	Test Keyboard
21H	DEBUG_KEYB_RESET_KEYBOARD	Test Keyboard Controller
22H	DEBUG_POST_CHECK_CMOS_RAM	Check If CMOS Ram Valid
23H	DEBUG_POST_TEST_BATT_CMOS_SUM	Test Battery Fail & CMOS X-SUM
24H	DEBUG_HWIO_TEST_DMA_CTLRS	Test the DMA controllers
25H	DEBUG_HWIO_INIT_8237	Initialize 8237A Controller
26H	DEBUG_POST_INIT_VECS	Initialize Int Vectors
27H	DEBUG_RAM_QUICK_SIZE	RAM Quick Sizing
28H	DEBUG_RAM_PROT_ENTRY_1	Protected mode entered safely

29H	DEBUG_RAM_SIZE_DONE	RAM test completed
2AH	DEBUG_RAM_PROT_EXIT	Protected mode exit successful
2BH	DEBUG_CS_SHADOW_SETUP	Setup Shadow
2CH	DEBUG_VIDEO_EQUIP_INIT_INIT	Going To Initialize Video
2DH	DEBUG_VIDEO_BW_SEARCH	Search For Monochrome Adapter
2EH	DEBUG_VIDEO_COLOR_SEARCH	Search For Color Adapter
2FH	DEBUG_VIDEO_SIGNON	Signon messages displayed
30H	DEBUG_OEM_CONFIG_KBD_CTL	special init of keyboard ctrl
31H	DEBUG_KEYB_PRESENT_TEST	Test If Keyboard Present
32H	DEBUG_KEYB_TEST_IRQ1	Test Keyboard Interrupt
33H	DEBUG_KEYB_TEST_CMD	Test Keyboard Command Byte
34H	DEBUG_RAM_FULL_TEST	TEST, Blank and count all RAM
35H	DEBUG_RAM_PROT_ENTRY_2	Protected mode entered safely (2).
36H	DEBUG_RAM_TEST_DONE	RAM test complete
37H	DEBUG_RAM_PROT_EXIT_2	Protected mode exit successful
38H	DEBUG_KEYB_OUTPUT_PORT	Update OUTPUT port
39H	DEBUG_CS_CACHE_SETUP	Setup Cache Controller
3AH	DEBUG_HWIO_TEST_PERIODIC	Test If 18.2Hz Periodic Working
3BH	DEBUG_GEN_CHECK_RTC	test for RTC ticking
3CH	DEBUG_GEN_INIT_HARD_VECS	initialize the hardware vectors
3DH	DEBUG_MOUSE_INIT	Search and Init the Mouse
3EH	DEBUG_KEYB_SET_LEDS_1	Update NUMLOCK status
3FH	DEBUG_OEM_DEVICE_CONFIG	special init of COMM and LPT ports
40H	DEBUG_CS_CONFIG_PORTS	Configure the COMM and LPT ports
41H	DEBUG_FLOP_INIT	Initialize the floppies
42H	DEBUG_WINI_INIT	Initialize the hard disk
43H	DEBUG_HWIO_ROM_INIT	Initialize option ROMs
44H	DEBUG_OEM_INIT_POWER_MAN	OEM's init of power management
45H	DEBUG_KEYB_SET_LEDS_2	Update NUMLOCK status
46H	DEBUG_HWIO_FIND_80X87	Test For Coprocessor Installed
47H	DEBUG_OEM_LAST_MINUTE_INIT	OEM functions before boot
48H	DEBUG_MISC_LAUNCH_INT19	Dispatch To Op. Sys. Boot
49H	DEBUG_BEGIN_BOOT_CODE	Jump Into Bootstrap Code

17.2.4 Error Beep codes

S-S-S-P-S-S-L-P	The DMA page registers are faulty.
S-S-S-P-S-L-S-P	The refresh circuitry is faulty.
S-S-S-P-S-L-L-P	The ROM checksum is incorrect.
S-S-S-P-L-S-S-P	The CMOS RAM test failed.
S-S-S-P-L-S-L-P	The DMA controller is faulty.
S-S-S-P-L-L-S-P	The interrupt controller failed.
S-S-S-P-L-L-L-P	The 8042 keyboard controller failed.
S-S-L-P-S-S-S-P	No video adapter was found.
S-S-L-P-S-S-L-P	No RAM is installed. No message is displayed.

S=Short, L=Long, P=Pause

18 INDEX

1

10/100 BASE-T Interface	77
100/10 Ethernet LAN	96

A

application notes	16
-------------------	----

B

Battery	30
Battery connector	80
BIOS	33
BIOS CMOS	34
BIOS History	13
BIOS manual	108
BIOS ROM	33
block diagram	9
Building a system	106
BUS	11
bus currents	23
Bus currents	18

C

CMOS	34
CMOS setup	40
CMOS-SETUP	106
Compact card	80
Compact Flash (CF)	100
connectors	71
Coprocessor	10, 26
CORE - BIOS	41
CORE BIOS	41
CRT Displays	66
Current	11

D

debugging	78
DOC 2000	80
DOC2000	100
DRAM	26

E

EEPROM Memory for Setup	33
EMI / EMC	12
Error Beep codes	108, 109
External battery assembling	30

F

Floppy disk	10
Floppy disk interface	28
Floppy Disk Interface	73

Floppy Disk Interface Connector	28
--	----

H

harddisk cable	89
harddisk connected	24

I

I/O map	43
IDE interface	10, 73
Incompatibilities	16
Input Signals	23
interfaces	11
interrupt 15H	101
Interrupt Controllers	29

J

JTAG	78
Jumper locations	84
Jumpers locations	85

K

Keyboard PS/2	27
---------------	----

L

LCD connector	76
LCD contrast	105
LCD controller	65
LED criterions	88
LPT1	27

M

Mechanical Dimensions	14
memory address MAP	43

O

Ordering Codes	16
----------------	----

P

PC/104 BUS Interface	79
POST-CODE	108
power	24
Power supply	74
Power Supply	11
Printer	27
printer interface cable	91
Printerport	74
PS/2	75

R

Remote Function	93
ROM-BIOS	33

S

serial interface cable	90
Serial port	72
Serial Ports	27, 72
<i>SFI</i>	101
SODIMM	82
Speaker	29
<i>Special Function Interface</i>	101
Specifications	10

T

Technical Support	7
Thermoscan	17

U

Utility- connector	74
Utility Connector	75

V

VGA	65
VGA BIOS	42
VGA Monitor	77

W

Watchdog	11, 31
WATCHDOG	105