Welcome.....9

**Using Your VAIO PictureBook Computer ...
11**

Using the Keyboard.....	12
Functions of the keyboard keys	13
Combinations and functions with the Windows key	14
Indicators	16
Indicator lights	17
Combinations and functions with the Fn key	18
Using the MOTION EYE Camera	20
To capture a still image.....	20
To set the image quality and mode of MOTION EYE camera	
22	
Notes on using the MOTION EYE camera	24
Using the Pointing Device.....	26
To replace the pointing device cover.....	27
Using VAIO Action Setup	28
VAIO Action Setup functions.....	28
Using the Jog Dial Control.....	29
Launcher mode	29
Guide mode.....	30
To use the Jog Dial control with Sony software.....	31
To use the Jog Dial control with other software.....	31
Internal timer.....	32
Using Memory Stick Media	33
Types of Memory Stick media.....	33
VisualFlow.....	35

Using PC Cards.....	37
To insert PC card.....	37
To remove a PC Card.....	38
Notes on PC Cards	39
Using the Port Replicator.....	40
To connect a port replicator	40
Using Power Saving Modes.....	41
Normal mode.....	41
Standby mode.....	41
Hibernate mode	41
Notes on power saving modes	42
Connecting a Phone Line	43
How to connect a phone cable	43
Connecting to a LAN	45
To set up your ethernet connection	45

Connecting Peripheral Devices47

Connecting a Floppy Disk Drive	48
To connect the floppy disk drive.....	48
To insert a floppy disk	49
To remove a floppy disk	49
To remove the floppy disk drive when the computer is on.....	49
To carry the floppy disk drive.....	50
Notes on handling floppy disks.....	50
Connecting a PC Card Bus Drive	51
To connect an optical drive.....	51
To insert a disc	52
To remove the drive	53
Notes on CD and DVD discs	54

Connecting an i.LINK Optical Disc Drive	55
To connect an i.LINK optical disc drive.....	55
Notes on using i.LINK optical disc drives.....	57
Connecting a USB Mouse	58
To connect a USB mouse.....	58
Connecting VAIO Computers	59
Connecting with i.LINK	59
Connecting an i.LINK Device.....	60
Connecting an External Display.....	63
To connect a computer display	64
To connect a projector	64
To connect a TV	65
Connecting a USB Printer	67
To connect a printer	67
Connecting an External Microphone.....	68
To connect an external microphone.....	68
To record from a microphone or audio equipment.....	68
To switch the microphone jack functionality	68
To adjust sound volume in the Recording Control window ..	69
To increase the sound of the microphone	69
To adjust sound device volume	69
To set the microphone to echo	71
To modify the MIDI sound.....	71
Connecting External Speakers	73
To connect external speakers.....	73
Notes on using external speakers.....	73
Expanding Your Computer's Capabilities	74
Personal Digital Assistant.....	74
The Wireless LAN Access Point	74
The Wireless LAN PC Card	75

Customizing Your VAIO Computer.....77

Displaying the Sony Notebook Setup Screen	78
Sony Notebook Setup tabs	79
Controlling Power Management	80
To view the Power Management status icons	80
Power Management profiles	81
Power Management commands	84
Conserving battery power	84
Displaying Battery Information	85
Battery icon descriptions.....	85
Displaying detailed battery information	87
Changing the Window Design of Sony Software	88
Selecting the Display Mode	89

Adding Memory91

Precautions and Procedures	92
Typical expansion memory configuration	92
Removing a Memory Module.....	93
Installing a Memory Module	95
Confirming Added Memory Capacity	97

About the Software on Your Computer...99

Overview	100
DVgate application notes	106
Digital video captures	106
Adjusting image resolution	106
Hard disk drive partition	106
Application, Driver, and System Recovery CDs	108

Using Your Recovery CDs.....	109
To use the Application Recovery CD(s).....	109
To use the Driver Recovery CD(s)	109
To use the System Recovery CD(s).....	111
Recovering Microsoft Word	113

Troubleshooting.....115

Troubleshooting Your Computer	116
My computer does not start.	116
My computer starts, but a BIOS error appears.	116
My computer starts, but the message “Operating system not found” appears and Windows does not start.....	117
My computer stops responding or does not shut down. ..	118
The Power Management setting is not responding.	118
The sound of my computer’s fan is too loud.	119
Why does the System Properties dialog box display a slower CPU speed than advertised?	119
Troubleshooting the LCD Screen.....	120
My LCD screen is blank.	120
The image on my connected external display is not centered or sized properly.	120
I cannot simultaneously display movies, DVD video, or the Smart Capture (Finder) window on the LCD display and an external display.....	120
I want to change the video resolution of my display.	120
Troubleshooting the Mouse and Pointing Device ...	121
My mouse does not work.....	121
My pointing device does not work properly.....	121
The pointer does not move (while using the pointing device or mouse).	121
Troubleshooting Drives, PC Cards and Peripheral De-	

vices	123
My floppy disk drive icon doesn't appear even though it is connected.	123
My optical drive is not playing my disc properly.	123
My optical disc drive tray does not open.	124
I cannot use digital video (DV) devices. The message "DV equipment seems to be disconnected or turned off" appears.	124
My PC Card is not working.	124
Troubleshooting i.LINK devices	125
I cannot establish a connection between two VAIO computers when using an i.LINK cable.	125
Troubleshooting Software.....	126
My software program stops responding or crashes.....	126
When I click an application icon, the message "You must insert the application CD into your CD-ROM (DVD-ROM) drive" appears, and the software does not start.....	126
I cannot use the DVgate software.	126
My computer's start-up time seems longer after I have installed AOL. What can I do?.....	126
What software do I use for CD-R/CD-RW software functions?	127
The image does not display properly in Smart Capture Premium.	127
Why doesn't the Bluetooth destination button in the send mode of Smart Capture Premium function?	127
Troubleshooting the Modem.....	128
My modem does not work.	128
My modem connection is slow.	128
Troubleshooting Audio	129
My speakers have no sound.	129
There is noise distortion while listening to music with USB	

speakers or USB headphones.....	129
My microphone does not work.	130
Troubleshooting Memory Stick Media	131
Image files do not open even though I insert Memory Stick media into the slot.	131
Memory Stick media does not work. I cannot access the removable drive.	131

Getting Help **133**

Support Options.....	134
Software Support Information.....	136
Sony Service Center	138

Change text in this variable definition to document title.

Welcome

Congratulations on your purchase of this Sony VAIO® computer, and welcome to the VAIO User Guide.

This User Guide provides detailed information on all aspects of using your new VAIO computer, from keyboard functions to preinstalled software applications.

In the left navigation window, click the topics you want to learn more about, and that information will be displayed in this main window.

Change text in this variable definition to document title.

Using Your VAIO PictureBook Computer

This section describes the following aspects of your new computer:

- Using the Keyboard
- Using the MOTION EYE Camera
- Using the Pointing Device
- Using VAIO Action Setup
- Using the Jog Dial Control
- Using Memory Stick Media
- Using PC Cards
- Using the Port Replicator
- Using Power Saving Modes
- Connecting a Phone Line
- Connecting to a LAN

Using the Keyboard

Your keyboard is very similar to a typewriter's, but your computer keyboard has additional keys that perform specific computer-related tasks.

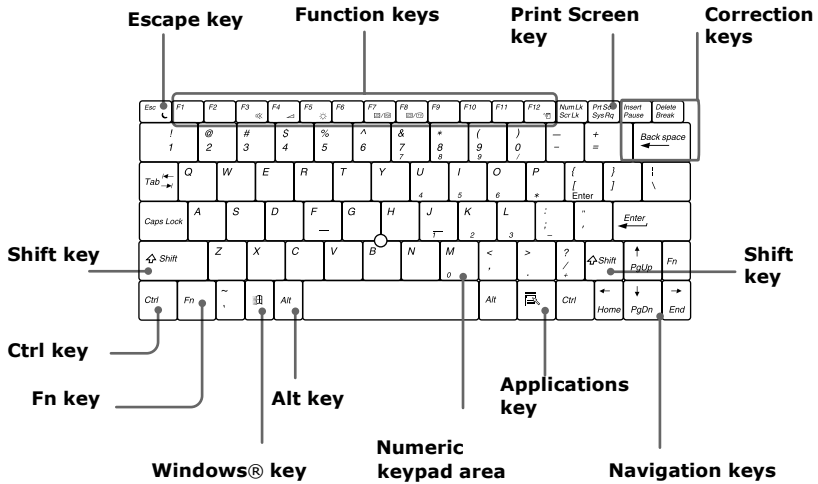

Keyboard





Functions of the keyboard keys







Key	Description
Numeric keypad area	Contains the keys found on a typical calculator. Use the numeric keypad area to type numbers or to perform mathematical calculations such as addition and subtraction. Numbers appear on the front beveled edge of the numeric keys. Note that you must press the Num Lock key to activate the numeric keypad. (When you do so, the Num Lock light will be on.)
Navigation keys	Several keys are devoted to moving the cursor on the screen (the four arrow keys which also function as the Home, End, Page Up, and Page Down keys).
Correction keys	The Insert, Backspace, and Delete keys enable you to make corrections in your documents.
Function keys	The twelve function keys along the top of the keyboard are used to perform designated tasks. For example, in many applications, F1 is the Help key. The task associated with each function key may vary from one application to the next.
Escape key	The Esc (Escape) key is used to cancel commands.
Print Screen key	The Print Screen key takes an electronic snapshot of the screen and places it in the Windows® Clipboard. You can then paste the screen shot into a document and print it.

Change text in this variable definition to document title.

Key	Description
Operator keys (Shift, Ctrl, Alt keys)	Several keys are always used with at least one other key: Ctrl, Alt, and Shift. When held down with another key, the Ctrl (Control) and Alt (Alternate) keys offer another way to give commands. For example, in many applications, instead of choosing the Save command from a menu, you can hold down Ctrl and press the S key (referred to as Ctrl+S). The Shift key operates the same way as on a typewriter; it is used to produce capital letters or special symbols, such as @ and \$.
Windows® key 	The key with the Windows® logo displays the Windows® Start menu; it's the equivalent of clicking the Start button on the taskbar. See “Combinations and functions with the Windows key” for more information.
Fn key	The Fn key is used in combination with other keys to issue commands. The Fn keys at the left and right sides both work the same. See “Combinations and functions with the Fn key” for more information.
Applications key 	The Applications key displays a shortcut menu of context-sensitive choices. Pressing this key is the equivalent of clicking the right mouse button.



Combinations and functions with the Windows key

Combination	Function
 + F1	Displays VAIO® Help and Support Center.
 + Tab	Switches the selected button on the taskbar.
 + E	Displays Windows® Explorer.





Combination	Function
 + F	Displays the Search window to find a file or folder. This is the equivalent of selecting Search from the Start menu.
 + Ctrl + F	Displays the Search Results: Computers window where you can locate other computers. This is the equivalent of selecting Search and then Computers from the Start menu.
 + M	Minimizes all displayed windows (with Num Lock off).
Shift +  + M	Returns all minimized windows to their previous size.
 + R	Displays the Run window. This is the equivalent of selecting Run from the Start menu.
Fn +  + Insert	Displays the System Properties window. This is the equivalent of selecting Control Panel and then System from the Start menu.

Change text in this variable definition to document title.

Indicators

Indicator	Function
Power 	Light is green when the power to the computer is turned on, flashes amber in Standby mode, and turns off when the computer is in Hibernate mode or powered off.
Battery 	Indicates the status of the battery inserted in the computer.
Hard disk 	Lights when data is read from or written to the hard disk drive. Do not enter Standby mode or turn off the computer when this indicator light is on.

Indicator lights

<i>Light</i>	<i>On</i>	<i>Off</i>
Memory Stick® 	Data is read from or written to the Memory Stick media. (Do not enter Standby mode or turn off the computer when this indicator light is on.)	The Memory Stick media is not being accessed.
Num Lock 	The number keys area in the numeric keypad are active.	The alphanumeric character keys in the keypad area are active.
Caps Lock 	The letters appear in uppercase as you type. The Shift key lowers the case of typed letters when Caps Lock is on.	The letters appear in lower case as you type (unless you hold down the Shift key).
Scroll Lock 	The screen scrolls differently. (Exactly how it scrolls depends on the specific application. This function does not work with all applications.)	Information moves across the display normally.

Combinations and functions with the Fn key

 If you switch user identities during a computing session, the Fn+F7 and Fn+F8 key functionality (if available on your computer) will be interrupted. To switch to an external display or monitor, see “Selecting the Display Mode” for more information.

Combinations/ Feature

Functions





Fn+  (ESC)
Standby

Puts the system into Standby mode, a power management state. To return the system to the active state, press any key on your computer.





Fn+  (F3)
Speaker switch

Toggles the built-in speaker off and on.

Fn+  (F4)
Speaker volume

Adjusts the built-in speaker volume.
To increase volume, press Fn+F4, then  or .
To decrease volume, press Fn+F4, then  or .



Fn+  (F5)
Brightness control

Adjusts the brightness of the LCD.
To increase light intensity, press Fn+F5 and then  or .
To decrease light intensity, press Fn+F5 and then  or .

Fn+  (F7)
Switch to the
external display

Toggles between the LCD, external display (connected to the  Monitor port), and both LCD and external display modes.



Fn+  /  (F8)
Switch to the TV

Toggles through LCD display and dual LCD/TV.

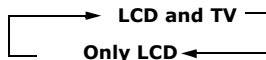

**Combinations/
Feature****Functions**

Fn+  (F12)
Hibernate

Provides for the lowest level of power consumption. When you execute this command, the state of the system and state of the peripheral devices are written to the hard disk and the system power is turned off. To return the system to the original state, press the power button briefly to turn on the power.

Fn+B
Bass Boost

Toggles the bass-boost function off and on. This feature is available only while using headphones.

Fn+ F

Display control. Minimizes and maximizes the LCD screen. If the default display resolution is reduced, this function maximizes the display resolution to fit the screen size. Maximizing the display screen enables you to view the display at a greater resolution.



Some functions are not available until Windows® launches.

Change text in this variable definition to document title.

Using the MOTION EYE Camera

Your computer includes a built-in MOTION EYE™ camera. You can use the camera to shoot still images and record video clips.

To capture a still image

- 1 Press the CAPTURE button to start the Smart Capture Premium application.

CAPTURE Button

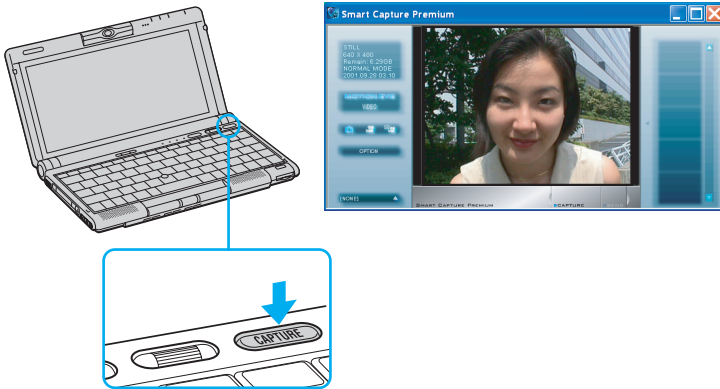

- 2 Select Still Viewer/Long Movie Player/Net Movie Player from the application list.
- 3 Choose Still by clicking the on-screen Capture Mode button. To switch to Motion, click the on-screen Change Capture Mode button. (You can also use Jog Dial control for this function.)

- 4 The Finder window appears. Turn the MOTION EYE camera lens toward the subject you want to photograph.

Turning MOTION EYE

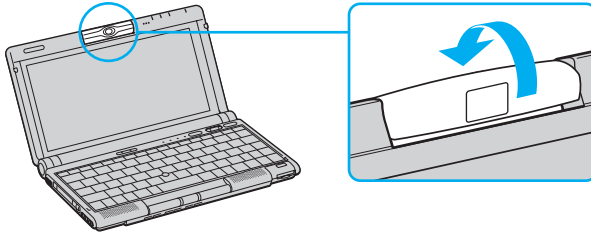

- 5 Adjust the focusing ring.

Adjusting the Focusing Ring

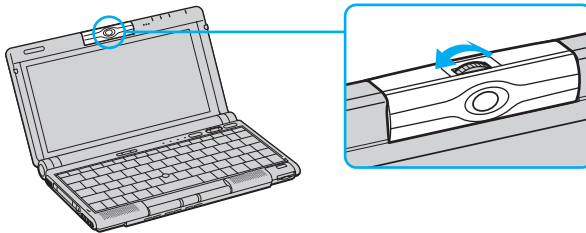

- 6 Half-press the CAPTURE button on the computer. The image remains still for a few seconds. To display another image, release the CAPTURE button and press again.
- 7 Fully press the CAPTURE button. The still viewer window opens and the captured still image appears in the still viewer window.

Change text in this variable definition to document title.

- 8 For more detailed information about the capture software, refer to the online Help for Smart Capture Premium. To access the online help file, click Start on the Windows® taskbar, select All Programs, select Smart Capture Premium, and click Smart Capture Premium Online Help.

If you turn the lens toward you, Smart Capture Premium goes into mirror mode. You can use the mirror mode to take a still image of yourself. A mirror-image appears in the finder window of the display while shooting; after capturing, however, a normal image appears.

 You can capture still images in the following sizes: 640 × 480, 320 × 240, 160 × 120, and 80 × 60 pixels.

Using the self-timer

You can take a still image 10 seconds after clicking the CAPTURE button by using the self-timer.

- 1 Click Still Viewer/Movie Player from the switch applications list.
- 2 Select Still mode.
- 3 Click the Options button. The Still Image Options dialog box appears.
- 4 Click Self-timer capture on the Capturing mode tab.
- 5 Click OK.

After Self-timer capture is complete, the capturing mode changes automatically to single image (Normal Capture).

To display the remaining time before the picture is taken, turn on the capture information display. The capture information display can be turned on and off by selecting Displaying Capture Information from the shortcut menu.

 To stop the self-timer, click the CAPTURE button.

To set the image quality and mode of MOTION EYE camera

You can change the settings of image quality or mode of MOTION EYE camera.

- 1 Click the Start button, then click Control Panel and Printers and Other Hardware.
- 2 Double-click the MOTION EYE™ camera icon. The Camera Control Utility dialog box appears.

 You can also activate the camera control utility using the Jog Dial™ control. The camera control utility is available even while using other software applications that use the MOTION EYE camera.

- 3 Click the Image tab and drag the slider to the left or the right. The level settings increase as the slider is moved to the right, and decrease as it is moved to the left.

Features	Description
Brightness	Adjust the brightness
Contrast	Adjust the contrast of the light part and the dark part
Hue	Adjust the hue of the color
Color	Adjust the coloring
Sharpness	Adjust the sharpness

Change text in this variable definition to document title.

4 Click the Mode tab, and then click the item you want to set.

Features	Description
White balance	Adjust the colors to be more natural. Auto: Adjust automatically to natural colors. Indoor: Suitable for indoor capturing. Outdoor: Suitable for outdoor capturing. Hold: Suspend the proximate settings of the white balance, so that settings do not change automatically.
Shutter speed	Set the shutter speed: Auto: Adjust the shutter speed automatically. $\frac{1}{50}$: This speed is suitable for capturing images under fluorescent light. Hold: Suspend the proximate settings of the shutter speed, so that settings do not change automatically.

The appropriate mode will vary depending on the situation or subject. Switching between outdoor and indoor environments while setting the White Balance to Hold may cause colors to appear incorrectly. To correct color discrepancies, set White Balance to Auto and capture something white, and then wait approximately 10 seconds. The image should now display with the correct color.

5 Click OK.

 Click the Default button, and then click OK to return all settings to the default settings.

Notes on using the MOTION EYE camera

- Do not touch the camera lens, as dirt may accumulate and degrade picture quality.
- Do not point the camera toward the sun.
- You cannot detach the camera.
- Smart Capture Premium is unavailable while other software that uses the built-in camera is in use. Close all software that uses the built-in camera before you use Smart Capture Premium.

- ❑ You cannot transfer still images or video clips from the built-in camera while transferring to connected i.LINK® devices.
- ❑ Take an initial shot before taking a final shot to ensure sound and picture quality.
- ❑ You can adjust the sound quality for different sound environments. Click Start, point to Settings, and then point to Control Panel. Click Sounds and Multimedia and then Audio tab. Click Volume under the Sound Recording category. Adjust the volume level with the microphone slider.
- ❑ Your recording is not guaranteed.
- ❑ If your recording fails due to conditions unfavorable to the camera, the contents of your recording cannot be guaranteed.
- ❑ Clean the lens regularly. Picture quality is adversely affected when the lens is dirty. Use a non-abrasive lens cleaning cloth and approved lens cleaning fluid.

 MOTION EYE™ camera can also be used with the Microsoft® NetMeeting® application. For more information about the Microsoft NetMeeting application, open the Start menu, select All Programs, Accessories, Communications, and then click NetMeeting.

Using the Pointing Device

The pointing device on the keyboard enables you to point to, select, drag, and scroll objects on the screen.

Using the Pointing Device

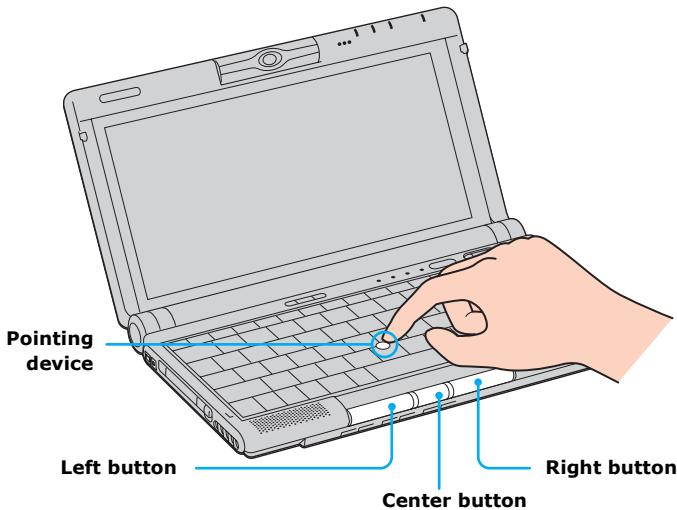

Action	Description
Point	Press the pointing device in a direction to place the pointer on an item or object.
Click	Press the left button once.
Double-click	Press the left button twice.

Action	Description
Right-click	Press the right button once. In many applications, this action displays a shortcut menu of context-sensitive choices.
Drag	Press the pointing device in a direction to place the pointer on an item or object. While holding the left button, press the pointing device in a direction, and then release it at the desired point.
Scroll	Press the pointing device while pressing the center button.

 The scroll function is available only with applications that support a scroll pointing device feature. Pressing the pointing device too hard may damage it.

To replace the pointing device cover

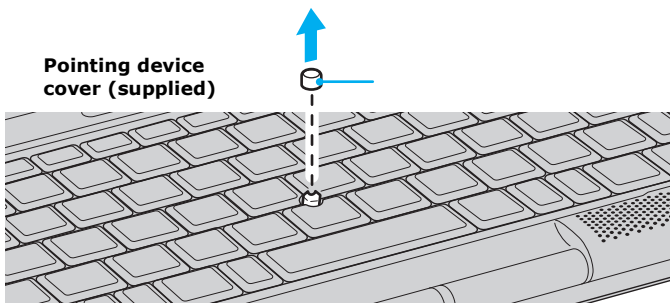

You can take off the pointing device cover and replace it with the additional cover supplied with your computer.

Replacing the Pointing Device Cover



 Make sure the cover is tightly secured to prevent damage to the screen when you close the computer.

Using VAIO Action Setup

VAIO Action Setup manages the settings for your computer's Jog Dial™ control, Memory Stick®  media, and i.LINK® interface. An overview of some of the functions controlled by VAIO Action Setup is provided below. For more information on changing the settings using VAIO Action Setup, right-click the Jog Dial control icon  or , in the task tray and click Help Topics.

VAIO Action Setup functions

- ❑ **Jog Dial** — Changing the Jog Dial setting
- ❑ **Memory Stick** — Changing the Memory Stick media insertion setting
- ❑ **i.LINK** — Changing the i.LINK device connection setting
- ❑ **USB** — Changing the USB device connection setting
- ❑ **Timer** — Setting the timer

Using the Jog Dial Control

Your computer is equipped with a Jog Dial™ control on the top right corner of the unit. The Jog Dial control enables you to open an application, folder, or document from a predefined list by rotating and pressing the Jog Dial control. In addition, when you press the Jog Dial control, you can turn on your computer automatically and start the selected application or document.

Using the Jog Dial Control

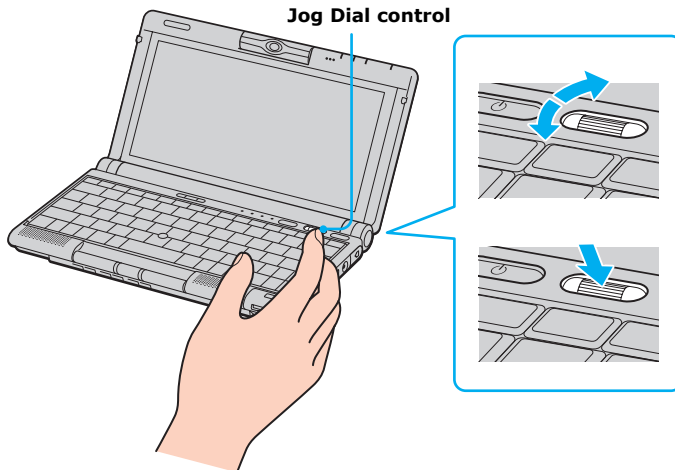

The Jog Dial control window always appears in the display. It is either in the launcher mode or in the guide mode.

For information on how to change the Jog Dial control's settings, right-click the Jog Dial control icon in the task tray and click Help Topics.

Launcher mode

The Jog Dial control window is in launcher mode until a software application is launched or the Jog Dial control window becomes active. When an arrow is displayed next to an item in the Jog Dial control window, you can display a submenu of that item by selecting it and pressing the Jog Dial control button.

Change text in this variable definition to document title.

Using Launcher mode

To use the Jog Dial control, click the Jog Dial control window or the Jog Dial control icon in the task tray. Alternatively, you can press the Jog Dial control while pressing the Ctrl key on the keyboard to switch to the launcher mode.

- 1 Turn the Jog Dial control to select the item you want, then press the Jog Dial control. The window switches to the guide mode, and shows the Jog Dial control's function.

JOG Guide Dialog Box



- 2 Turn or press the Jog Dial control to use the desired function.
- 3 To select another item, switch to the launcher mode and repeat from step 1.

Guide mode

The Jog Dial control window is in the guide mode when software is in use and the software window is active. Depending on the software you are using, you can select items from the displayed list using the Jog Dial control. Some Sony software applications have two modes in List View, Simple Menu, and Full Menu. You can switch the mode by pressing the Shift key while turning the Jog Dial control.

Using guide mode

The Jog Dial control window displays the Jog Dial control's function.

To use the Jog Dial control with Sony software

If Sony software that supports the Jog Dial™ control is active, you can use the Jog Dial's functions that are allocated to that software. For more information on functions allocated to software, see the software application's online Help.

To use the Jog Dial control with other software

If the software you are using does not support the Jog Dial control, you can still perform the following functions:

Action	Description
Maximize Window*	Press the Jog Dial control button to maximize the size of the active window. Press again to return to normal window size.
Minimize Window*	Press the Jog Dial control button to minimize the size of the active window. Press again to return to normal window size.
Finish Window*	Press the Jog Dial control button to close the active application.
Scroll*	Press the Jog Dial control button to begin scrolling within the active window.
Jog Dial Launcher	Press the Jog Dial control button to return the Jog Dial control to Jog Launcher mode.
Menu Bar	Press the Jog Dial control button, then use the Jog Dial control to scroll through the active window's toolbar.

*Some software applications do not support these functions.

Using a dialog box

When a window such as Screen Properties is active, the Dialog box is displayed in the Jog Dial™ window. You can select an item in the window by rotating the Jog Dial control. Pressing the Jog Dial control is the equivalent of pressing Enter.

JOG Guide Dialog Box



Internal timer



You can use the internal timer to start an application at a specific time. The timer, when set, can launch applications even when the computer power is off.

- 1 Rotate or push the Jog Dial™ control, and select VAIO Action Setup in the Jog Dial Launcher window.
- 2 Click Timer from the left menu, then click the clock icon.
- 3 Select either Recommended Settings, Program Files, All Files, or Drag & Drop from the left menu, then select the file or application you wish to launch in the right window.
- 4 Click Next until the One-Time-Only Setting dialog box appears.
- 5 Select the Date and Time and click Next twice, then click Finish and close the VAIO Action Setup window.

Using Memory Stick Media

This new compact, portable, and versatile recording medium has a data capacity exceeding that of a floppy disk. The media is specially designed for exchanging and sharing digital data with compatible products. Because it is removable, the media can be used for external data storage.

Types of Memory Stick media

Two types of Memory Stick® media are available. The first type, MagicGate™  Memory Stick¹ media (hereafter referred as MG Memory Stick media), is provided with copyright protection. (The MG Memory Stick media are colored white.) The second type, simply referred to as Memory Stick²  media, does not have the same copyright protection as MagicGate. (The Memory Stick media are colored purple.)

You can use both media with your computer.

For music, which requires copyright protection, you can only use MG Memory Stick media with your computer. You can also use compatible MagicGate devices to record and play back music when they are connected to your computer.

You can store mixed data on the Memory Stick media. For example, you can copy an image onto MG Memory Stick media that already contains music.

What is MagicGate?

MagicGate technology is copyright protection that consists of authentication and encryption technology. Authentication technology ensures that protected content is only transferred between compliant devices and media. Protected content is recorded and transferred in an encrypted format to prevent unauthorized duplication or playback.



Ensure that the MG Memory Stick media has the MG mark .

1 MagicGate Memory Stick and  are trademarks of Sony Corporation.

2 Memory Stick and  are trademarks of Sony Corporation.

To insert a Memory Stick media

Insert the Memory Stick media into the media slot on the left side of the computer until it clicks into place. When the Memory Stick media is properly in place, Sony's VisualFlow™ software will automatically launch to display the contents of the Memory Stick.

- 1 Insert with the arrow facing toward the Memory Stick® media slot and the label facing up.



Inserting the media in the wrong direction may damage the connector pins.

Hold the Memory Stick media with the arrow pointing in the correct direction and then turn it so the label side is down before inserting into the slot. To avoid damaging the computer or the Memory Stick Media, do not force the Memory Stick media into the slot.

- 2 Carefully insert the Memory Stick media until it clicks into place.

Inserting Memory Stick

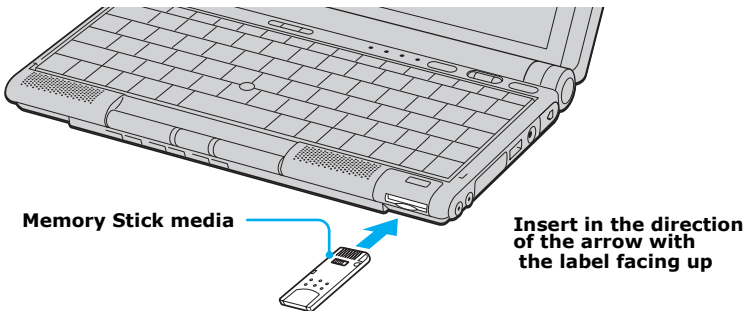

To view the contents of Memory Stick media

To see the contents, do the following:

- 1 Click Start on the Windows® taskbar, and select My Computer.
- 2 Under the heading “Devices with Removable Storage,” click Sony Memory Stick.

To remove a Memory Stick media

Make sure the access light is off. Push the media in toward the computer. When the media ejects, pull it out. When removing the Memory Stick media, be careful as it may eject completely from the slot.

VisualFlow

VisualFlow software is a state-of-the-art Sony multimedia browser designed specifically for Memory Stick media.

To use VisualFlow

- 1 From the Start menu, point to All Programs, and select VisualFlow.

 VAIO Action Setup has been configured to launch VisualFlow by default upon insertion of Memory Stick media. VisualFlow software starts automatically when Memory Stick media is put into the drive.

- 2 Click on an icon in the View section on the main toolbar to select a display layout.
- 3 Click on an icon in the Sort section on the main toolbar to select a sorting method.
- 4 Resting your cursor on the left end of the main toolbar activates the current Memory Stick properties.
- 5 Resting your cursor on the right end of the main toolbar activates a secondary toolbar with more functions.
- 6 Click an image to show a normal view centered on the screen.
 - Double-click an image to show an enlarged view.
- 7 Movie files start playback when the view is enlarged. Click again on movie files to restore the view to normal.

 While an image is enlarged, the Launch toolbar appears on the bottom of the window. Any associated application can be activated from here.

Notes on using Memory Stick media

- ❑ When the media's write-protect tab is set to LOCK, data cannot be recorded or erased.
- ❑ Before using Memory Stick media, you should back up important data.
- ❑ Wait a minimum of 10 seconds after the media finishes reading or writing data before removing it. If the media is removed prematurely, an error message appears, prompting you to continue or exit. Reinsert the media into the slot and press Enter to continue. This enables the media to finish reading or writing data.
- ❑ You can enjoy video clips that you have recorded with compatible Memory Stick digital camcorders.
- ❑ The media slot can accommodate one media at a time.
- ❑ To copy images from a digital video camera via Memory Stick® media, see "Connecting an i.LINK Device" for more information.
- ❑ Only MG™ Memory Stick media can be used with copyright protected data like music.
- ❑ Do not remove the media or turn off the power while the access light is on.
- ❑ Do not use the media in locations that are subject to static electricity or electrical noise.
- ❑ Do not touch the media connector with your finger or metallic objects.
- ❑ Do not attach labels other than the supplied label to a media.
- ❑ Do not bend, drop, or shock the media.
- ❑ Do not disassemble or modify the media.
- ❑ Do not allow the media to get wet.
- ❑ Do not use or store the media in a location that is subject to:
 - ❑ Extremely high temperatures, such as in a car parked in the sun.
 - ❑ Direct sunlight.
 - ❑ High humidity or places with corrosive substances.

To prolong the life of the media, use the supplied storage case. See the instructions supplied with your media for more information on its use.

Using PC Cards

Your computer includes a PC Card slot. PC Cards enable you to connect portable external devices, such as an optical disc drive, or to connect to a network using a PC Network Interface Card (NIC).

 The PC Card slot can accommodate a Type I or Type II PC Card. This slot is compatible with Card Bus. Type III PC Cards are not supported.

To insert PC card

 You do not need to shut down the computer before inserting or removing a PC Card.

- 1 Insert the PC Card into the PC Card slot with the front label facing up. Gently push the PC Card into the slot until it is firmly seated in the port and the release button pops out.

Inserting PC Card

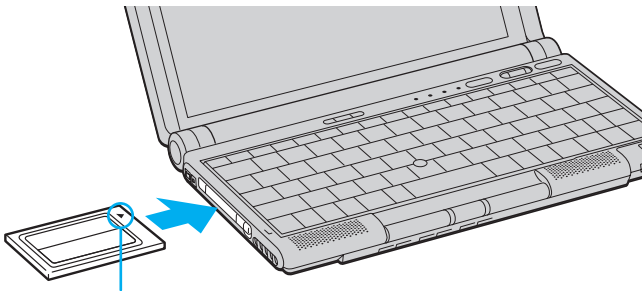

Insert in the direction of the arrow.

- 2 Press the release button down and toward the ventilation slot.

Release Button

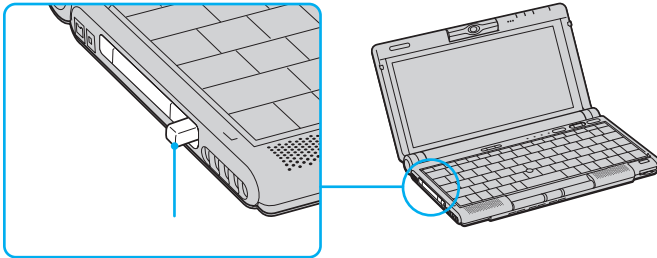

Release button



Do not force a PC Card into the slot. It may damage the connector pins.

When a PC Card is inserted, do not place your computer in a bag or case. Pressure or shock to a PC Card may damage your computer.

Touching the head of the PC Card will not cause damage to the connector pins, but damage can occur if the head of the PC Card is sticking out of the computer while the unit is being transported.

To remove a PC Card

Follow the procedure below when you remove the PC Card while your computer is on. Failure to follow this procedure may result in a malfunction. If your computer is turned off, you do not have to follow these instructions.

- 1 Double-click  in the task tray. The "Safely Remove Hardware" dialog box appears.
- 2 Click Stop. The "Stop a Hardware device" dialog box appears.
- 3 Select the hardware device you wish to remove, and then click OK.
- 4 Click Close to close the "Safely Remove Hardware" dialog box.
- 5 Press the release button toward the computer. The PC Card ejects.
- 6 Gently grasp the PC Card and pull it out.

- 7 Insert the PC Card slot protector into the empty slot.

Notes on PC Cards

- ❑ For some PC Cards, if you alternate between normal power operation and the Standby or Hibernate power management modes while the card is inserted, you may find that a device connected to your system is not recognized. Restart your system to correct the problem.
- ❑ Some PC Cards may require that you disable idle devices when using the PC Card. You can use Sony Notebook Setup to disable devices. See “Displaying the Sony Notebook Setup Screen” for more information.
- ❑ Be sure to use the most recent software driver provided by the PC Card manufacturer.
- ❑ If an exclamation mark (!) appears on the Device Manager tab in the System Properties dialog box, remove the software driver and then reinstall it.
- ❑ You may not be able to use some PC Cards or some functions of the PC Card with this computer. If you have difficulty inserting a card, check that you are orienting the card correctly. See the manual supplied with your PC Card for more information on its use.

Using the Port Replicator

Your computer is supplied with a port replicator, to enable you to connect additional devices. The port replicator is equipped with one each of the following:

- Monitor port
- Ethernet port
- USB port
- AV Out jack
- AV In jack

To connect a port replicator

When connecting the port replicator to the computer, make sure the VAIO® logo on the connector faces up.

- 1 Open the port replicator port cover on the side of the computer.

Connecting the Port Replicator

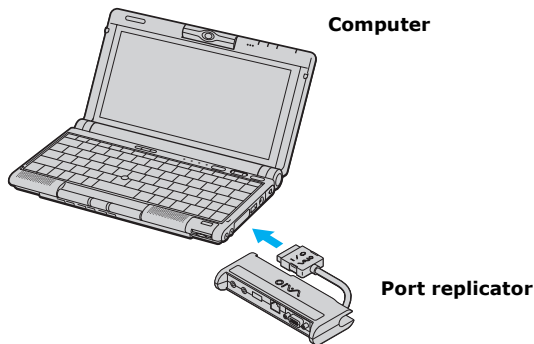

- 2 Insert the port replicator connector gently into the port until it clicks into place. Make sure the VAIO® logo on the connector faces up.
- 3 Connect any compatible peripheral devices to the port replicator.

Using Power Saving Modes

When you use a battery as the source of power for your computer, you can take advantage of power management settings to conserve battery life. In addition to the normal operating mode, which enables you to turn off specific devices, your computer has two distinct power saving modes: Standby and Hibernate. When using battery power, be aware that the computer automatically enters Hibernate mode when the remaining battery charge drops below 5 percent, regardless of the power management setting you select.

 If the battery level falls below 10 percent, you should either attach the AC adapter to recharge the battery or shut down your computer and insert a fully charged battery.

Normal mode

Normal mode is the normal state of your computer when it is in use. The power indicator displays green when your computer is in this mode. To save power, you can turn off a specific device such as the LCD or the hard disk.

Standby mode

In Standby Mode the computer saves the current state of the system in RAM and switches off power to the CPU. The amber power indicator flashes in this mode.

To activate Standby mode

- 1 Press the key combination Fn+Esc. You can also use the PowerPanel™ utility to enter Standby mode.
- 2 Press any key to return to normal mode.

Hibernate mode

In the Hibernate mode, the state of the system is saved on the hard disk drive and power is turned off. The power indicator is off in this mode.

Change text in this variable definition to document title.

To activate Hibernate mode

- 1 To activate Hibernate mode, press the key combination Fn+F12, or press the power button and release it immediately. The “Save to Disk Manager” screen appears and the computer enters Hibernate mode.

 Do not move the computer until its power indicator turns off.

- 2 Press the power button to return to normal mode.

Notes on power saving modes

- When returning from Hibernate mode (by pressing the power button momentarily) the system status stored on the hard disk is erased and the computer starts normally.
- Standby uses more power than Hibernate.
- Standby requires less time than Hibernate to return to normal mode.

Connecting a Phone Line

You need to connect a phone cable (not supplied) to take advantage of online services and the Internet.

 In order to register your VAIO® computer, register your software online, and use Sony Customer Support, you must connect to a phone line.

How to connect a phone cable

- 1 Open the phone line jack cover. The cover opens only to a 45-degree angle.



Use care when opening the phone jack cover. Opening it beyond a 45-degree angle may result in damage to the unit.

Opening Phone Line Jack Cover

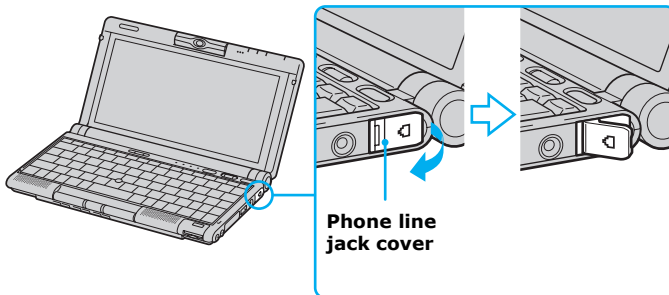



- 2 Plug one end of the phone cable into the jack on the inside of the phone line jack cover. Make sure you insert the phone cable from the rear of the computer and that the modular jack clicks into place.

Change text in this variable definition to document title.

- 3 Plug the other end into the wall jack.

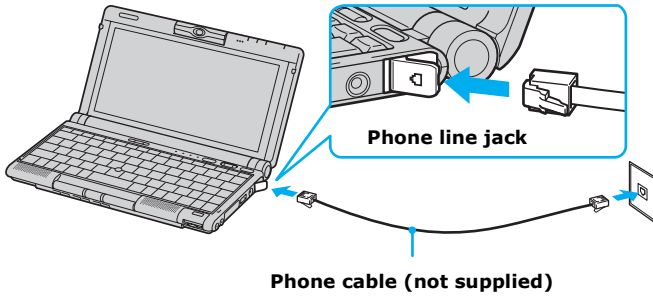
Plugging in Phone Cable



 Your computer does not work with party lines, cannot be connected to a coin-operated telephone, and may not work with multiple phone lines or a private branch exchange (PBX). Some of these connections may result in excess electrical current and could cause a malfunction in the internal modem.

If you connect a phone line coming through a splitter, the modem or connected device may not work properly.

Connecting to a LAN

You can connect your computer to 10BASE-T and 100BASE-TX-type Local Area Networks (LANs) by using the supplied port replicator and its Ethernet port. For the detailed settings and devices needed to connect to the network, ask your network administrator.

Connecting to LAN

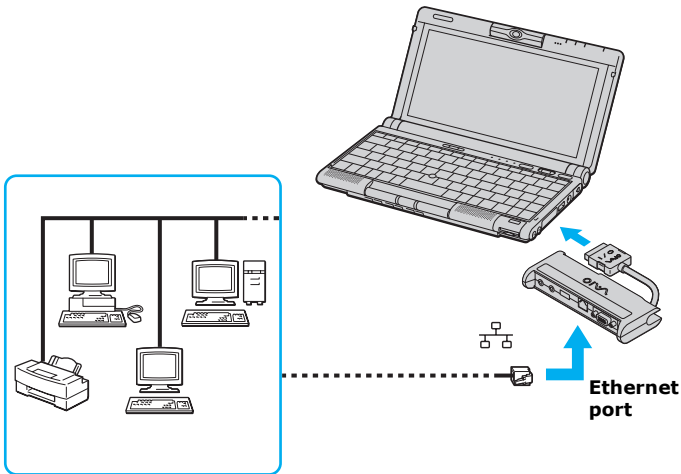

Warning: Only connect 10BASE-T and 100BASE-TX cables to the  Ethernet port. Do not connect any other type of network cable or any telephone line. Connecting cables other than those listed above may result in an electric current overload and could cause a malfunction, excessive heat, or fire in the port. To connect the unit to the network, contact your network administrator.

If you enable Wake on LAN, the power saving mode will be switched to Standby mode.

To set up your ethernet connection

To connect to a network:

Change text in this variable definition to document title.

- 1** Click Start, select My Computer, and click My Network Places under the Other Places header.
- 2** Click “Add a network place” under the Network Tasks header, or click “Set up a home or small office network,” depending on your configuration.
- 3** Depending on your choice, either the The Add Network Place Wizard or Network Setup Wizard is displayed.
- 4** Follow the step-by-step instructions that appear on the screen.

Connecting Peripheral Devices

You can add functionality to your computer by connecting a variety of peripherals, as discussed in the following sections:

- Connecting a Floppy Disk Drive
- Connecting a PC Card Bus Drive
- Connecting an i.LINK Optical Disc Drive
- Connecting a USB Mouse
- Connecting VAIO Computers
- Connecting an i.LINK Device
- Connecting an External Display
- Connecting a USB Printer
- Connecting an External Microphone
- Connecting External Speakers
- Expanding Your Computer's Capabilities

Change text in this variable definition to document title.

Connecting a Floppy Disk Drive

You can connect an optional floppy disk drive (FDD) to the USB Ψ port on your computer.

To connect the floppy disk drive

 You do not need to shut down the computer before connecting or disconnecting the floppy disk drive.

Before removing the FDD, see “To remove the floppy disk drive when the computer is on” for more information.

Plug the USB cable from the floppy disk drive into the USB Ψ port on the computer. The VAIO® logo on the disk drive should be facing up.

Plugging in USB Cable

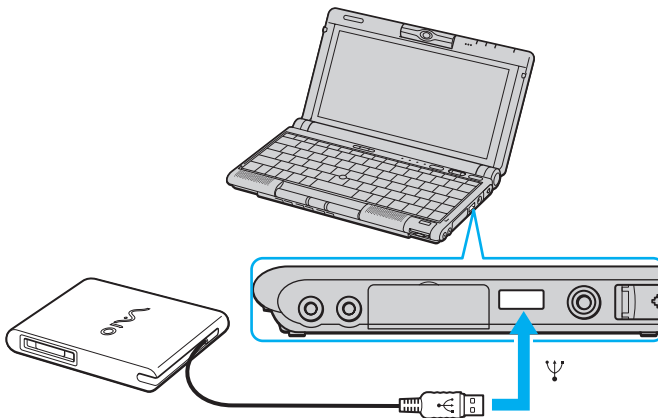

To insert a floppy disk

- 1 Hold the floppy disk with the label side facing up.
- 2 Gently push the floppy disk into the drive until it clicks into place.

Inserting a floppy disk

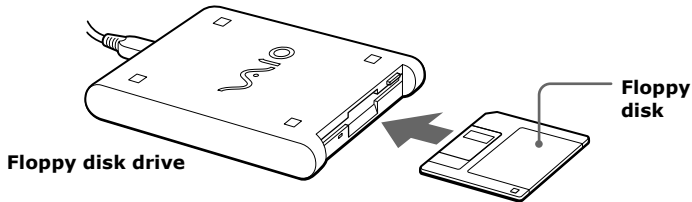

To remove a floppy disk

- ❑ When you finish using the floppy disk, wait until the LED indicator light turns off, and then press the Eject button to remove the disk.

Removing a floppy disk

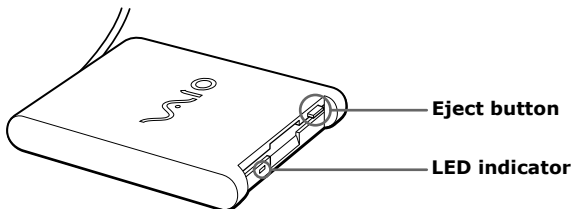

To remove the floppy disk drive when the computer is on

- 1 Double-click  in the task tray. The "Safely Remove Hardware" dialog box appears.
- 2 Click Stop. The "Stop a Hardware device" dialog box appears.
- 3 Select the hardware device you wish to remove, and then click OK.

Change text in this variable definition to document title.

- 4 Click Close to close the "Safely Remove Hardware" dialog box.
- 5 Unplug the floppy disk drive from the computer.

To carry the floppy disk drive

Fold the floppy disk cable into the compartment on the right side.

Notes on handling floppy disks

- Do not open the shutter manually and touch the surface of the disk.
- Keep disks away from magnets.
- Keep disks away from direct sunlight and other heat sources.

Connecting a PC Card Bus Drive

You can use an optional optical drive, such as a Sony DVD-ROM or CD-ROM drive, with your computer. If you use an optional drive when your computer is running on battery power, the battery life will be shorter. The drive draws power from the computer through a PC Card.



If you connect a non-Sony DVD drive to your VAIO® computer, the DVD playback may not function properly. The bundled DVD software must be installed to play a DVD.

For best performance, it is recommended that you use a Sony compatible DVD drive.

To connect an optical drive

Procedures for connecting an optical drive may vary, depending on the specific drive you purchase. See the manual supplied with your optical drive for more information on its installation and use.



You can connect an optical drive while the computer is on. For specific instructions on using your supplied Application, Driver, and System Recovery CDs, see “Using Your Recovery CDs” for more information.

- 1 Remove the PC Card slot protector from the PC Card slot. See “To remove the floppy disk drive when the computer is on” for more information.
- 2 Remove the PC Card from the bottom side of the optical drive.

Removing PC Card

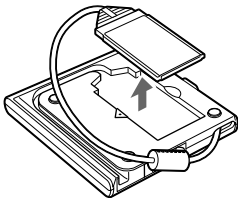

Change text in this variable definition to document title.

- 3 Insert the PC Card into the PC Card slot with the SONY logo facing up. See “Using PC Cards” for details.

Inserting PC Card

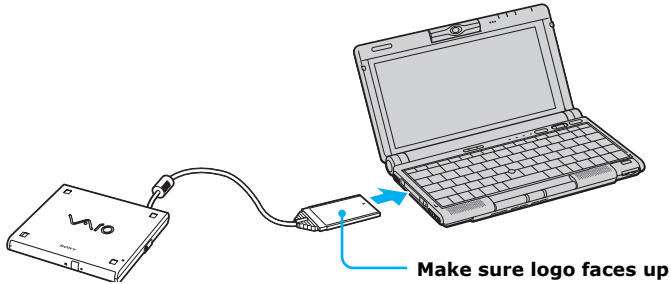

 A protective cover is attached to the lens of the optical drive at the factory. Before using the optical drive, remove the protective cover.

To insert a disc

- 1 Press the Eject button. The disc tray slides out.

Optical Drive

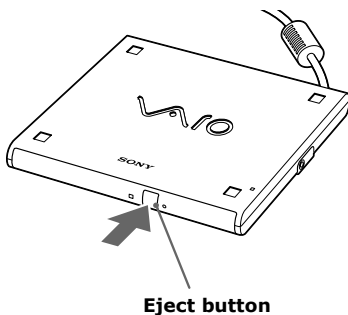

- 2 Place the disc in the tray with the label side facing up.

- 3 Push the disc onto the hub until the disc clicks into place.

Inserting Disc

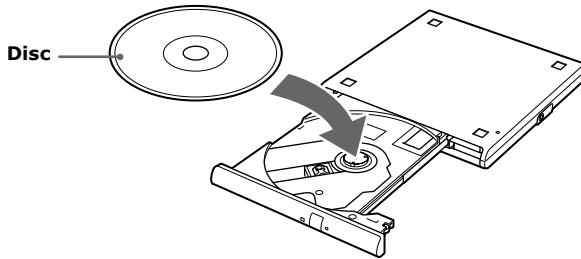

- 4 Close the tray by pushing it in gently. The Busy indicator on the drive flashes while your computer is reading data from the disc.

Flashing Busy Indicator

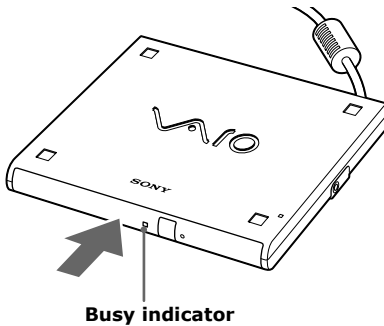

To remove the drive

Remove the PC Card from the computer. See “To remove the floppy disk drive when the computer is on” for more information.

Notes on CD and DVD discs

Handling CD or DVD discs

- ❑ Do not touch the surface of the disc.
- ❑ Do not drop or bend the disc.
- ❑ Avoid using adhesive labels to identify your discs. Adhesive labels may come off while the disc is in use in your optical drive, and may cause damage to the unit.

Cleaning CD or DVD discs

- ❑ Fingerprints and dust on the surface of a disc may cause data reading errors. Proper care of the disc is essential to maintain its reliability. Do not use solvents such as benzine, thinner, commercially available cleaners or anti-static spray, as they may cause damage to the disc.
- ❑ For normal cleaning, hold the disc by its edge and use a soft cloth to wipe the surface from the center out.
- ❑ If the disc is badly soiled, moisten a soft cloth with water, wring it out well, and use it to wipe the surface of the disc from the center out. Wipe off any remaining moisture with a dry soft cloth.

Connecting an i.LINK Optical Disc Drive

You can use an optional i.LINK®* optical disc drive (PCGA-CRWD1) with your computer. This Sony VAIO® computer is preinstalled with software that enables you to create CDs and play DVD movies. The i.LINK optical disc drive draws power from the computer through the power cable that is integrated with the VAIO computer Peripheral Cable. This peripheral cable connects to both the i.LINK port and peripheral cable DC Out jack on the left side of the computer.†

To connect an i.LINK optical disc drive

Use a VAIO® Computer Peripheral Cable (supplied with the optional PCGA-CRWD1) to connect the optical disc drive to the computer.

 Before connecting or disconnecting this drive, close any active applications to help prevent data loss.

- 1 Turn on power to the computer. Insert the L-shaped plug of the VAIO® Computer Peripheral Cable into the matching jack on the rear of the i.LINK

* i.LINK is a trademark of Sony used only to designate that a product contains an IEEE1394 connection. The i.LINK connection may vary, depending on the software applications, operating system and compatible i.LINK devices. All products with an i.LINK connection may not communicate with each other. Refer to the documentation that came with your compatible i.LINK device for information on operating conditions and proper connection. Before connecting compatible i.LINK PC peripherals to your system, such as a CD-RW or hard disk drive, confirm their operating system compatibility and required operating conditions.

† If you connect and use an optional drive when your computer is running on battery power, the battery life will be reduced.

Change text in this variable definition to document title.

drive. Secure the plug by turning the screw on the cable connector clockwise.

Connecting i.LINK optical disc drive

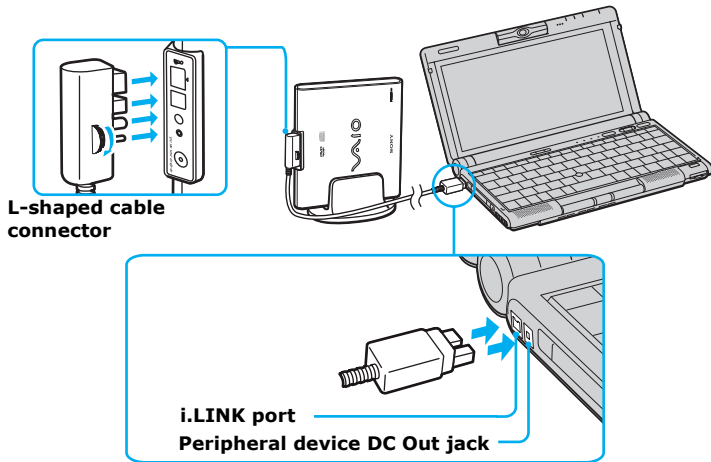

- 2 Insert the straight-shaped, two-prong plug of the VAIO® computer peripheral cable into both the computer's i.LINK port and peripheral device DC Out jack.
- 3 The i.LINK drive's power indicator lights up, and the computer will automatically detect and identify the connected drive.
- 4 Click Start on the Windows® taskbar, and select My Computer to verify that an icon for the i.LINK optical disc drive has been added in the window.

 PCGA-CRWD1 is compatible only with certain Sony VAIO® PCG series computers preinstalled with Microsoft® Windows® XP Home Edition or Professional.

Notes on using i.LINK optical disc drives

- ❑ You can use the supplied Application Recovery, Driver Recovery, and System Recovery CDs with an i.LINK optical disc drive. See “Application, Driver, and System Recovery CDs” for more information.
- ❑ Do not use an optional i.LINK optical disc drive and an optional optical disc drive with PC Card at the same time. Connecting both drives may cause a system malfunction.

Change text in this variable definition to document title.

Connecting a USB Mouse

You can connect an optional USB mouse, such as the Sony PCGA-UMS1 series, to your computer.

To connect a USB mouse

Plug the mouse cable into the USB port. PCGA-UMS1 series drivers have already been installed.

Connecting a USB Mouse

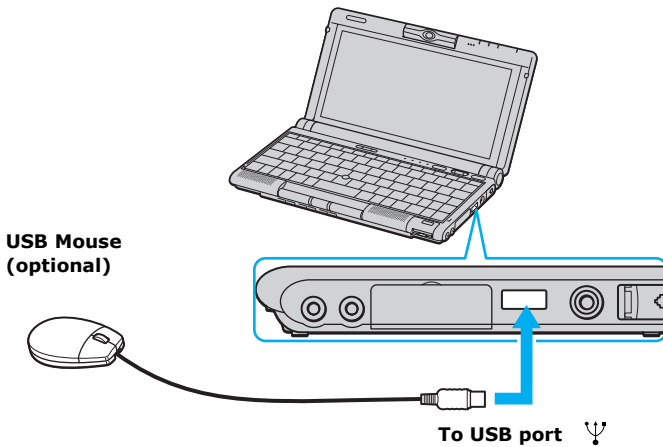

 A serial mouse or PS/2® mouse is not compatible with the VAIO® C1 PictureBook® computer.

See the manual supplied with your mouse for more information on its installation and use.

Connecting VAIO Computers

Connecting with i.LINK

You can use an optional i.LINK®* cable to connect your VAIO® computer to another VAIO computer that has the preinstalled Microsoft® Windows® operating system or the Sony Smart Connect software preinstalled. You may use an i.LINK cable (not supplied) to connect the two systems and then use one computer to edit, copy, or delete files on the other computer. You can also print from a printer that is attached to either computer.

Connecting with an i.LINK cable

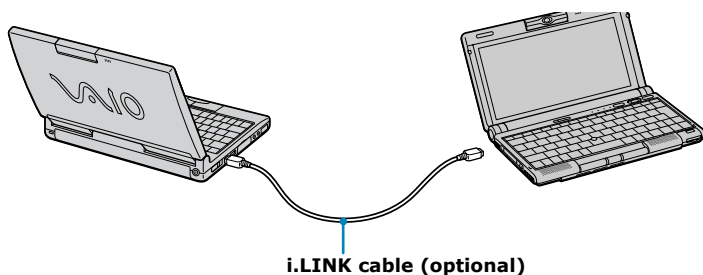

 When you connect two VAIO computers, you must assign each computer a unique name. The computers can be identified by this unique name when the two computers are networked together.

To connect VAIO computers that do not have the latest Windows® operating system, Smart Connect software may be necessary. Consult the Sony Computing Support Web site for support options (<http://www.sony.com/pcsupport>).

* i.LINK is a trademark of Sony used only to designate that a product contains an IEEE1394 connection. The i.LINK connection may vary, depending on the software applications, operating system and compatible i.LINK devices. All products with an i.LINK connection may not communicate with each other. Refer to the documentation that came with your compatible i.LINK device for information on operating conditions and proper connection. Before connecting compatible i.LINK PC peripherals to your system, such as a CD-RW or hard disk drive, confirm their operating system compatibility and required operating conditions.

Connecting an i.LINK Device

Your VAIO® computer includes an i.LINK®* S400 (IEEE1394) port, which you can use to connect a compatible i.LINK device, such as an i.LINK enabled digital video camera recorder. See the manual supplied with your digital video camera recorder for more information on its installation and use.

 You can purchase compatible i.LINK cables from your local retailer, through the Sony VAIO® Direct Web site (<http://vaio.sonymstyle.com>), or by calling 1-888-315-7669 (toll free).

* i.LINK is a trademark of Sony used only to designate that a product contains an IEEE1394 connection. The i.LINK connection may vary, depending on the software applications, operating system and compatible i.LINK devices. All products with an i.LINK connection may not communicate with each other. Refer to the documentation that came with your compatible i.LINK device for information on operating conditions and proper connection. Before connecting compatible i.LINK PC peripherals to your system, such as a CD-RW or hard disk drive, confirm their operating system compatibility and required operating conditions.

To connect a digital camcorder

- ❑ Plug one end of an i.LINK® cable into the **i** S400 port on the left side of the computer and the other end into the DV In/Out port on the digital camcorder.

Connecting a Digital Camcorder

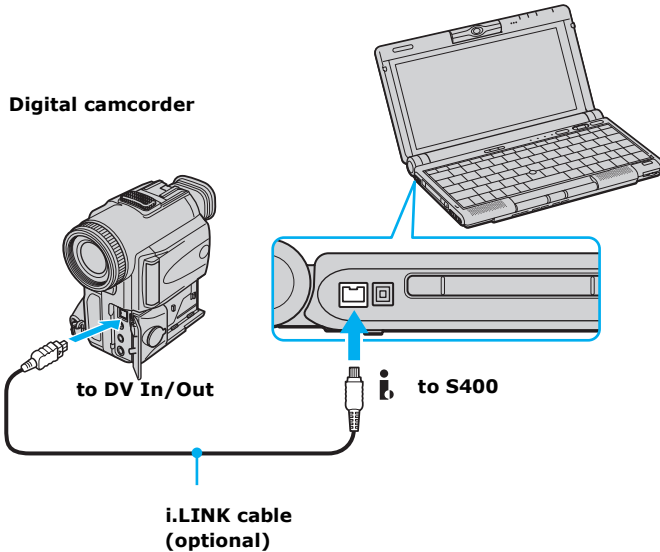

Notes on connecting an i.LINK device

- ❑ A connection to a Sony digital camcorder is pictured above; your digital camcorder may need to be connected differently.
- ❑ See the manual supplied with your digital camcorder for more information on its installation and use.
- ❑ Only Sony digital video camera ports labeled “DV In/Out” or “i.LINK” are compatible i.LINK devices.
- ❑ Do not connect more than one digital video camera at a time. The software supplied with your computer will not recognize multiple cameras.

- ❑ The i.LINK port does not supply power to external devices. If the external device requires power from the i.LINK port, you cannot use the device with the computer.
- ❑ The C1 PictureBook® computer supports transfer rates up to 400 Mbps; however, the actual transfer rate is limited to the maximum transfer rate supported by the external device. If multiple devices are connected, the transfer rate will be the lowest maximum transfer rate for the connected devices.
- ❑ The i.LINK® features available may vary depending on the software applications you use. See the documentation supplied with your software for more information.
- ❑ The i.LINK cables compatible with your VAIO® computer include cables with the following part numbers: VMC-IL4415 (a 1.5-meter cable with a 4-pin connector at each end), VMC-IL4615 (a 1.5 meter-cable with a 4-pin connector at one end and a 6-pin connector at the other), and VMC-IL4435A (a 3.5-meter cable with a 4-pin connector at each end). You can purchase these cables from your local retailer, through the Sony VAIO® Direct Web site (<http://www.sonydirect.com>), or by calling 1-888-315-7669 (toll free).

Connecting an External Display

You can connect an external display to your VAIO® C1 PictureBook Computer. For example, you can use the computer with any of the following:

- Computer display or monitor (See “To connect a computer display” for more information)
- Projector (See “To connect a projector” for more information)
- TV (See “To connect a TV” for more information)

To connect a computer display

- 1 First make sure the port replicator is connected to the computer.
- 2 Connect the computer display's display adapter to the supplied port replicator's Monitor port.

Connecting a Display

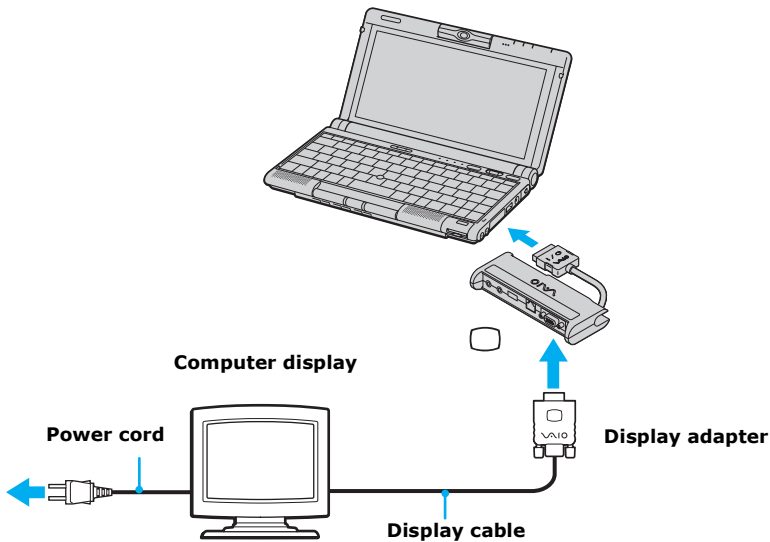

 See the manual supplied with your computer display for more information on its installation and use.

To connect a projector

You can use a projector as an external display, such as the Sony LCD Projector.

You can connect a projector using the supplied Display adapter.

- 1 First make sure the port replicator is connected to the computer.
- 2 Plug one end of the RGB signal cable (not supplied) into the port replicator's Monitor port, and the other end into the projector's corresponding port.

- 3 Plug the audio cable into the Headphone  jack.

Connecting a Projector

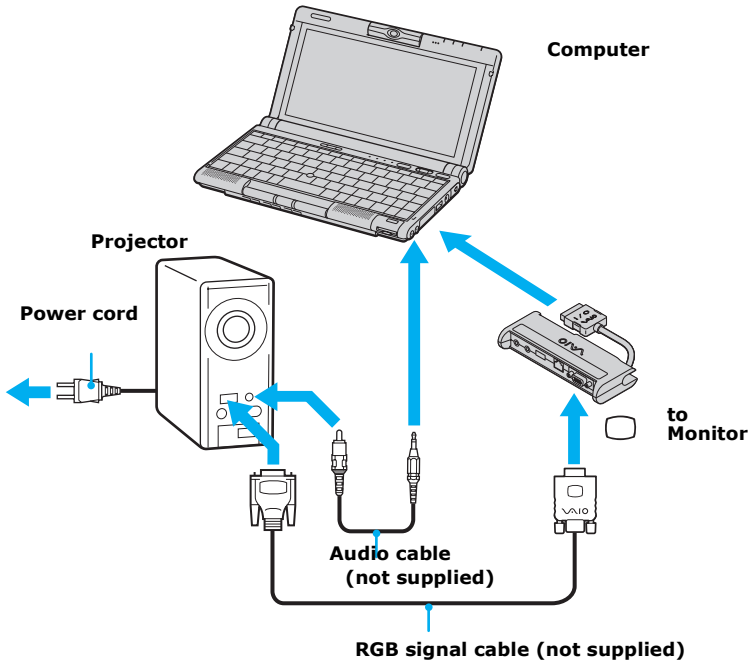

 See the manual supplied with your projector for more information on its installation and use.

You may not be able to display the computer's LCD and the external display together, depending on the specific computer display or projector used.

Connect the AC adapter after you finish connecting all other peripheral devices. Turn on all the peripheral devices before you turn on the computer.

To connect a TV

Use the supplied AV cable to connect your TV monitor to your computer.

Change text in this variable definition to document title.

- 1 First make sure the port replicator is connected to the computer.
- 2 Plug the supplied AV cable into the port replicator's AV/TV Out jack.
- 3 Plug the other ends of the AV cable into the TV, as shown below.

Connecting a TV

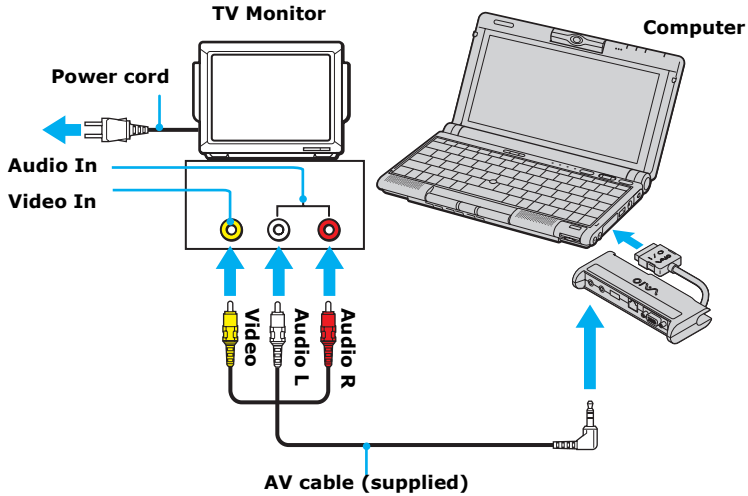

 See "Selecting the Display Mode" for more information.

Connecting a USB Printer

You can connect a Windows® compatible USB printer to your computer to print documents.

 To use a printer, first install the driver software supplied with your printer.

To connect a printer

Plug the optional USB printer cable into the USB port on your computer and the USB port on your printer. You can also connect the USB printer cable into the USB port on the supplied port replicator.

Connecting a Printer

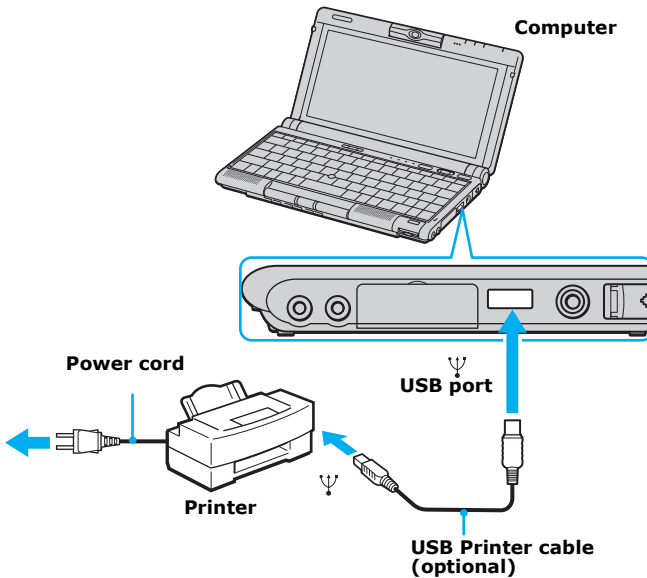

 See the manual supplied with your printer for more information on its installation and use.

Change text in this variable definition to document title.

Connecting an External Microphone

You can enhance the quality of sound input by using an external microphone.

 Make sure your microphone is designed for computer use.

To connect an external microphone

Use the  symbol to locate the Microphone jack. Plug the microphone cable into this jack.

Connecting a Microphone

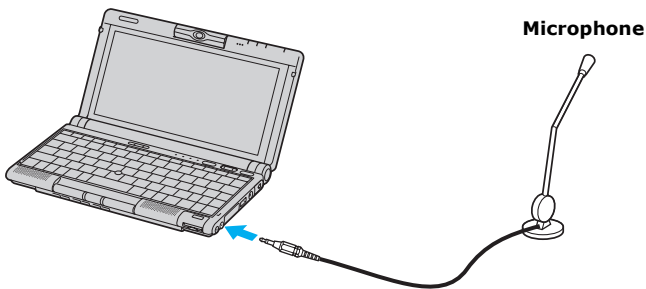

 See the manual supplied with your microphone for more information on its installation and use.

To record from a microphone or audio equipment

You can record messages, memos, or other recordings in analog by connecting a microphone or other audio equipment to the Microphone jack of your computer and then switching the jack functionality. The Microphone jack is for MIC IN (monaural).

To switch the microphone jack functionality

To switch the Microphone jack functionality for use with a microphone or an audio device:

- 1 Double-click  on the task tray located in the lower right corner of the Desktop window. The Volume Control window appears.
- 2 From the Options menu, click Properties. The Properties window appears.
- 3 In the Adjust Volume panel, select Recording, and then click OK. The Recording Control window appears.
- 4 Select either Microphone or Line.

 When you are recording using a microphone, select Microphone. If you are recording using other audio equipment, select Line.

To adjust sound volume in the Recording Control window

When Microphone or Line are not displayed in the Recording Control window, do the following:

- 1 Select Options and click Properties.
- 2 Click the item you want to display in Control.
- 3 Click OK.

 You can only adjust the recording volume in the Recording Control window in step 3. If you adjust the volume in step 1, the adjustment is only effective for playing sound. It does not adjust the volume for recording sound.

To increase the sound of the microphone

- 1 Double-click  on the task tray located in the lower right corner of the Desktop window. If Microphone is not displayed, from the Options menu click Properties, select Microphone from the Control panel, and then click OK.
- 2 From the Microphone panel, click Advanced. The Advanced Controls for Microphones dialog box displays.
- 3 Click Mic 20dB in Other Controls, and then click Close.

To adjust sound device volume

You can adjust the sound device volume for playing or recording.

Change text in this variable definition to document title.

To adjust the volume when playing, double-click  in the task tray located in the bottom right corner of the Desktop window. The Volume Control window is displayed.

To adjust the sound of other devices, do the following:

- 1 Select Options and click Properties.
- 2 In the Volume Adjust window, select Playback.
- 3 Click the check box of the item you want to display in Control.
- 4 Click OK.

<i>Sound device</i>	<i>Function</i>
Volume Control	Adjust the sound level from the speakers or headphones.
WAVE	Adjust the wavfile sound or the system sound of Windows.
PC Beep	Adjust the beep sound when inserting or removing the PC Card and other devices.
Telephone	Adjust the modem or telephone line volume.
Microphone	Adjust the internal or external microphone volume.
Line	Adjust the audio equipment volume.
CD Audio	Adjust the volume of the CD in the optional optical drive.
MIDI Out	Adjust the MIDI sound.
3D Wide	Widen the sound effect. (This is effective for games and similar applications.)

To set the microphone to echo

- 1 From the Start menu, select Control Panel.
- 2 Double-click YAMAHA DS-XG.
- 3 Select the Echo tab.
- 4 You can also customize the setting by choosing options such as Delay Time and Feedback.
- 5 Click OK.

 When recording or using microphone echo, some software options may not be available.

To modify the MIDI sound

- 1 From the Start menu, select Control Panel.
- 2 Click the YAMAHA DS-XG Audio Config icon. (If you do not see the icon that you are looking for, click “Display all the options of the Control Panel.”)
- 3 Select the Synthesizer tab.
- 4 Select the desired effect, and then click OK.

To adjust the sound volume when recording, double-click  in the task tray located in the lower right corner of the Desktop window.

- 1 From the Options menu, select Properties.
- 2 In the Volume Adjust window, select Recording, and then click OK. The Recording Control window appears.

Change text in this variable definition to document title.

You can adjust the sound using the Smart Label software (included) or the sound recorder.

<i>Sound device</i>	<i>Function</i>
Telephony	Adjust the modem or telephone line sound.
Microphone	Adjust the internal or external microphone sound.
Line	Adjust the audio equipment sound volume.
CD Audio	Adjust the digital sound volume of CD of the optional optical disc drive.
Stereo Out	Adjust the sound from Volume Control. The bass boost function is not enabled.

Connecting External Speakers

You can enhance the sound quality of your computer by connecting external speakers.

To connect external speakers

- ❑ Use the  symbol to locate the Headphone jack. Plug the speaker cable into this jack.

Connecting external speakers

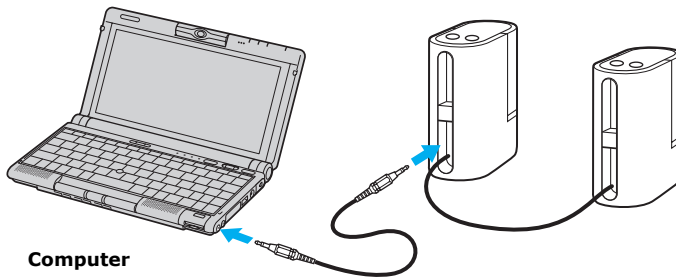

Notes on using external speakers

- ❑ Make sure that the speakers you purchased are designed for computer use.
- ❑ Before you turn on the speakers, turn down the volume.
- ❑ Do not place floppy disks or other data disks on or near the speakers; the speakers' magnetic field may damage the data on the disks.

See the manual supplied with your speakers for more information on their installation and use.

Expanding Your Computer's Capabilities

The following peripheral devices can be connected to your computer, to expand the capabilities of your computer and enhance its versatility to meet your various business or personal needs:

- A Personal Digital Assistant (PDA)
- The Wireless LAN Access Point
- The Wireless LAN PC Card

 For information on available Sony products, go to: <http://www.sonymstyle.com/vaio>.

Personal Digital Assistant

A handheld PDA is the quintessential personal planner and entertainment center that fits in your pocket. With a PDA, you can easily perform the following functions:

- Enter your schedule details in the calendar and view them by the day, week, or month, and even set an alarm to remind you of important events.
- Keep your contact names, addresses, phone numbers, and other details in the address book, and find them when you need them.
- Add tasks to the To Do List, prioritize them, and assign them due dates.
- Synchronize your data with the software on your computer, to back up your data.
- Track expenses when you are out of the office, then transfer the data to your computer.
- Exchange data with your computer.

The Wireless LAN Access Point

The Wireless LAN Access Point, which is also called the Access Point, is designed for building a wireless LAN (Local Area Network) environment. The Access Point comes with the Wireless LAN PC Card and required software. You can easily build a wireless LAN environment by plugging the Access Point into an AC power outlet, installing the Wireless LAN PC Card in your computer, and using the provided software. Because a wireless LAN configuration requires no wiring, you can operate multiple computers more freely than ever before.

You can also connect your Access Point to a telephone line, Integrated Services Digital Network (ISDN) router, cable modem, or Digital Subscriber Line (xDSL) modem to share access to the Internet among multiple computers.

The Wireless LAN PC Card

The Wireless LAN PC Card, which comes with the Wireless LAN Access Point, can be purchased separately and is designed for building a wireless LAN environment. The Wireless LAN PC Card can be used with or without the Access Point. With the Access Point, you can build a wireless LAN between computers that are equipped with the Wireless LAN PC Card and gain access to the Internet. Without the Access Point, you can achieve direct communication (Peer to Peer mode) between computers.

 For information on available Sony products, go to:
<http://www.sonymstyle.com/wirelesslan>.

Change text in this variable definition to document title.

Customizing Your VAIO Computer

You can customize the settings of your computer. The following sections briefly describe how to change your computer's default settings. You can also refer to Sony Notebook Setup Help for more detailed information.

- ❑ Displaying the Sony Notebook Setup Screen
- ❑ Controlling Power Management
- ❑ Displaying Battery Information
- ❑ Changing the Window Design of Sony Software
- ❑ Selecting the Display Mode

Change text in this variable definition to document title.

Displaying the Sony Notebook Setup Screen

 See the manual supplied with your computer display for more information on its installation and use.

To display the Sony Notebook Setup screen:

- 1 Click Start on the Windows® taskbar.
- 2 Point to All Programs and click Sony Notebook Setup.

Sony Notebook Setup Screen



- 3 Select the tab for the item you want to change. See “Sony Notebook Setup tabs” for more information.
- 4 After you finish making your changes, click OK.

Sony Notebook Setup tabs

<i>Tab</i>	<i>Description</i>
About This Computer	Display system information, including memory capacity, serial number, and BIOS version.
Initial Setting	Change the volume of the sounds that play while the operating system is loading. Select the order of drives and devices from which you want to load the operating system. You can specify the hard drive as well as other drives inserted into your computer.
Power On Password	Set the password to secure your computer.
Bass Boost	Set the Bass Boost option.

 For more information about each option, click Help on the Sony Notebook Setup screen to display the Help file.

Controlling Power Management

The PowerPanel™ utility allows you to control the power management of your computer and provides key information about system activity and battery life. The following sections briefly describe how to conserve your computer's battery power. You can also refer to PowerPanel Help for more detailed information. To activate a profile or command, see “Displaying Battery Information” for details.

To view the Power Management status icons

The Power Management status icons are displayed in the task tray at the lower right side of your screen. Move the pointer over the icons to see the tool tip that displays information about the active profile. The Battery status icon indicates battery power level and the CPU status icon indicates the performance level of the CPU.

To activate the Power Management toolbar

- 1 Right-click the taskbar at the bottom of the screen.
- 2 Select Toolbars from the pop-up menu, and then click Power Management. The Power Management toolbar appears on the taskbar.

The current profile icon is highlighted on the Power Management toolbar. It is the first icon farthest to the left, and its appearance changes depending on which power management profile is currently selected. To change the power management profile, click the current profile icon, and then select a profile from the pop-up list. See “Power Management profiles” for a description of available options. To select another power management command, click that icon in the Power Management toolbar.

 When you use the battery pack to power your computer, your system selects the Maximum Battery Life power management profile by default. If you select a different power management profile while using battery power, that profile is selected automatically the next time you use the battery pack to power your computer.

Refer to the PowerPanel Help for information on customizing the Power Management toolbars.

You can change the power management settings, such as the system timer and the brightness of the screen.

To customize Power Management settings







- 1 Click the Current Profile icon on the Power Management toolbar.
- 2 Select Edit/Create Profiles from the menu.
- 3 Click a profile whose setting you want to change from the list in the left field.
- 4 Double-click an item whose setting you want to change from the list in the right field.
- 5 Click the desired setting.
- 6 Click the File menu, and then click Save.
- 7 Click the File menu, and then click Exit.

Power Management profiles

The PowerPanel™ utility provides several predefined power management profiles. Each profile consists of a group of power management settings that are designed to meet specific power management goals — ranging from maximum power management to no power management. You can change the settings for

Change text in this variable definition to document title.

any of the predefined profiles (except for the Disable Power Management profile), or you can create your own profile to suit your portable computing needs. The predefined profiles are:

Icon	Description
	Maximum Performance Provides the best system performance while still conserving power.
	Maximum Battery Life Provides power saving features to give you maximum battery life and good performance. It slows the computer and puts it into Standby mode after a specified time period.
	Ultimate Battery Life Extends the Maximum Battery Life by disabling ports such as the i.LINK port. This profile disables many applications such as Memory Stick, DVgate, and Smart Capture.
	Disable Power Management Turns off all power management features such as Standby and Hibernate modes. You can not change the settings of this profile.
	AC Power The power management state when AC power is in use. Similar to the Power Management Off setting. Power Management automatically loads the AC profile unless you disable this feature.
	Games Disables the display and the Hard Disk Standby timer.
	Presentation Keeps the display on at all times while it conserves power. This option is ideal for slide show presentations. You can establish settings for LCD (Video) Standby, Hard Disk Standby, and Standby to optimize power management for your system.

Icon

Description



Camera

Optimizes performance and power requirements for camera usage.



Word Processing

Optimizes power management with longer timeouts on the hard disk and display screen. You can also establish settings for LCD (Video) Standby, Hard Disk Standby, and Standby to optimize power management for your system.



Spreadsheet

Optimizes performance and power requirements for spreadsheet applications.



Communications

Extends battery life by initiating a quick display timeout. The Internal modem remains powered. You can also establish settings for LCD (Video) Standby, Hard Disk Standby, and Standby to optimize power management for your system.



Automatic Profile Selection



Automatically switches to a profile suitable for active applications.



Do not choose the Automatic Profile Selection when connected to AC power.

Power Management commands

PowerPanel™ also provides power management commands that you can use to activate specific power management functions and to control power for a specific device. You can use these commands to override a profile setting or initiate an immediate action.

Icon	Description
	Standby Puts the system into Standby mode, a power management state that saves the state of the system and peripheral devices in memory (RAM). Power consumption reduces to a minimum, and the system remains on. To return the system to the active state, press any key or the power button on your computer.
	Hibernate Provides for the lowest level of power consumption. The system writes the state of the system and peripheral devices to the hard disk drive and turns off the system power. To return the system to the original state, use the power button to turn on power. The system saves the data in the Save to Disk Partition on the hard disk drive.
	LCD (Video) Standby Turns off the video display to save power. If you turn off the Video Standby timer, the display remains active except when the system enters Standby mode. The video display system is one of the largest consumers of power in the system.

Conserving battery power

When using the computer with a battery, the LCD display and the hard disk drive can be set to switch off automatically to conserve battery power.

See “Power Management profiles” for more information.

Displaying Battery Information

You can display information for the battery on your computer. The following sections briefly describe how to display your computer's general battery information. You can also refer to PowerPanel Help for more detailed information.

To activate the Battery Information toolbar

- 1 Right-click the taskbar at the bottom of the screen.
- 2 Select Toolbars from the pop-up menu, and then click Battery Information. The Battery Information toolbar appears on the taskbar.

You can also view the total capacity remaining in the battery by placing the pointer over the battery status icon in the task tray on the lower right side of the screen.

Battery Information Toolbar



- Percentage indicator** — Displays the percentage of the remaining capacity.
- Time indicator** — Displays estimated time (hours:minutes) remaining before the battery fully drains, also referred to as the time-to-empty.

Battery icon descriptions

Battery icon	Battery status
	Charging



Change text in this variable definition to document title.

Battery icon **Battery status**



Fully charged



Discharging



No battery

Displaying detailed battery information

Double-click the battery icon on the task tray to display the Battery Information window. The screen appears displaying the Battery tab, which contains information such as the estimated time-to-empty and charging time.

Battery Information Window

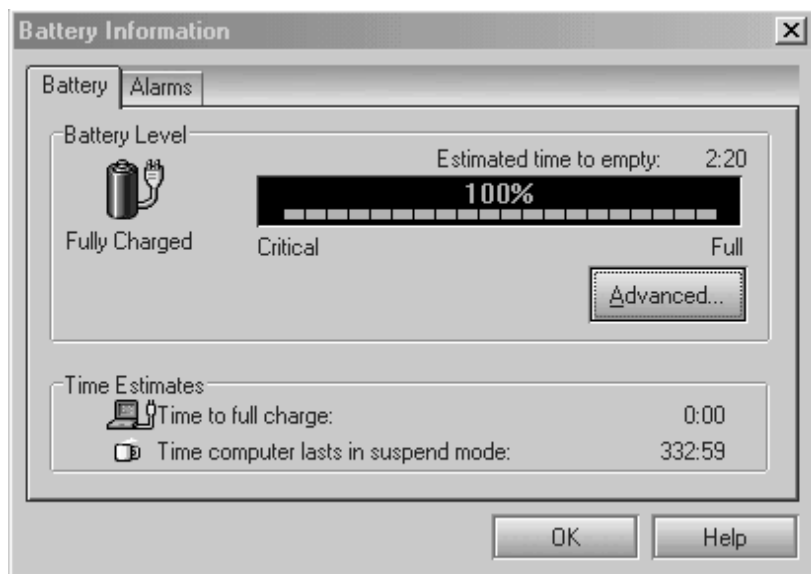

Customizing the Battery Information toolbar and alarm system

You can customize the Battery Information toolbar to suit your portable computing needs, including modifications to the alarm settings. Refer to PowerPanel Help for more information.

Changing the Window Design of Sony Software

To change the window design

- 1** Click the Start button, then select Control Panel.
- 2** In the left window pane of Control Panel, click “Switch to Classic View.”
- 3** Double-click UI Design Selector.
- 4** Click << or >> and select the desired design.
- 5** Click Apply. The “UI Design Selector” window design changes. The window design for your Sony software will match the "UI Design Selector" window.
- 6** To try another selection, click << or >> and then click OK to close the UI Design Selector.

 This feature is available with UI Design Selector-compatible software only.



Selecting the Display Mode

This computer uses the ATI video controller. You can select which display is used when the computer is connected to an external monitor. When you connect an external display, you can switch the display mode between your computer's LCD display and the external monitor.

- 1** Click the Start button, point to Control Panel, and click Appearance and Themes. The Appearance and Themes window appears.
- 2** Click the Display icon. The Display Properties window appears.
- 3** Click the Settings tab, and then click the Advanced button. The ATI Mobility Radeon™-M Properties dialog box appears.

Change text in this variable definition to document title.

- 4 Click the Displays tab and select the display settings by clicking the  icon on the panel of your display choice. For more information, click the Help button.

 If you cannot see your movie or DVD on the external display, change the monitor or TV setting by clicking on the Secondary  icon and changing it to Primary .

You may not be able to display the computer LCD screen and an external display or projector at the same time, depending on the types of computer displays and projectors you are using.

Turn on the computer after you turn on the peripheral devices.

ATI Mobility Radeon Properties Screen

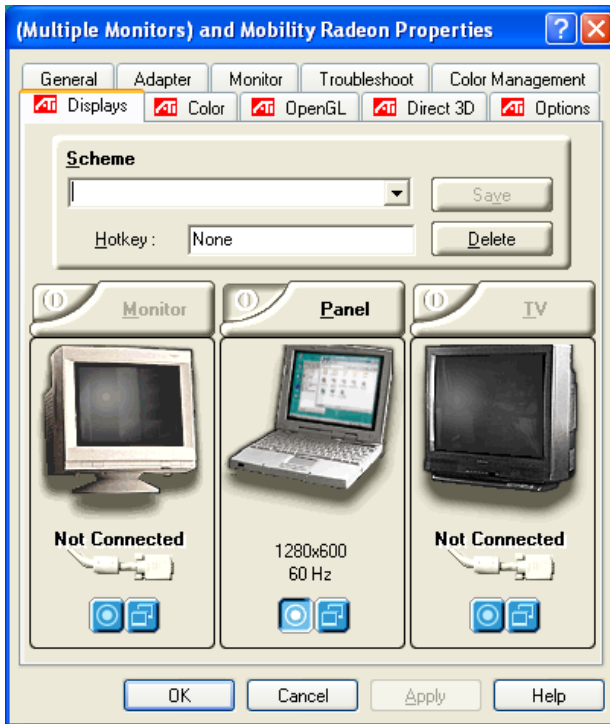

Adding Memory

In the future you may want to install memory modules to expand the functionality of your computer. See the Specifications flyer supplied with your computer for the amount of memory preinstalled on your computer. Expansion memory modules are available as options. For memory upgrades, use only PCGA-MM128T modules. This section provides you with information on removing and replacing a memory module:

- ❑ Precautions and Procedures
- ❑ Removing a Memory Module
- ❑ Installing a Memory Module
- ❑ Confirming Added Memory Capacity

Precautions and Procedures

The procedures described below assume familiarity with the general terminology associated with personal computers and with the safety practices and regulatory compliance required for using and modifying electronic equipment.



**Sony recommends that memory upgrades be performed by an authorized Sony Service Center. To find the nearest center or agent, go to:
<http://www.sony.com/pcsupport>.**

Be careful when installing a memory module in your computer, and be sure to observe the proper safety precautions listed below. Mistakes that occur when installing or removing a memory module may cause a malfunction.

- ❑ Disconnect the system from its power source and from any telecommunications links, networks, or modems before you open the system or follow any of the procedures described below. Failure to do so may result in personal injury or equipment damage.
- ❑ Electrostatic discharge (ESD) can damage disk drives and other components. Perform the procedures described below only at an ESD workstation. If such a station is not available, do not work in a carpeted area, and do not handle materials that produce or hold static electricity (cellophane wrappers, for example). Ground yourself by maintaining contact with an unpainted metal portion of the chassis while performing the procedure.
- ❑ Do not open the memory module package until you are ready to install the module. The package protects the module from ESD.
- ❑ Use the special protective package to store a memory module and prevent ESD, or wrap the memory module in aluminum foil.

Typical expansion memory configuration

Total System Memory (MB)	On board (MB)	Slot (MB)
128	128	0
256	128	128

Removing a Memory Module

- 1 Turn off the computer and all peripheral devices.
- 2 Disconnect the power cord and all cables from the computer, and remove the battery.

 The interior of the computer becomes extremely hot during operation. Wait at least one hour for the computer to cool down before you remove the screws.

- 3 Use an appropriate screwdriver to loosen and remove the screw that fastens the memory module cover plate on the bottom of the computer.



To avoid damaging the computer, do not remove or loosen any other screws.

Removing Cover Plate

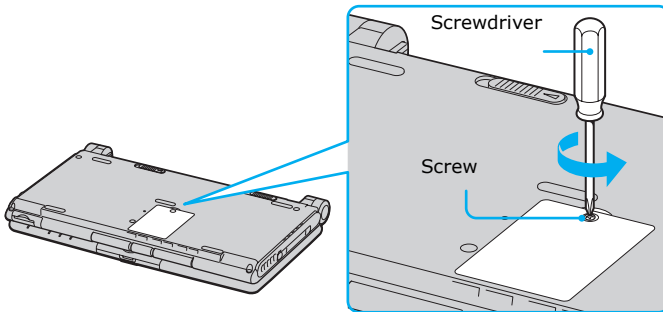

- 4 Remove the memory module cover plate.
- 5 Touch a metal object (such as the connector panel on the back of your computer) to discharge static electricity, then remove the memory module, pulling it out in the direction of the arrows.

Removing a Memory Module

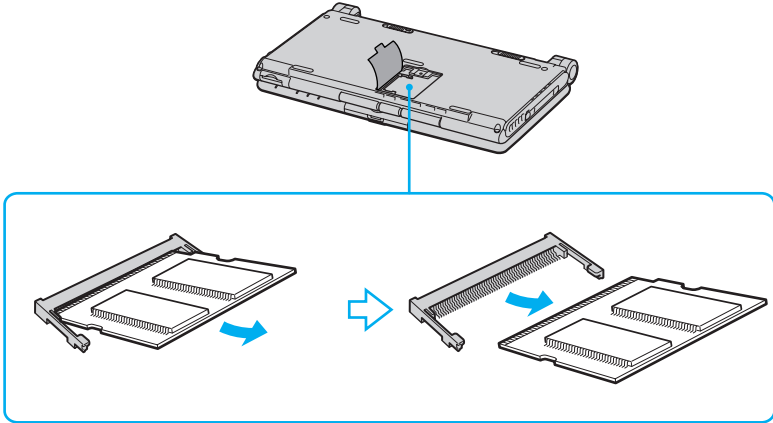

- 6 Close the cover panel and replace the fastening screw.

Installing a Memory Module

- 1 Perform steps 1 through 4 as described in the “Removing a Memory Module” section.



To avoid damaging the computer, do not remove or loosen any other screws.

- 2 Touch a metal part of the computer (such as the connector panel on the back of your computer) to discharge any static electricity accumulated on your body, then remove the module from its protective package.
- 3 Install the memory module by holding the module edge connector pointing down with the notch on the right, and then insert it diagonally into the empty slot.

A Memory Module

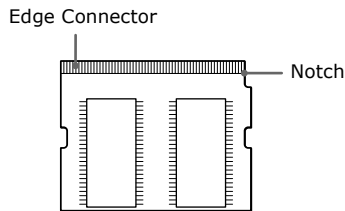

- 4 Lower the memory module until it clicks into place on both ends.

Installing a Memory Module

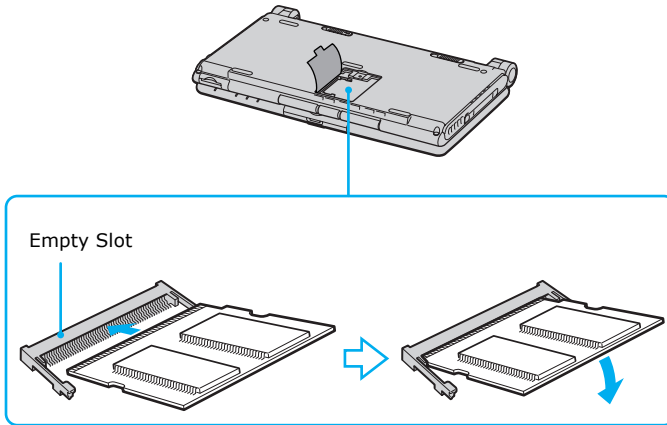

Do not touch any part of the motherboard or the other components inside the computer.

- 5 Close the cover panel and replace the fastening screw.

Confirming Added Memory Capacity

- 1 Turn on the computer.
- 2 Click Start on the Windows® taskbar, point to All Programs, and then click Sony Notebook Setup.
- 3 Click the About This Notebook tab. Verify that the System Memory displayed in the left panel matches the amount of memory installed.

 If the amount of memory is not correct, shut down the computer, and reinstall the memory module. See “Removing a Memory Module” and “Installing a Memory Module” for instructions.

Sony Notebook Setup Dialog Box



Change text in this variable definition to document title.

About the Software on Your Computer

Your VAIO® computer is ready to help you work, play, learn, and communicate as soon as you turn it on. This section gives you the following:

- ❑ An overview of the various software that come with your computer and the activities you can perform with your software
- ❑ Details on your Sony application, driver, and system recovery CDs

Overview

Your computer may not be supplied with all of the software listed below, depending on the configuration you purchased.

Adobe® Acrobat Reader™

Adobe Systems Inc.

Acrobat Reader software enables you to view, navigate, and print electronic documents in Adobe Portable Document Format (PDF), an open file format that is intended to preserve the fidelity of documents created on all major computer platforms.

Adobe Photoshop® Elements

Adobe Systems Inc.

Using state-of-the-art image editing tools, you can unleash your artistic ability and create digital images for print, e-mail and posting to the Web. The versatile image capturing options allow you to start working with digital and traditional photos immediately. Explore endless creative possibilities for your personal images with Adobe Photoshop Elements.

America Online®

America Online, Inc.

America Online is a popular Internet online service. Stay in touch with family and friends with easy-to-use e-mail. Manage your personal finances, get the latest news and sports scores, and chat with thousands of others who share your interests.

Apple QuickTime™

Apple Computer Inc.

QuickTime is the Apple technology that makes video, sound, music, 3D, and virtual reality come alive for our Internet browser and Windows.

ArcSoft PhotoPrinter® 2000 Pro

ArcSoft, Inc.

ArcSoft PhotoPrinter 2000 is an easy-to-use, advanced printing program that lets you quickly lay out multiple images in multiple sizes on a single sheet of paper. PhotoPrinter Pro offers a wide selection of templates including landscape, portrait, free style, mixed sizes, custom templates and more. The application includes enhancement tools and special effects for improving photos while giving you the ability to add text to any image.

DigitalPrint

Sony Electronics Inc.

This image management software makes it fun and easy to edit, import, and organize your digital pictures in a photo album for rich digital printing to any standard color laser or inkjet printer. DigitalPrint can also be used to make custom CD labels for your audio CDs.

DVgate™

Sony Electronics Inc.

Connect a digital video camera recorder to the i.LINK® connector and capture your own video clips and still images. You can edit the clips from your video, add others, and combine clips into new movie segments. You can also save your images in a variety of popular file formats.

EarthLink™ Network Total Access

EarthLink Network Inc.

An Internet Service Provider that supplies access, information, and assistance to its customers, introducing them to the Internet. Member benefits include e-mail, newsgroups, a Personal Start Page, a free 6 MB Web site, a member magazine, and 24-hour technical support.

Microsoft® Internet Explorer

Microsoft Corp.

Internet Explorer delivers the Web the way you want it. It is safe, easy to use, and you can personalize how you access the Web. Outlook Express and other tools in Internet Explorer also help you have a great experience when you are on the Web.

Microsoft® Word

Microsoft Corp.

Microsoft Word makes it easy to create shared Web, e-mail, and print documents for use around the world. It embraces HTML as a first-class file format and extends Word's ease-of-use to the Web and e-mail. Word also extends that ease-of-use to international users, making it simple to create multilingual documents.

MovieShaker™

Sony Electronics Inc.

Sony's original MovieShaker software creates personal movies that have transitions, background music and text. Just import your video clips and "shake" with a click of the mouse. Your personal movies are easy to create and fun to share with family and friends.

PC-Cillin® 2000

Trend Micro, Inc.

PC-Cillin provides portable, easy-to-use, real-time antivirus security at your computer's entry point (beaming, synchronization, Internet access) to defend against potential threats hidden inside files, e-mail, or on the Web.

PictureGear™

Sony Electronics Inc.

This image management software displays images from your hard drive, a Sony digital still camera, or a Sony Mavica® camera. The images appear in a convenient light-table format, so that you can easily view the contents of an entire folder.

Quicken®

Intuit, Inc.

Quicken is a fast, easy way to organize your finances. Quicken works just like your checkbook, so it is easy to learn and use. Quicken manages all your finances, bank accounts, credit cards, investments, and loans. You can even pay your bills online.

RealJukebox®

RealNetworks Inc.

RealJukebox is one of the world's most widely used personal music management systems. Using RealJukebox, you can capture the contents of a music CD, manage and play back your music, and view various music-related information via the Internet. This Custom RealJukebox for Sony allows seamless check-out capabilities to a wide range of Sony personal audio devices, and offers convenient links to Sony product and music service home pages.



If you are using an external CD-ROM drive connected with a PC Card, be sure to connect your external CD-ROM drive before starting RealJukebox. Additionally, do not remove your CD-ROM drive while using RealJukebox. Either of these actions may cause RealJukebox to shut down improperly.

Sony recommends using the preinstalled SonicStage software's Record function to create any CDs on your VAIO® computer, if the specific model you purchased is preconfigured with all necessary components for CD-R and CD-RW capability. Downloading the optional RealJukebox CD-burning component to create any CDs on your computer may interfere with normal system operations.

RealPlayer®

RealNetworks Inc.

RealPlayer is the RealNetworks video and audio player which lets you access 2,500 radio stations featuring music, news, and sports.

Smart Capture

Sony Electronics Inc.

Smart Capture is a fun new way to send multimedia messages via e-mail. Smart Capture manages the i.LINK®* connection between your computer and a Sony Digital Handycam® Camcorder that supports the i.LINK interface. It allows you to capture compressed video or still images that you can save or share via e-mail. A smart solution to computer, digital audio/video and network convergence.

* i.LINK is a trademark of Sony used only to designate that a product contains an IEEE1394 connection. The i.LINK connection may vary, depending on the software applications, operating system and compatible i.LINK devices. All products with an i.LINK connection may not communicate with each other. Refer to the documentation that came with your compatible i.LINK device for information on operating conditions and proper connection. Before connecting compatible i.LINK PC peripherals to your system, such as a CD-RW or hard disk drive, confirm their operating system compatibility and required operating conditions.

Smart Capture Premium

Sony Electronics Inc.

Sony's Smart Capture Premium application supports still image and video capture from the built-in Sony MOTION EYE™ camera, an analog Video In device such as a VCR, TV, or Playstation®, or a digital video device connected to the PC through an i.LINK or USB interface. Transfer your compressed video or still images through e-mail, upload them to the ImageStationSM service, or export to MovieShaker™ software for further video editing fun.

SonicStage

Sony Electronics Inc.

This new jukebox application adds a host of new features to its predecessor, OpenMG™ Jukebox. Continuing to take advantage of Sony's copyright-protected ATRAC3™ format for high-quality digital audio storage, SonicStage sports a new Music Visualizer, a sleek new player skin design, audio CD burning capability, and a parametric equalizer for fine-tuning audio playback.

Sony on Yahoo!

Yahoo! Inc.

Personalize your own web portal with Sony on Yahoo! Get a free webmail account, customized news and local weather reports, comics, and more.

VAIO Action Setup

Sony Electronics Inc.

VAIO Action Setup manages the settings for your computer's Jog Dial control and i.LINK interface.

VAIO Support Agent

Sony Electronics Inc.

VAIO Support Agent provides immediate, interactive online support.

VisualFlow™

Sony Electronics Inc.

VisualFlow software is a state-of-the-art Sony multimedia browser designed specifically for Memory Stick® media. It displays any still picture, movie, or sound file stored in a Memory Stick® media in a visually pleasing, artistic manner. VisualFlow software not only plays a selected movie or sound file, but also enables playback of files by other applications such as PictureGear™, Memory Stick Slideshow, and Windows® Explorer.

WinDVD®

InterVideo Inc.

WinDVD is a simple-to-use DVD player including all the features you would expect to find in a standard consumer DVD player, while also offering advanced display and navigation features such as zoom, pan, bookmark, and time search.

DVgate application notes

Digital video captures

If your system displays the message, “Failed to record to DV deck, please check deck’s power status, cable connection...,” while you are recording images to a digital video device using DVgate software, close all open applications, and restart your computer. Frequent recording of images to a digital video device while using DVgate may cause this situation to occur.

For more information on DVgate software, see the DVgate online help.

Adjusting image resolution

If the images on the LCD do not display smoothly, the resolution may not be set correctly. To check the resolution, click the Setup button in the DVgate Motion-Monitor window. Point to Settings, and then select Low Resolution. The settings you change in this menu affect the images in the monitor window only. Movie data imported to your hard drive and images recorded to DV devices will not be affected.

Hard disk drive partition

In order to improve the performance of your computer’s DVgate™ motion software, the hard disk drive on your computer has been formatted with two partitions, C and D. The C partition hold 40 percent and the D partition holds 60 percent of the entire drive capacity. DV gate software saves files to the D partition. This prevents large video capture from consuming the available space on your C partition. To maintain optimum performance of DVgate, you should defragment or format the D partition regularly.

To defragment a partition



Before you begin to defragment a partition, make sure you back up all files that you want to save.

- Click the Start button in the Windows® taskbar.
- Click Programs, Accessories, System Tools, and then click Disk Defragmenter. The Disk Defragmenter window appears.

Select the drive you want to defragment from the list, and click the Defragment button. See Windows® Help for more information on defragmenting.

Application, Driver, and System Recovery CDs

Your computer is supplied with the following application, driver, and system recovery CDs. To use your recovery CDs, see “Using Your Recovery CDs” for more information.

Application Recovery CD(s)

Sony Electronics Inc.

This CD enables you to reinstall individual applications if they become corrupted or are erased.

Driver Recovery CD(s)

Sony Electronics Inc.

This CD enables you to reinstall individual device drivers if they become corrupted or are erased.

System Recovery CD(s)

Sony Electronics Inc.

This CD enables you to format the C:\ partition of the hard disk drive, then reinstall the operating system and software titles that shipped with your computer, if they become corrupted or are erased. Use it to restore the hard disk of the VAIO® computer you purchased. This CD restores your computer to its original state, so user data and applications will be lost.

Using Your Recovery CDs

The following sections describe how to use the Application Recovery, Driver Recovery, and System Recovery utilities. You must connect an optional optical disc drive to use the Application, Driver, and System Recovery CDs.

To use the Application Recovery CD(s)

The Application Recovery CD(s) allows you to reinstall individual applications if they become corrupted or are accidentally erased. Reinstalling an individual software title may correct a problem you are experiencing with your computer or software application; you may not need to reinstall the entire contents of your hard disk drive. If you need to reinstall all the software titles that shipped with your computer, use the System Recovery CD(s). See “To use the System Recovery CD(s)” for more information.

 You must be in Windows® to run the Application Recovery CD. If you have any questions on using the Application Recovery CD, contact Sony Customer Support.

- 1** Turn on your computer. If your computer is already on, close all applications.
- 2** When the Windows desktop appears, insert the Sony Application Recovery CD in the optical drive. The Application Recovery utility loads automatically.
- 3** When the Application Recovery menu appears, select the icon for the application you want to restore and then follow the on-screen instructions to complete the recovery process.

 Your system may include one or two Application Recovery CDs. If you have two Application Recovery CDs, insert the first CD to run the Application Recovery program. You may be prompted to insert the second CD, depending on the application you wish to restore.

To use the Driver Recovery CD(s)

The Driver Recovery CD utility enables you to reinstall individual drivers and repair software applications if they become corrupted or are erased. You can reinstall an individual driver to correct a problem that you are experiencing with

your computer, hardware, or software application. VAIO Support Agent, an application repair utility, uses a vault feature on the Driver Recovery CD during its software healing process.

 If you need to reinstall all of the software applications that shipped with your computer, use the System Recovery CD.

You must be in Windows® to run the Driver Recovery CD utility.

Reinstalling specific drivers with the Driver Recovery CD

- 1** Turn on your computer. If your computer is already on, close all applications.
- 2** When the Windows desktop appears, insert the Driver Recovery CD into the optical disc drive.
- 3** Click Start in the Windows taskbar, then Control Panel. The Control Panel window appears.
- 4** Click Performance and Maintenance, then System. The System Properties dialog box appears.
- 5** From the Hardware tab, click Device Manager.
- 6** Click with the left mouse button to highlight the device for which you wish to reinstall the driver.
- 7** From the Actions menu, choose Properties. Properties dialog box for that device appears.

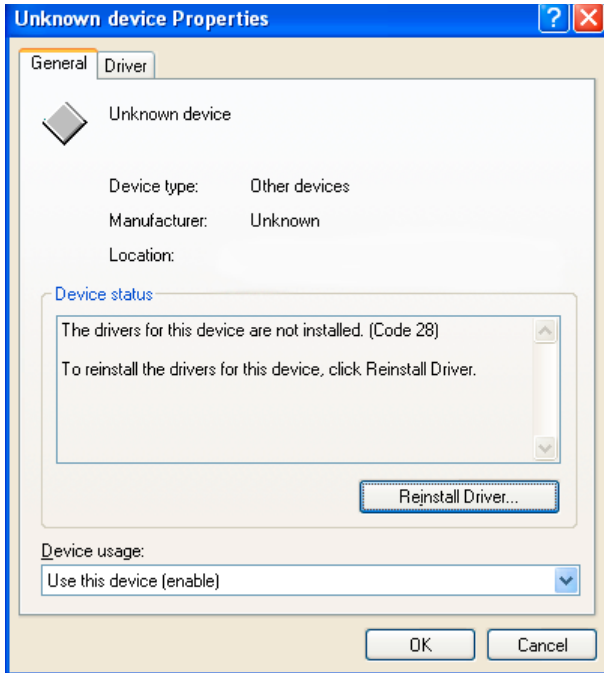
Properties dialog box

- 8 Click Reinstall Driver. The Hardware Update Wizard appears.
- 9 Click Next. The wizard will search for the correct driver on your Driver Recovery CD.
- 10 When the recovery process is complete, click Finish. Some drivers will require that you reboot the computer to complete installation.

To use the System Recovery CD(s)

This CD restores your computer to its original state, so user data and applications will be lost.

You can use the System Recovery CD(s) to reinstall the operating system and software titles that shipped with your computer if they become corrupted or erased. You may not need to reinstall the entire contents of your hard disk drive. If you experience a problem with your computer, reinstalling an individual device driver or software title may correct the problem. Use the Application Recovery CD(s) to reinstall individual applications or use the Driver Recovery CD(s) to reinstall device drivers. See “To use the Application Recovery CD(s)” for more information.

The System Recovery CD contains a backup copy of all the software originally installed on your hard disk drive. It can be used only to recover the hard disk of the computer you purchased.

The System Recovery utility will perform a Full Restore with Format. It formats the hard disk drive, then restores all the original software.



Full Restore with Format removes all the information on the hard disk drive. You will lose any software you have installed and any other files you have created since you started to use your computer. This means you will have to reinstall any applications that were not included with the computer when you purchased it. If you have any questions on using the System Recovery CD, contact Sony Customer Support.

- 1 Insert the Sony System Recovery CD in the optical drive.
- 2 Shut down your computer as described in the “Shutting Down Your Computer” section of your printed Quick Start.
- 3 Wait four seconds and turn on your computer.
- 4 Select OK to signify you have read and accept the Microsoft® End-User License Agreement.
- 5 When the System Recovery menu appears, follow the on-screen instructions to complete the recovery process.

If your computer does not start from the Recovery CD

- 1 Press the power button and hold it for more than four seconds to turn off the computer.
- 2 Turn on the computer. When the Sony logo is displayed, press the F2 key. The BIOS setup menu screen appears.

- 3 Press the arrow keys to select the Exit menu.
- 4 Press the arrow keys to select “Get Default Values” and then press the Enter key. The message “Load default configuration now?” appears.
- 5 Check that “Yes” is selected, then press the Enter key.
- 6 Press the arrow keys to select “Exit” (Save Changes) and then press the Enter key. The message “Save configuration changes and exit now?” appears.
- 7 Check that “Yes” is selected, then press the Enter key. The computer restarts from the Recovery CD.

 Your system may include one or more System Recovery CDs. If you have two System Recovery CDs, insert the first CD to run the System Recovery program. You are prompted to insert the next CD once the information from the previous CD has been installed.

The recovery process takes from 30 minutes to 60 minutes to complete.

After recovering your system using the System Recovery CD(s), you may be prompted to insert your Application Recovery CD(s) after restarting Windows. Insert the Application Recovery CD to automatically complete recovery of your system.

Recovering Microsoft Word

If you recover your operating system using the System Recovery CD, Microsoft® Word will not be recovered. Use the supplied Word CD-ROM to recover this application. The basic version of Word is preinstalled; you may load other Word options from the Word Application CD.

Troubleshooting

This section describes how to solve common problems you may encounter when using your computer. Many problems have simple solutions, so try these suggestions before you contact Sony Computing Support (<http://www.sony.com/pcsupport>).

- ❑ Troubleshooting Your Computer
- ❑ Troubleshooting the LCD Screen
- ❑ Troubleshooting the Mouse and Pointing Device
- ❑ Troubleshooting Drives, PC Cards and Peripheral Devices
- ❑ Troubleshooting i.LINK devices
- ❑ Troubleshooting Software
- ❑ Troubleshooting the Modem
- ❑ Troubleshooting Audio
- ❑ Troubleshooting Memory Stick Media

Troubleshooting Your Computer

My computer does not start.

- ❑ Check that the computer is plugged into a power source and that it is turned on. Check that the power indicator on the front panel of the computer indicates that the power is on.
- ❑ Check that the battery pack is inserted properly and is charged.
- ❑ If you have connected an external floppy disk drive, make sure there is no floppy disk in the floppy disk drive.
- ❑ Confirm that the power cord and all cables are connected firmly. See “Connecting Peripheral Devices” for more information.
- ❑ If you plugged the computer into a power strip or Uninterruptible Power Supply (UPS), make sure the power strip or UPS is turned on and working.
- ❑ If you are using an external display, check that it is plugged into a power source and turned on. Check that the brightness and contrast controls are adjusted correctly. See the manual supplied with your display for details.
- ❑ Condensation may cause the computer to malfunction. If this occurs, do not use the computer for at least one hour.
- ❑ Take the battery pack off the computer, unplug the power cord and plug it in again, then turn on the power.

 If this occurs on a regular basis, contact Sony Computing Support at: <http://www.sony.com/pcsupport/>.

My computer starts, but a BIOS error appears.

- ❑ When the computer’s internal backup battery is low on power, it may not start your system properly. The message “Press <F1> to resume, <F2> to setup” appears at the bottom of the screen. Follow these steps:
 - 1 Press the F2 key. The BIOS Setup menu appears.
 - 2 Set the date (month/day/year). Press Enter.
 - 3 Press ↓ to select System Time, then set the time (hour: minute: second). Press Enter.
 - 4 Press → to select Exit, then press ↓ to select Get Default Values. The message “Load default configuration now?” appears.

- 5 Select Yes and press Enter.
- 6 Select Exit (Save Changes), and then press Enter. The message “Save configuration changes and exit now?” appears.
- 7 Select Yes, and then press Enter. The computer restarts.

My computer starts, but the message “Operating system not found” appears and Windows does not start.

- ❑ If you have connected an external floppy disk drive, make sure there is no floppy disk in the floppy disk drive (non-bootable).
- ❑ If a non-bootable disk is in the drive, follow these steps:
 - 1 Turn off the computer, and then remove the floppy disk.
 - 2 Restart the computer and confirm that Windows starts properly.
- ❑ If Windows still does not start, follow the steps below to initialize the BIOS:
 - 1 Remove any disk from the floppy disk drive.
 - 2 Remove any peripheral devices connected to the computer.
 - 3 Turn off the computer and then turn it on.
 - 4 Press the F2 key when the Sony logo appears. The BIOS setup menu screen appears.
 - 5 Press the directional arrow keys to select the Exit menu.
 - 6 Press the arrow keys to select “Get Default Values” and then press Enter. The message “Load default configuration now?” appears.
 - 7 Select Yes, then press Enter.
 - 8 Use the directional arrow keys to select “Exit” (Save Changes), and then press Enter. The message “Save configuration changes and exit now?” appears.
 - 9 Select Yes, then press Enter. The computer restarts.

If your computer continues to display the message “Operating system not found,” and Windows does not start, contact Sony Computing Support.

My computer stops responding or does not shut down.

It is best to shut down your computer using the Turn Off Computer command on the Windows Start menu. Using other methods, including those listed here, may result in loss of unsaved data.

- ❑ Try restarting the computer. On the Windows taskbar, click the Start button, click Turn Off Computer, and then click Restart.
- ❑ If you cannot restart as described in the preceding step, you can restart the computer by pressing the Ctrl+Alt+Delete keys at the same time.
- ❑ If the previous step does not work, press and hold the power button for at least four seconds. This turns off the power to the computer.
- ❑ If your computer stops responding while playing a CD or DVD, stop the CD/DVD, and restart the computer by pressing the Ctrl+Alt+Delete keys at the same time.
- ❑ Unplug the computer from the AC adapter and remove the battery pack from your computer.

 Pressing the Ctrl+Alt+Delete keys or turning off the computer with the power switch may result in data loss in files that are currently open.

The Power Management setting is not responding.

Your computer's operating system may become unstable if it is interrupted or if you attempt to make changes before the computer completely enters a lower power mode, such as Hibernate.

- ❑ To restore the computer to its normal operating stability:
 - 1 Close all open applications.
 - 2 Restart the computer by pressing the Ctrl+Alt+Delete keys at the same time, and then selecting Restart from the drop-down list.

 If this procedure does not work, press and hold the power button for at least four seconds to shut down the computer.

The sound of my computer's fan is too loud.

Use the PowerPanel™ utility to change the Thermal Control Strategy setting to Quiet. This setting slows down the CPU speed. See PowerPanel Help for more information.

Why does the System Properties dialog box display a slower CPU speed than advertised?

This is normal. Because your computer's CPU utilizes a type of CPU speed controlling technology, System Properties may display the CPU's current speed instead of the maximum advertised speed.

Troubleshooting the LCD Screen

My LCD screen is blank.

- Check that the computer is plugged into a power source and that it is turned on.
- Check that the power indicator on the computer is on.
- Check that the battery pack is inserted properly and that it is charged.
- The computer may be in LCD (Video) Standby mode. Press any key to activate the screen.
- The display mode may be set to external display mode. Press and hold the Fn key while pressing F7 several times.

The image on my connected external display is not centered or sized properly.

Use the controls on your external display to adjust the image. See the manual supplied with your display for more information.

I cannot simultaneously display movies, DVD video, or the Smart Capture (Finder) window on the LCD display and an external display.

Images cannot be displayed on both the LCD display and an external display at the same time. Select only one display option.

I want to change the video resolution of my display.

You can use independent controls to change the video resolution of your display.

- Click Start, point to Control Panel, point to Appearance and Themes, and then click the Display icon. The Display Properties dialog box appears.
- Click on the Settings tab.
- Move the Screen Area slider to change your video resolution.

Troubleshooting the Mouse and Pointing Device

My mouse does not work.

- ❑ If you are using an external mouse, check that the mouse cable is plugged into the USB port. See “Connecting a USB Mouse” for details. Note that a serial mouse or PS/2® mouse is not compatible with the VAIO® C1 PictureBook® computer.
- ❑ If you connect an external mouse while your computer is on, you must restart your computer.
- ❑ If you are using an optional Sony USB mouse, such as the PCGA-UMS1 series, check that the mouse is plugged into the USB port.
- ❑ Re-install the mouse/touchstick drivers. See “Using Your Recovery CDs” for more information.

My pointing device does not work properly.

- ❑ You may have disabled the pointing device without a mouse being connected to the computer. You must restart the computer to make the pointing device work again.
- ❑ If your pointing device is interpreting a single tap as a double-click, you must adjust the button assignments. Follow these steps:
 - 1 Click Start, point to Control Panel, point to Printers and Other Hardware, and then click on the Mouse icon.
 - 2 Change the button assignments in the Mouse Properties dialog box. (One of the buttons is assigned to the double-click action.)
- ❑ Reinstall the mouse/touchstick drivers. See “Using Your Recovery CDs” for more information.

The pointer does not move (while using the pointing device or mouse).

- ❑ Press the Windows key on the keyboard, and press the “U” key to select Turn Off Computer. When the “Turn off computer” dialog box appears, press the “R” key to restart the computer.
- ❑ If you cannot turn off your computer as described in the step above, press the Ctrl+Alt+Delete keys (at the same time) to restart the computer.

- ❑ If you cannot restart your computer as described in the step above, press and hold the power button for at least four seconds to turn off the computer.
- ❑ If the pointer does not move while playing a disc, press the Ctrl+Alt+Delete keys (at the same time) to stop playback and restart the computer.

Troubleshooting Drives, PC Cards and Peripheral Devices

My floppy disk drive icon doesn't appear even though it is connected.

- ❑ Make sure that the floppy disk drive is properly connected. Wait a few moments to allow the computer to recognize the drive.
- ❑ Close all open applications and restart your computer with the connected floppy disk drive. Make sure that there is no floppy disk in the floppy disk drive, in order for the computer to start up correctly.

My optical drive is not playing my disc properly.

- ❑ Make sure the optical drive is inserted correctly into the PC Card slot or i.LINK port.
- ❑ Make sure the label of the disc is facing up.
- ❑ If the disc requires software, make sure the software is installed according to the manufacturer's instructions.
- ❑ A dirty or damaged disc may cause the computer to stop responding while it tries to read the disc. If necessary, restart the computer, remove the disc, and then check it for dirt or damage.
- ❑ If you see video but can not hear audio, check all of the following:
 - ❑ Check that your optical drive does not have the mute setting enabled.
 - ❑ Check the volume setting in the audio mixer.
 - ❑ If you are using external speakers, check the volume settings, and then check the connections between your external speakers and the computer.
 - ❑ Click Start, point to Control Panel, click Performance and Maintenance, then click System, select Hardware, and click Device Manager. Check that the correct drivers are installed properly.
- ❑ Check that digital CD audio is enabled for your optical drive. Do the following steps:
 - 1 Click Start, point to Control Panel, click Performance and Maintenance, and then click System. The System Properties window appears.

- 2 Select the Hardware tab and then click the Device Manager button. The Device Manager window appears.
 - 3 Double-click the DVD/CD-ROM drive name. The Properties window appears.
 - 4 Click the Properties tab, and then select the “Enable digital CD audio for this CD-ROM device” check box.
- Do not use adhesive labels to identify the CD. The label may come off while the disc is in use in the optical drive and cause the drive to malfunction.
 - If a region code warning appears when you try to use a DVD-ROM drive, it may be that the DVD you are trying to play is incompatible with the DVD-ROM drive. Check the region code listing on the DVD packaging.
 - Condensation may cause the computer to malfunction. If this occurs, do not use the computer for at least one hour.

My optical disc drive tray does not open.

- Make sure the computer is turned on.
- Press the Eject button on the optical drive.
- If the Eject button does not work, you can open the tray by inserting a long, thin object (such as a straightened paper clip) into the hole to the right of the Eject button.

I cannot use digital video (DV) devices. The message “DV equipment seems to be disconnected or turned off” appears.

- Check that the DV device is turned on and that the cables are properly connected.
- Disconnect the i.LINK® cable and connect it again.

My PC Card is not working.

- Make sure the PC Card is inserted properly into the PC Card slot.
- Make sure the PC Card is compatible with Microsoft® Windows®.
- Use the Sony Notebook Setup utility to disable devices you are not currently using.

Troubleshooting i.LINK devices

I cannot establish a connection between two VAIO computers when using an i.LINK cable.

- 1 Disconnect the i.LINK®* cable from both computers and reconnect it.
- 2 Wait for the computers to respond. If neither computer responds after a few moments, restart both computers.

 The computers may not recognize an i.LINK connection after returning from a power saving mode (Standby or Hibernate). If that happens, restart the computers to establish a connection.

* i.LINK is a Sony trademark used only to designate that a product contains an IEEE 1394 connection. The i.LINK connection may vary, depending on the software applications, operating system, and compatible i.LINK devices. All products with an i.LINK connection may not communicate with each other. Refer to the documentation that came with your compatible i.LINK device for information on operating conditions and proper connection. Before connecting compatible i.LINK PC peripherals to your system, such as a CD-RW or hard disk drive, confirm their operating system compatibility and required operating conditions.

Troubleshooting Software

My software program stops responding or crashes.

Contact the software publisher or designated provider for technical support. See the “About the Software on Your Computer” section for more information.

When I click an application icon, the message “You must insert the application CD into your CD-ROM (DVD-ROM) drive” appears, and the software does not start.

- Make sure that your optical drive is connected to your computer.
- Some titles require specific files that are located on the application CD. Insert the disc and try starting the program again.
- Make sure you place the CD in the tray with the label side facing up.

I cannot use the DVgate software.

If your computer is using the Ultimate Battery Life profile for its power saving mode, you cannot use DVgate or Smart Connect software. Please select another profile.

My computer’s start-up time seems longer after I have installed AOL. What can I do?

On some computers, installing America Online® (AOL) may increase boot time by up to a minute. If you experience this on your system and would like to speed up the time required to start your computer, you may want to disable the AOL WAN driver. Do the following:

- 1 Click Start in the Windows® taskbar and select Control Panel.
- 2 Click Network and Internet Connections, and select Network Connections.
- 3 Right-click on the Local Area Connection with device name “WAN Network Driver,” and select Disable.

Verify that your AOL connection still functions satisfactorily with the WAN Network Driver disabled. If you need to reverse this setting, repeat the steps above and select Enable.

What software do I use for CD-R/CD-RW software functions?

Sony recommends using the preinstalled SonicStage software's Record function to create any CDs on your VAIO® computer, if the specific model you purchased is preconfigured with all necessary components for CD-R and CD-RW capability.

Downloading the optional RealJukebox CD-burning component to create any CDs on your computer may interfere with normal system operations.

The image does not display properly in Smart Capture Premium.

If you use the AV In port and Smart Capture Premium software to record an image, the image may become distorted. Use Windows® Media Player software to correct this problem. Follow the procedure below.

- 1 Close Smart Capture Premium software.
- 2 Click Start on the Windows taskbar, select All Programs, and click Windows Media Player. The Windows Media Player window appears.
- 3 Select File and click Open. When the Open dialog box appears, click My Documents in the left menu.
- 4 Double-click Smart Capture Premium. If you created a folder to save the image, open the folder you created.
- 5 Double-click the folder you want to play.

Why doesn't the Bluetooth destination button in the send mode of Smart Capture Premium function?

The Bluetooth™ destination button does not function because your computer does not support Bluetooth technology. To send images, use the Mail, ImageStation, or MovieShaker button as an alternative. You may refer to the online Help for Smart Capture Premium for more information. To access the online help file, click Start on the Windows taskbar, select All Programs, select Smart Capture Premium, and click Smart Capture Premium Online Help.

Troubleshooting the Modem

My modem does not work.

- ❑ Check that the phone line is plugged into the line jack. See “Connecting a Phone Line” for details.
- ❑ Check that the phone line is working. You can check the line by plugging in an ordinary phone and listening for a dial tone.
- ❑ Check that the phone number the program is dialing is correct.
- ❑ Check that the software you are using is compatible with the computer’s modem. (All preinstalled Sony programs are compatible.)
- ❑ Reinstall the modem driver. See “Using Your Recovery CDs” for more information.

My modem connection is slow.

Your computer is equipped with a V.90/K56flex-compatible modem. Many factors may influence modem connection speed, including telephone line noise or compatibility with telephone equipment (such as fax machines or other modems). If you think your modem is not connecting properly to other PC-based modems, fax machines, or your Internet Service Provider, check the following:

- ❑ Have your phone company check that your phone line is free from any line noise.
- ❑ If your problem is fax-related, check that there are no problems with the fax machine you are calling and that it is compatible with fax modems.
- ❑ If you are having a problem connecting with your Internet Service Provider, check that the ISP is not experiencing technical problems.
- ❑ If you have a second phone line available, try connecting the modem to that line.

Troubleshooting Audio

My speakers have no sound.

- ❑ If the built-in speakers are turned off, press the Fn+F3 keys to turn on the speakers. You can also turn on the speakers using the Jog Dial control.
- ❑ If the speaker volume is turned to the minimum, press the Fn+F4 keys, and then press **↑** or **→** to increase the volume or you can use the Jog Dial control to control the volume.
- ❑ If nothing is displayed when you press the Fn+F3 or Fn+F4 keys, then:
 - 1 Click Start, point to Control Panel, click “Sounds, Speech, and Audio Devices,” and click “Sounds and Audio Devices.” The Sounds and Audio Devices Properties dialog box appears.
 - 2 Verify that the Mute box has not been checked, and that the volume is not on the lowest setting. You can choose advanced options to customize audio settings.
- ❑ If your computer is battery-powered, check that the battery pack is inserted properly and that it is charged.
- ❑ If you are using an application that has its own volume control, check that the volume is turned up.
- ❑ Check the volume controls in Windows®.
- ❑ If you connect external speakers, check that the speakers are properly connected and the volume is turned up. If the speakers have a mute button, make sure it is off. If the speakers are powered by batteries, check that the batteries are inserted properly and that they are charged.
- ❑ If you have connected an audio cable to the Headphone jack, disconnect the cable.

There is noise distortion while listening to music with USB speakers or USB headphones.

Use the preinstalled PowerPanel™ software to set the CPU control to Performance. Do the following:

- 1 Right-click the CPU icon on the bottom right of the taskbar, and click “Edit/create profiles. The Profile editor window appears.
- 2 In the left portion of the window, click the power management profile you want to set. Maximum Battery Life is the default selection when your computer runs on battery power.
- 3 In the right portion of the window, double-click CPU Control. The list of CPU control options appears.
- 4 Click Performance.
- 5 Click the File menu and select Save.
- 6 Close the Profile Editor window.

My microphone does not work.

If you are using an external microphone, check that the microphone is plugged into the Microphone connector. See “Connecting an External Microphone” for details.

Troubleshooting Memory Stick Media

Image files do not open even though I insert Memory Stick media into the slot.

- ❑ By the default setting, VisualFlow™ software starts automatically when you insert Memory Stick® media into the slot.
- ❑ If VisualFlow software is active and the image files in Memory Stick media are not displayed, the format type of the Memory Stick media can be different.
- ❑ Copy the data from the Memory Stick media onto the hard disk drive of your computer and then format the Memory Stick media using Memory Stick Formatter software preinstalled on your computer.

Memory Stick media does not work. I cannot access the removable drive.

- ❑ If you cannot find the Memory Stick icon in My Computer, click the View drop-down menu and select Refresh. Wait a few moments to recognize the Memory Stick media. Click the Memory Stick icon to view any possible contents.

Getting Help

Sony provides you with several support options to answer questions about your VAIIO® computer or the preinstalled software. Refer to these resources in the order they are listed.

Support Options

- 1 VAIO® User Guide and VAIO® Quick Start**
The online VAIO® Computer User Guide and printed VAIO® Computer Quick Start provide you with information on how to maximize your computer capabilities and solve common problems. To access the online user guide, click Start on the Windows® taskbar, select Help and Support, and click on VAIO User Guide. The Quick Start is supplied in the box with your computer.

 - 2 Manuals and Online Help Files**
The software preinstalled on your computer may come with an online manual. These manuals are stored on the hard disk drive as online help files. You can find the help files from the Help menu under the specific software application. Some software applications may come with a printed manual.

 - 3 Operating System Online Support**
Your computer comes preinstalled with Microsoft® Windows®. For operating system support, access Sony Computing Support at:
<http://www.sony.com/pcsupport>.

 - 4 VAIO Support Agent**
You can find VAIO Support Agent by clicking Start and then selecting Help and Support. Using advanced diagnostic technology, Sony's VAIO Support Agent runs scheduled protections of your applications, network settings, and other important software settings. When your software is protected, you can use VAIO Support Agent to repair software problems by restoring your software to any of the previously protected states.

 - 5 Sony PC Support**
This service provides you with instant access to information on commonly encountered problems. Enter a description of your problem and the Knowledge Database searches for the corresponding solutions online. You can access Sony Computing Support at:
<http://www.sony.com/pcsupport>.
-

6 Sony Fax-on-Demand

This service, which requires a fax machine or your fax software, provides answers to commonly asked questions. You can use this automated service to request a list of available topics, then select the topics that you want to receive. To contact the Sony fax-on-demand service, call: 1-888-4-SONY-PC (1-888-476-6972).

7 Sony Customer Support

Software support is available free of charge for 90 days after the original date of purchase. You can call and speak with a Sony Customer Support Representative without using your computer by calling: 1-888-4-SONY-PC (1-888-476-6972).

Software Support Information

Adobe Acrobat® Reader™, Photoshop® Elements (Adobe Systems, Inc.)

Web site	http://www.adobe.com/
phone	206-675-6126 (fee-based support)
e-mail	techdocs@adobe.com
hours	M-F, 6 AM-5 PM PST

America Online® (America Online, Inc.)

Web site	http://www.aol.com
phone	800-827-3338
hours	7 days a week, 24 hours a day

Apple QuickTime™ (Apple Computer Inc.)

Web site	http://www.apple.com
phone	800-692-7753
hours	7 days a week, 24 hours a day

EarthLink™ Network Total Access (EarthLink Network Inc.)

Web site	http://help.earthlink.net/techsupport/
e-mail	support@earthlink.net
phone	800-890-5128, 800-890-6356
hours	7 days a week, 24 hours a day

PhotoPrinter® 2000 Pro (ArcSoft, Inc.)

Web site	http://www.arcsoft.com
e-mail	support@arcsoft.com
phone	510-440-9901
fax	510-440-1270
hours	M-F 8:30 AM - 5:30 PM PST

PC-Cillin® 2000 (Trend Micro, Inc.)

Web site	http://www.antivirus.com/pc-cillin/
phone	949-387-7800
e-mail	support@trendmicro.com
hours	M - F 8 AM - 5 PM (PST)

Quicken® (Intuit Inc.)

Web site	http://www.intuit.com/support
phone	800-644-3193
hours	7 days a week, 24 hours a day

RealJukebox®, RealPlayer (Real Networks, Inc.)

Web site	http://service.real.com/rjoptions.html
e-mail	http://service.real.com/help/call.html

Sony Applications (Sony Electronics Inc.)

Web site	http://www.sony.com/pcsupport
phone	888-4-SONY-PC (888-476-6972)*
hours	7 days a week, 24 hours a day

* Support from 1-888-4-SONY-PC is free of charge for 90 days after the original date of purchase.

Windows® Operating System, Internet Explorer, Word (Microsoft Corp.)

Web site	http://www.sony.com/pcsupport
phone	888-4-SONY-PC (888-476-6972)*
hours	7 days a week, 24 hours a day

* Support from 1-888-4-SONY-PC is free of charge for 90 days after the original date of purchase.

WinDVD® (InterVideo, Inc.)

Web site	http://www.intervideo.com
phone	510-651-0888

Sony Service Center

For the Sony Service Center nearest you, call 1-888-4-SONY-PC (1-888-476-6972) or find Sony Computing Service on the Web at: <http://www.sony.com/pcsupport>.

A

About This Computer tab 79

AC power setting 82

adding

 hardware 47

 memory 91

 peripherals 47

 printers 67

adjusting

 brightness 18

 volume 18

Alt key 14

Application Recovery CD 109

Applications key 14

audio

 adjusting volume 18

 troubleshooting 129

Audio tab 79

AV In 40

AV Out 40

B

battery packs

 charge status icons 85

 conserving battery power 84

BatteryScope utility 85

brightness

 adjusting 18

built-in speaker 18

 volume 18

buttons

 Start (Windows) 78

C

camera

 built-in 20

 digital video camcorder 61

 notes on 24

canceling commands 13

Caps Lock

- indicator light 17
- CD or DVD discs
 - cleaning 54
 - handling 54
 - inserting 52
- CD-ROM drive
 - closing lid 53
 - connecting 37, 51
 - using 51
- cleaning
 - CD or DVD discs 54
- coin-operated telephones 44
- computer
 - connecting to another 59
 - expanding capabilities 74
 - setup screen 78
- Connecting
 - Ethernet 45
 - LAN 45
- connecting
 - another VAIO computer 59
 - CD-ROM drive 37, 51
 - coin-operated telephones 44
 - digital video recorder 61
 - external display 63
 - external mouse 58
 - external speakers 73
 - floppy disk drive 48
 - i.LINK device 60
 - i.LINK optical disc drive 55
 - microphone 68
 - monitor 63
 - multiple phone lines 44
 - network 37
 - party phone lines 44
 - PBX 44
 - phone line 43
 - printer 67
 - projector 64

TV 65

connectors

- printer 67

correction keys 13, 14

Ctrl key 14

cursor-movement keys 13

D

digital video camera 61

display

- connecting an external 63
- mode 89

Driver Recovery CD 109

drives 51

- CD-ROM 51
- floppy disk 48
- optical 51
- troubleshooting 123

DV In/Out 61

DVD-ROM drive tray

- troubleshooting 124

DVgate applications 106

E

Eject button 49

ejecting

- floppy disks 49

Escape key 13

Ethernet port 40

expanding notebook capabilities 74

external

- display 63
- microphone 68
- mouse 58
- speakers 73

F

floppy disk drive

- connecting 48
- disconnecting 38, 49

floppy disks

- ejecting 49
- handling 50
- inserting into drive 49

- Fn key 14
 - combination commands 18
- function keys 13, 14

G

- Guide mode 30

H

- handling
 - CD or DVD discs 54
 - floppy disks 50

- hardware
 - online support 134

- headphone connector 65

- help
 - getting 133

- Hibernate mode 19, 41

I

- i.LINK 61
 - connecting an i.LINK device 60
 - notes on 61

- i.LINK optical disc drive
 - connecting 55
 - notes on 57

- IEEE 1394 61

- indicator lights
 - Caps Lock 17
 - Num Lock 17
 - Scroll Lock 17

- Insert key 13, 14

- inserting
 - CD or DVD discs 52
 - floppy disks into drive 49

- installing
 - hardware 47
 - memory 37
 - peripherals 47

J

Jog Dial control 29

K

keyboard 18
using 12–15

L

LAN

connecting to 45

Launcher mode 29

LCD

troubleshooting 120

M

MagicGate 33

Maximum Battery Life power setting 82

Maximum Performance power setting 82

memory

adding 91

confirming added capacity 97

removing 93

memory module

installing 37

Memory Stick

notes on 36

troubleshooting 131

using 33

VisualFlow 35

Memory Stick card slot 34

Memory Stick media

displaying contents 34

microphone

external 68

troubleshooting 130

modem

troubleshooting 128

monitor

connecting 63

switching among 18

MOTION EYE camera

- notes on 24
- using 20

mouse

- connecting 58
- troubleshooting 121

multiple phone lines 44

N

navigation keys 13

network

- connecting 37

Notebook Setup tabs 79

Num Lock

- indicator light 17

numeric keypad area 13

O

operator keys 14

output devices

- adding 67

P

party phone lines 44

PBX 44

PC Card

- inserting 37

- removing 38

- troubleshooting 123

- Type II 37

- using 37

- Wireless LAN 75

PDA 74

peripheral devices

- troubleshooting 123

Personal Digital Assistant 74

phone

- connecting line 43

- jack 43

pointing device

- replacing the cover 27

- troubleshooting 121

- using 26
- ports
 - USB 48
- Power Management
 - commands 84
 - profiles 81
- power management
 - settings 80
- Power Management Off power setting 82
- Power On
 - Password tab 79
- power saving modes
 - Hibernate 19, 41
 - Standby 18, 41
- power setting
 - AC 82
 - Maximum Battery Life 82
 - Maximum Performance 82
 - Power Management Off 82
 - Standby 84
 - Video Standby 84
- PowerPanel
 - activating 80
 - customizing toolbar 82, 84
- Print Screen key 13
- printer
 - connecting 67
 - port 67
- projector 64
- R**
- Recovery CD 109
- removing
 - floppy disk drive 38, 49
 - floppy disks 49
 - memory module 93
- restoring data 109
- S**
- Scroll Lock

- indicator light 17
- setting up your PC
 - support 134
- setup screen
 - About This Computer tab 79
 - Audio tab 79
 - displaying 78
 - Power On Password tab 79
- setup tabs 79
- Shift key 14
- software
 - descriptions 100
 - DVgate 106
 - troubleshooting 126
 - using the Jog Dial control with 31
- Sony Fax-on-Demand service 135
- Sony Notebook Setup screen 78
- Sony Service Center 137
- speakers
 - connecting 73
 - troubleshooting 129
- Standby mode 18, 41, 84
- Start button 78
- support options 133
- switching
 - display 18
 - monitor 18

T

- television
 - connecting 65
- troubleshooting
 - audio 129
 - drives, PC Cards, and peripheral devices 123
 - general 115
 - LCD screen 120
 - Memory Stick media 131
 - modem 128
 - mouse and pointing device 121
 - software 126

TV

connecting 65

U

USB port 48

using

Jog Dial control 29

Memory Stick 33

PC Cards 37

pointing device 26

V

VAIO Action Setup 28

VAIO® Action Setup 29

video camera 61

VisualFlow 35

volume

adjusting 18

W

window design of Sony software 88

Windows

Explorer 14

Find window 15

help 14

key 14

key combinations 14

taskbar 118

Wireless LAN 74