

Contents

Welcome.....7

Using Your VAIO Notebook.....9

- Using the Keyboard.....10
 - Combinations and functions with the Windows key12
 - Indicators13
 - Indicator lights13
 - Combinations and functions with the Fn key14
- Using the Touchpad16
- Using the Floppy Disk Drive18
- Using the Optical Disc Drive21
 - To insert a disc21
 - To eject a disc22
 - To play a DVD.....23
 - To play an audio CD.....24
 - Notes on CD and DVD discs24
 - To write data to a CD-RW or CD-R disc.....25
- Using PC Cards26
 - To insert a PC Card.....26
 - To remove a PC Card.....28
- Using a Second Battery Pack29
 - To insert a second battery pack.....29
 - To charge the second battery pack.....30
 - To view remaining battery power30
 - To remove the second battery pack31

Using the Weight Saver	32
To attach the weight saver	32
To remove the weight saver	33
Using Power Saving Modes.....	34
Normal mode.....	34
Standby mode.....	34
Hibernate mode.....	34
Connecting a Phone Line	36
Connecting to a LAN	37
Setting up your Ethernet connection.....	37

Connecting Peripheral Devices 39

Connecting a Port Replicator	40
To attach your notebook to the port replicator.....	41
To remove your notebook from the port replicator.....	44
Connecting a PS/2 External Mouse or Keyboard	46
To connect an external mouse or keyboard	46
Connecting an AV Device	47
Connecting a Parallel Port Printer	48
To connect a printer	48
Connecting a USB Printer.....	49
To connect a USB printer.....	49
Connecting an External Display	50
To connect a computer display	50
To connect a multimedia computer display	51
To connect a projector.....	51
To select a display.....	51
Connecting a USB Device	53
To connect a USB device.....	53

Connecting an i.LINK Device.....	54
To connect a digital video camera recorder.....	54
Connecting with another VAIO computer	56
Connecting External Speakers	57
Before connecting external speakers	57
To connect external speakers.....	57
Connecting an External Microphone.....	58
To connect an external microphone.....	58
Expanding Your Notebook Capabilities	59
Personal Digital Assistant.....	59
Wireless LAN Access Point	59
Wireless LAN PC Card.....	60

Customizing Your VAIO Notebook61

Selecting the Display Mode	62
Changing the window design of Sony software.....	65

Adding Memory67

Precautions and Procedures.....	68
Typical expansion memory configuration.....	69
Models with 128 MB memory.....	69
Models with 256 MB memory.....	69
Removing a memory module	70
Installing a memory module.....	72
Viewing the amount of memory.....	73

About the Software on Your Notebook ...75

Software Overview.....	76
Application, Driver, and System Recovery CDs.....	81

Using Your Recovery CDs	82
To use the Application Recovery CD(s)	82
To use the Driver Recovery CD(s)	83
To use the System Recovery CD(s)	87

Troubleshooting.....89

Troubleshooting Your Notebook	89
My notebook does not start.	89
My notebook starts but a BIOS error appears.	90
My notebook starts, but the message “Operating system not found” appears and Windows does not start.	90
My notebook stops responding or does not shut down.	91
The power management setting is not responding.	92
Why does the System Properties dialog box display a slower CPU speed than advertised?.....	92
Troubleshooting the LCD Screen	93
My LCD screen is blank.	93
My LCD screen continues to show the previous screen. ..	93
The image on my connected external display is not centered or sized properly.....	93
I want to change the video resolution of my display.	93
I cannot switch the LCD display to TV, and vice versa. ..	93
Troubleshooting the Mouse and Touchpad	94
My mouse does not work.	94
My touchpad does not work properly.	94
The pointer does not move while using the Touchpad or Mouse.....	94
Troubleshooting Drives, PC Cards and Peripheral Devices	96
My floppy disk drive cannot write to a floppy disk.	96
My optical disc drive is not playing my CD or DVD proper-	

ly.	96
My optical drive tray does not open.	97
I cannot use Digital Video (DV) devices. The message “DV equipment seems to be disconnected or turned off” appears.	97
My PC Card is not working.	97
Troubleshooting Software	98
My software program stops responding or crashes.	98
When I click an application icon, the message “You must insert the application CD into your optical drive” appears and the software does not start.	98
I cannot use the DVgate™ software.	98
My computer’s start-up time seems longer after I have installed AOL. What can I do?	98
Troubleshooting the Modem	99
My modem does not work.	99
My modem connection is slow.	99
Troubleshooting Audio	100
My speakers make no sound.	100
My microphone does not work.	100
Troubleshooting the Printer	101
I cannot print.	101
Troubleshooting i.LINK devices	102
I cannot establish a connection between two VAIO computers when using an i.LINK cable.....	102

Getting Help..... 103

Support Options.....	104
Software Support Information.....	106
Sony Service Center.....	107

Index..... 109

Welcome

Congratulations on your purchase of this Sony VAIO computer, and welcome to the VAIO User Guide.

This User Guide provides detailed information on all aspects of using your new VAIO computer, from keyboard functions to preinstalled software applications.

In the left navigation window, click the topics you want to learn more about, and that information will be displayed in this main window.

Change text in this variable definition to document title.

Using Your VAIO Notebook

This section describes the following aspects of your new computer:

- Using the Keyboard
- Using the Touchpad
- Using the Floppy Disk Drive
- Using the Optical Disc Drive
- Using PC Cards
- Using a Second Battery Pack
- Using the Weight Saver
- Using Power Saving Modes
- Connecting a Phone Line
- Connecting to a LAN

Change text in this variable definition to document title.



Using the Keyboard

Your notebook keyboard is very similar to that of a typewriter, but the keyboard has additional keys that perform specific computer-related tasks.

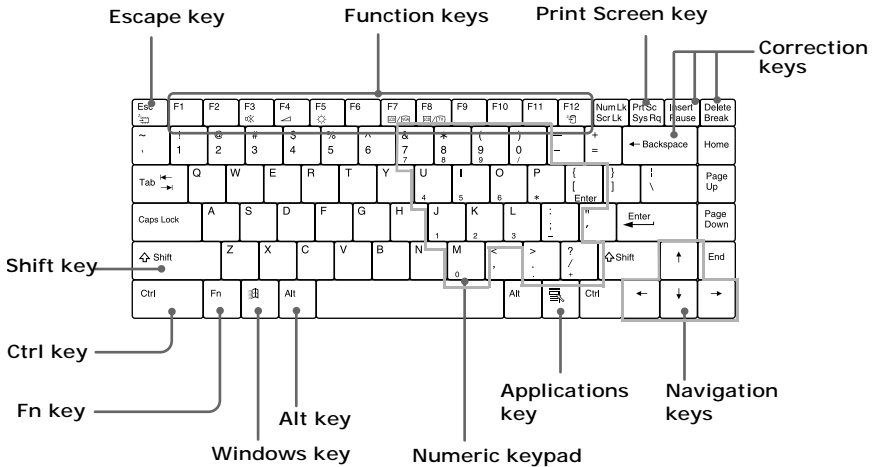
Keyboard













<i>Key</i>	<i>Description</i>
Numeric keypad	Contains the keys found on a typical calculator. Use the numeric keypad area to type numbers or to perform mathematical calculations such as addition and subtraction. Note that you must press the Num Lock key to activate the numeric keypad. (When you do so, the Num Lock light will be on.)
Navigation keys	Several keys are devoted to moving the cursor on the screen.
Correction keys	The Insert, Back Space, and Delete keys enable you to make corrections in your documents.





<i>Key</i>	<i>Description</i>
Function keys	The twelve function keys along the top of the keyboard are used to perform designated tasks. For example, in many applications, F1 is the Help key. The task associated with each function key may vary from one application to the next.
Escape key	The Esc (Escape) key is used to cancel commands.
Print Screen key	The Print Screen key takes an electronic snapshot of the screen and places it in the Windows Clipboard. You can then paste the screen shot into a document and print it.
Operator keys (Shift, Ctrl, Alt keys)	Several keys are always used with at least one other key: Ctrl, Alt, and Shift. When held down with another key, the Ctrl (Control) and Alt (Alternate) keys offer another way to give commands. For example, in many applications, instead of choosing the Save command from a menu, you can hold down Ctrl and press S (referred to as Ctrl+S). The Shift key operates the same way as on a typewriter; it is used to produce capital letters or special symbols such as @ and \$.
Windows key 	The key with the Windows logo displays the Windows Start menu; it is the equivalent of clicking the Start button on the taskbar. See “Combinations and functions with the Windows key” for more information.
Fn key	The Fn key is used in combination with other keys to issue commands. See “Combinations and functions with the Fn key” for more information.
Applications key 	The Applications key displays a shortcut menu of context-sensitive choices. Pressing this key is the equivalent of clicking the right mouse button.

Change text in this variable definition to document title.

Combinations and functions with the Windows key

Combination	Function
 + F1	Displays VAIO® Help and Support Center.
 + Tab	Switches the selected button on the taskbar.
 + D	Displays the desktop.
 + E	Displays Windows Explorer.
 + F	Displays the Windows Find: All Files window to find a file or folder. This is the equivalent of selecting Find and then Files or Folders from the Start menu.
 + Ctrl + F	Displays the Windows Find: Computer window where you can locate other computers. This is the equivalent of selecting Find and then Computer from the Start menu.
 + M	Minimizes all displayed windows.
Shift +  + M	Returns all minimized windows to their previous size.
 + R	Displays the Run window. This is the equivalent of selecting Run from the Start menu.
Fn +  + Insert	Displays the Properties window. This is the equivalent of double-clicking the System icon in the Control Panel.

Indicators

<i>Indicator</i>	<i>Function</i>
Power 	Light is green when the power to the notebook is turned on, flashes amber in Standby mode, and turns off when the notebook is in Hibernate mode or powered off.
Battery 1 1 	Indicates the status of the battery inserted in the battery bay on the right side of the notebook.
Battery 2  2	Indicates the status of the battery inserted in the multipurpose drive bay on the left side of the notebook.
Hard disk 	This indicator will light when data is being read from or written to the hard disk. Do not enter Standby mode or turn off the notebook when this indicator is on.

Indicator lights

<i>Light</i>	<i>On</i>	<i>Off</i>
Num Lock	The number keys in the numeric keypad are active.	The alphanumeric character keys in the keypad area are active.
Caps Lock	The letters appear in uppercase as you type. The Shift key lowers the case of typed letters when Caps Lock is on.	Letters appear in lower case as you type (unless you hold down the Shift key).
Scroll Lock	The screen scrolls differently. (Exactly how it scrolls depends on the specific application. It has no effect in many applications.)	Information moves across the display normally.

Change text in this variable definition to document title.

Combinations and functions with the Fn key





If you switch user identities during a computing session, the Fn+F7 and Fn+F8 key functionality (if available on your computer) will be interrupted. To switch to an external display or monitor, see "Selecting the Display Mode" for more information.

Combinations/ Feature	Function
----------------------------------	-----------------

Fn+  (F3) Mute On/Off	Toggles the built-in speaker off and on.
---	--

Fn+  (F4) Speaker volume	Adjusts the built-in speaker volume. To increase volume, press Fn+F4.
--	--

Fn+Shift+  (F4) Speaker volume	Adjusts the built-in speaker volume. To decrease volume, press Fn+Shift+F4.
--	--

Fn+  (F5) Brightness control	Adjusts the brightness of the LCD. To increase light intensity, press Fn+F5.
--	---

Fn+Shift+  (F5) Brightness control	Adjusts the brightness of the LCD. To decrease light intensity, press Fn+Shift+F5.
--	---

**Combinations/
Feature**
Function

Fn+ **LCD** / **VGA**
(F7)
Switch to the
external
monitor/LCD

Toggles through the LCD, external display (connected to the
□ Monitor connector) and both LCD and external display.

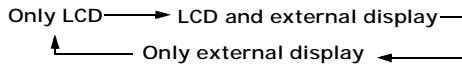

Connect the cable before you turn on the notebook, otherwise
Fn + F7 will not work.

Fn+ **LCD** only/
TV (F8)
Control AV out

Toggles between LCD-only and dual LCD/TV display
modes.

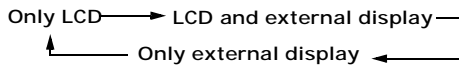

Connect the cable before you turn on the notebook, otherwise
Fn + F8 will not work.

Fn + Esc
System Standby

Puts the system into Standby mode, a power management
state. To return the system to the active state, press any key.



Some functions are not available until Windows launches.

Using the Touchpad

The keyboard contains a cursor-pointing device called a touchpad. You can point to, select, drag, and scroll objects on the screen using the built-in touchpad.

Touchpad

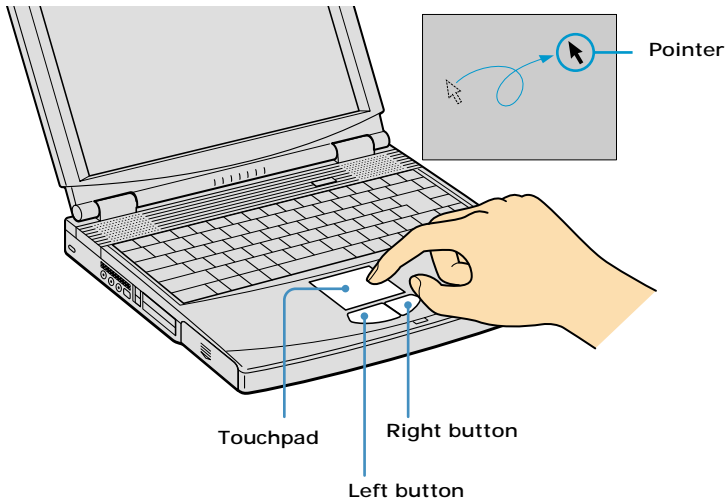

<i>Action</i>	<i>Description</i>
Point	Slide one finger on the touchpad to place the pointer on an item or object.
Click	Press the left button once.
Double-click	Press the left button twice.

<i>Action</i>	<i>Description</i>
Right-click	Press the right button once. In many applications, this action displays a shortcut menu of context-sensitive choices.
Drag	Slide one finger while pressing the left button.
Scroll	Move your finger along the right edge of the touchpad to scroll vertically. Move your finger along the bottom to scroll horizontally. (The scroll function is available only with applications that support a touchpad scroll feature.)

See Mouse Properties for information on touchpad features, such as clicking both buttons simultaneously, adjusting touchpad speed, and Easy Launcher functions. To access Mouse Properties, open the Start menu, point to Control Panel, Printers and other Hardware, and then click the Mouse icon in the Control Panel.

Using the Floppy Disk Drive

Your computer comes with a floppy disk drive in the multipurpose bay.

To insert a disk

- 1** Hold the disk with the label side facing up.
- 2** Gently insert the disk into the drive until it clicks into place.

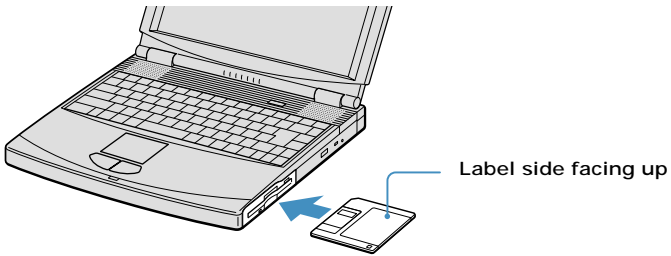

To remove a disk

- 1 Wait until the LED indicator light turns off and then press the Eject button to remove the disk.

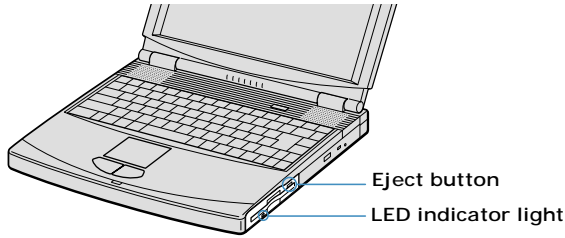

Do not push the eject button when the LED indicator is turned on. Otherwise, data may be lost.

To remove the floppy disk drive

- 1 Turn off the notebook.
- 2 There is a RELEASE lever on the bottom of the computer. Slide this lever in the direction of the arrow.

Multipurpose bay release lever

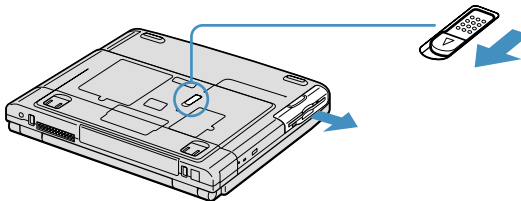

- 3 Slide the drive out of the multipurpose bay.
- 4 Insert the weight saver. See “Using the Weight Saver” for details.

Change text in this variable definition to document title.

To reinsert the floppy disk drive

- 1 Turn off the notebook.
- 2 If another device is in the multipurpose bay, remove the device. See “To remove the second battery pack” for details.
- 3 Insert the floppy disk drive, with the VAIO label facing up, into the multipurpose bay until the RELEASE lever locks into place.

Inserting the floppy disk drive

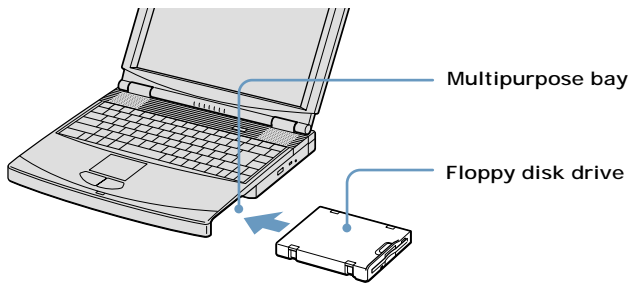

Using the Optical Disc Drive

Your notebook comes with an optical disc drive. Depending on the system you purchased, your optical disc drive is either a CD-RW/DVD Combo Drive or a DVD-ROM drive.

To insert a disc

- 1 Turn on the notebook.



When the notebook is in Standby or Hibernate mode, you cannot insert a disc. See "Using Power Saving Modes" for more information on Standby and Hibernate modes.

- 2 Press the Eject button to open the optical drive.

The tray slides out.

Ejecting the tray

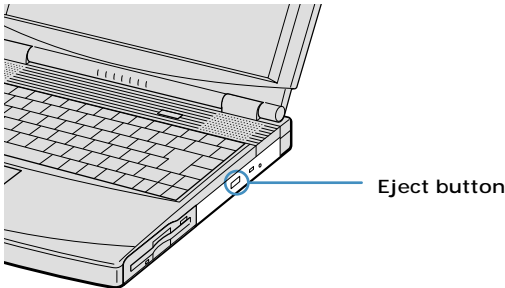

Avoid using adhesive labels to identify your discs. Adhesive labels may come off while the disc is in use in your optical drive, and may cause damage to the unit.

- 3 Place an optical disc on the tray with the label side facing up. For DVDs that can be played on both sides, the side of the disc facing up is the side that plays.

Change text in this variable definition to document title.

- 4 Press the disc onto the hub until the disc clicks securely into place.

Inserting an optical disc

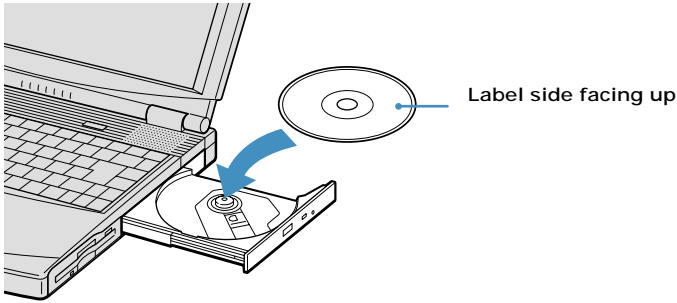

- 5 Close the tray by pushing it gently.

To eject a disc

When you finish using a disc, wait until the LED indicator turns off, and then press the Eject button to remove the disc.

When the notebook is in a power saving mode, you cannot remove an optical disc. See “Using Power Saving Modes” for more information about power saving modes.

If the optical disc does not slide out when you press the Eject button, turn off the notebook and insert a thin, pointed object (such as a paper clip) into the manual eject hole.



Make sure to seat the disc firmly over the hub fingers. If you do not seat the disc firmly, you could damage your optical drive and you may not be able to open the tray.

Manual eject hole

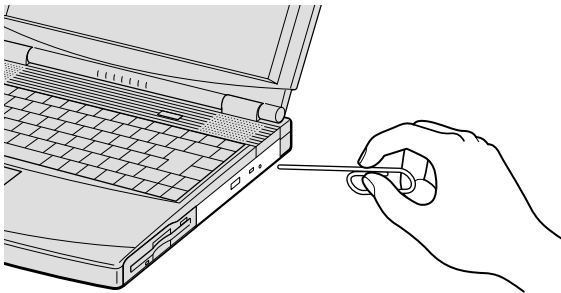

To play a DVD

To play a DVD, you may use the optical disc drive and the preinstalled WinDVD® application. For more information on WinDVD, see the Help menu WinDVD application.



Before you use the optical disc drive to play a DVD, quit any open applications.

Your optical drive can read most DVD-R media. When you are ready to play a DVD, read the suggestions below to maximize your video viewing experience.

- ❑ If you connect your notebook to a TV display, you may need to adjust the display resolution. Read the suggestions below to set the display resolution to the proper dimensions. Also see “Selecting the Display Mode” for more information.

Change text in this variable definition to document title.

- ❑ If the notebook is set to the default display setting, part of the video screen will not appear. To view the entire screen, adjust the display resolution to 640 x 480.
- ❑ You cannot use the Fn + F8 function to switch between LCD and TV once a DVD is inserted into the optical drive.
- ❑ Change the settings to disable the screen saver and the virus checker.



Some discs recorded at 20 or 24 bits may produce noise while playing. If you have audio devices connected, this may cause damage to your hearing and the speakers. Reduce the volume before playing a DVD.

Do not switch between LCD and the external display while the DVD is playing. This may cause a malfunction, and you may need to restart the DVD software.

Do not switch the power saving modes while you are playing the DVD.

Do not use memory-resident utility software to speed up disc access. This may cause the notebook to malfunction.

To play an audio CD

To play an audio CD, make sure the audio function is turned on. To do this, complete the following procedure.

- 1 Open the Start menu, point to Control Panel, and then click System. The System Properties window appears.
- 2 Select the Hardware tab and then click Device Manager in the Device Manager box. A window appears, listing your notebook hardware devices.
- 3 Double-click DVD/CD-ROM drives. From the drop-down list, double-click the drive name. A properties window appears.
- 4 Select the “Enable digital CD audio for this CD-ROM device” check box if it is not already selected and then click OK.

Notes on CD and DVD discs

- ❑ Do not drop or bend the disc.
- ❑ Do not touch the surface of the disc. Fingerprints and dust on the surface of a disc may cause reading errors. Proper care of the disc is essential to maintain

its reliability. Do not use solvents such as benzene, thinner, commercially available cleaners or anti-static spray, as they may cause damage to the disc.

- ❑ For normal cleaning, hold the disc by its edge and use a soft cloth to wipe the surface from the center out.
- ❑ If the disc is badly soiled, moisten a soft cloth with water, wring it out well, and use it to wipe the surface of the disc from the center out. Wipe off any remaining moisture with a dry, soft cloth.

To write data to a CD-RW or CD-R disc *

You can use Sony SonicStage and Microsoft® Windows® XP to write data to a CD-R or CD-RW disc. To create a CD-R disc that is readable in a CD-ROM drive, make sure that you finish the writing process before ejecting the disc. For more information, see the instructions included with Windows® XP.

Notes on writing data to a CD-RW or CD-R disc

- ❑ For optimal writing speed, deactivate the screen saver and exit anti-virus software before writing data to a disc.
- ❑ For best results, use CD-Rs that are compatible with 8x speed.
- ❑ Your notebook does not support 1x writing speed.
- ❑ If your notebook computer has preinstalled Microsoft® Office applications, such as Excel, Word, and Outlook, turn off the FindFast application.

* For notebook models equipped with a CD-RW/DVD Combo Drive.

Using PC Cards



Do not strike or shake the notebook while writing data to a disc.

Always use the AC adapter as the power source for your notebook if you are writing data to a CD-RW or CD-R disc. Using battery power may result in data transfer failure.

Your notebook includes two PC Card slots. PC Cards enable you to connect portable external devices such as another hard disk drive, or a PC Network Interface Card (NIC) to connect to a network.



The PC Card slots can accommodate two Type I/II PC Cards, or one Type III PC Card. These slots are compatible with CardBus. Use the lower slot for Type III PC Cards. You do not need to shut down your notebook before inserting or removing a PC Card.

To insert a PC Card

- 1 Push the Release button once. The Release button pops out.

PC Card release button

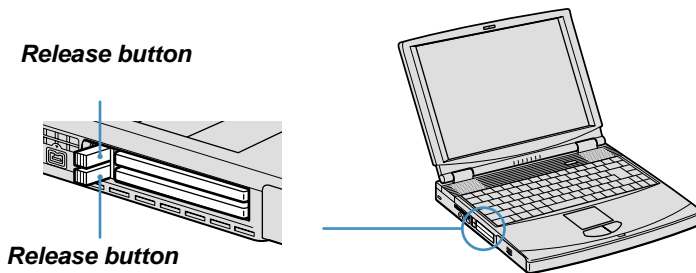

- 2 Push the Release button a second time. The PC Card slot protector pops out. When you use a Type III PC card, you need to remove both the top and bottom PC Card slot protectors.

PC Card slot protector

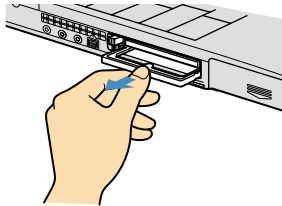

- 3 Insert the the PC Card gently into the slot. Make sure the front label of the PC Card is facing up. The PC Card is automatically detected by your system. The  Unplug or Eject Hardware icon appears in the taskbar.

Inserting a PC Card

Insert with the arrow facing toward the slot

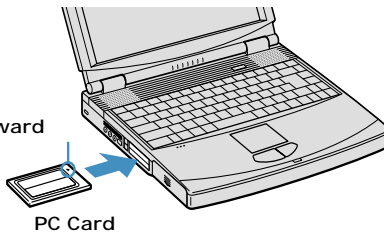

Do not force a PC Card into the slot as this may damage the connector pins.

Do not carry your notebook while touching the head of a PC Card (such as a wireless LAN card), as pressure or shock may damage the connector pins.

To remove a PC Card

The following procedure describes how to remove the PC Card while the notebook is on. If you want to remove the PC Card while the notebook is off, perform steps 4, 6, and 7 below.

- 1 Double-click  in the taskbar. The “Safely remove ... PC Card” dialog box appears.
- 2 Click the PC Card’s name or drive. The message, “Safe to Remove Hardware” appears.
- 3 Click to close the message.
- 4 Push the Release button. The Release button pops out.
- 5 Click OK again and then click Close.
- 6 Gently grasp the PC Card and pull it out of the slot.
- 7 Insert the PC Card slot protector into the empty slot.

Notes on using PC Cards

- ❑ For some PC Cards, if you alternate between normal power operation and the Standby or Hibernate power management modes while the card is inserted, you may find that a device connected to your system is not recognized. Restart your system to correct the problem.
- ❑ Some PC Cards may require that you disable idle devices when using the PC Card.
- ❑ Be sure to use the most recent software driver provided by the PC Card manufacturer.
- ❑ If an exclamation mark (!) appears on the Device Manager tab in the System Properties dialog box, remove the software driver and then reinstall it.
- ❑ You may not be able to use some PC Cards or some functions of the PC Card with this notebook. If you have difficulty inserting a card, check that you are orienting the card correctly. See the manual that came with your PC Card for more information on its use.

Using a Second Battery Pack

You can purchase a second rechargeable battery pack. With two battery packs, you can extend the time that you use your notebook with battery power. When using two battery packs, the battery pack you insert first charges first. The battery pack you insert second begins charging when the first battery pack is 85 percent full. You can monitor which battery pack is charging by observing the battery indicators.

To insert a second battery pack

- 1 If another device is in the multipurpose bay, remove that device.
- 2 Insert the battery pack into the multipurpose bay.

If the battery is being used, the battery 2 indicator turns on.

Second battery in multipurpose bay

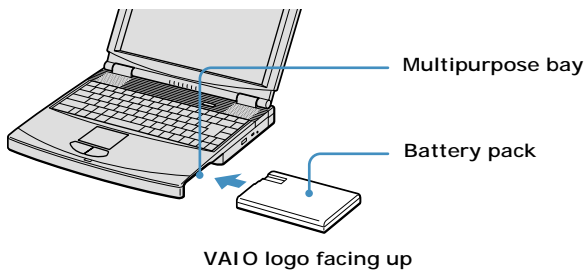

- 3 Attach the weight saver to the notebook to stabilize the battery pack. See “Using the Weight Saver” for more information.

To charge the second battery pack

Using weight saver for second battery cover

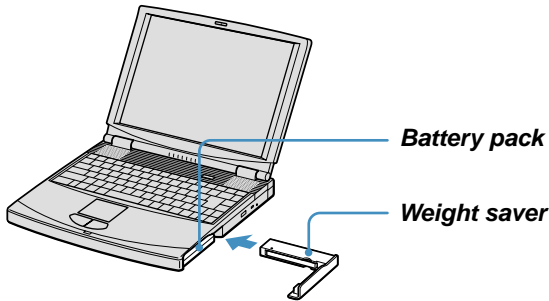

Keep the battery pack in the notebook while it is connected to AC power. The battery indicator flashes while the battery is charging. See also “To charge the battery pack” in the printed Quick Start for more information.

Charging the second battery

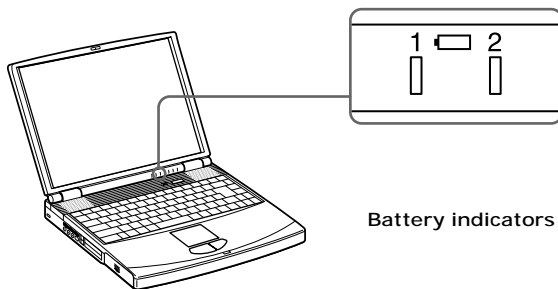

To view remaining battery power

To view remaining battery power, perform the following steps.

- 1 Click Start in the Windows taskbar, Control Panel, Performance and Maintenance, and then click Power Options. The Power Options Properties dialog box appears.
- 2 Click the Power Meter tab. The current power source and total battery power remaining is shown.

To remove the second battery pack

If you attach two battery packs, you can remove either of them without shutting down the notebook. When removing one battery pack, make sure that the other battery pack's indicator is on. If the indicator of the battery pack you are removing is on, right-click the battery icon on the taskbar and click the "Switch discharge battery" option.

- 1 There is a Release lever on the bottom of the weight saver. To remove the battery pack, slide this lever in the direction of arrow 1, and then slide the RELEASE lever on the bottom of the notebook in the direction of arrow 2.

Multipurpose bay Release levers

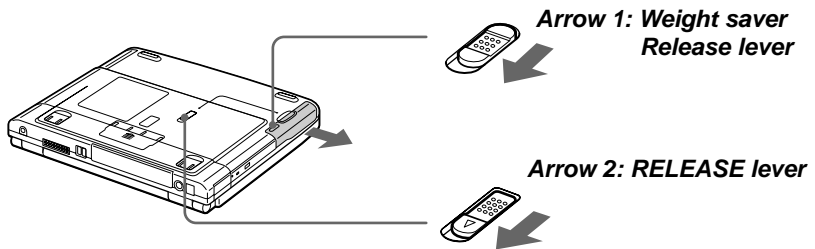

- 2 Remove the weight saver, and then pull out the battery pack.
- 3 Reinsert the weight saver. See "Using the Weight Saver" for more information.

Using the Weight Saver

The weight saver protects the multipurpose bay when it is empty, and secures the secondary battery when it is installed in the multipurpose bay.

To attach the weight saver

- 1 If another device, such as a battery pack, is in the multipurpose bay, remove that device. See “To remove the second battery pack” for more information.
- 2 Fold out the hinged arm of the weight saver and then push on the hinged arm to lock it into place. Slide the weight saver in the direction of the arrow until it clicks into place.

Inserting the weight saver

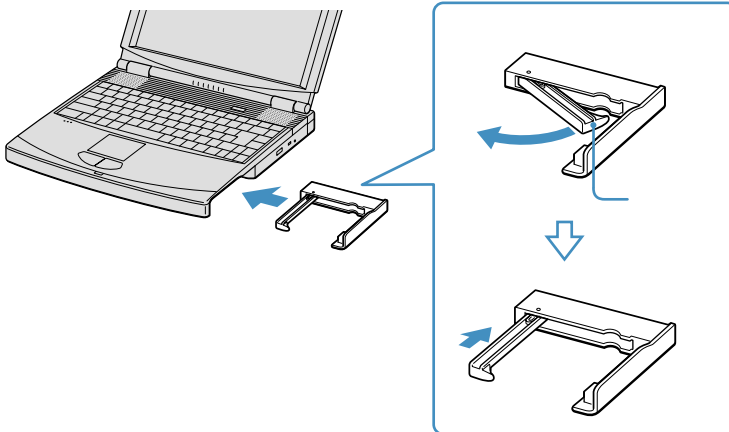

- 3 Manually lock the weight saver's Release lever.

To remove the weight saver

- 1 To remove the weight saver, first slide the multipurpose bay Release lever in the direction of the arrow.

Multipurpose bay Release lever

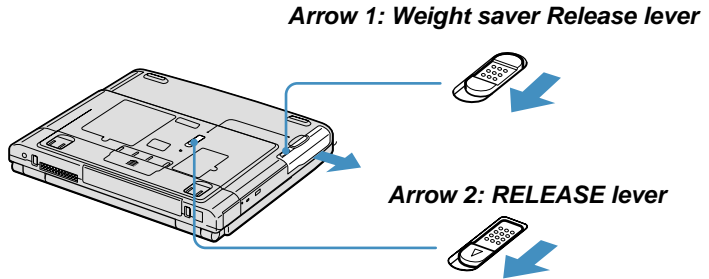

- 2 Remove the weight saver.

Using Power Saving Modes

When you use a battery as the source of power for your notebook, you can take advantage of power management settings to conserve battery life. In addition to the normal operating mode, which allows you to turn off specific devices, your notebook has two distinct power saving modes: Standby and Hibernate. When using battery power, be aware that the notebook automatically enters Hibernate mode when the remaining battery charge drops below 5 percent, regardless of the power management setting you select.



If the battery level falls below 10 percent, you should either attach the AC adapter to recharge the battery or shut down your notebook and insert a fully charged battery.

Normal mode

Normal mode is the normal state of your notebook when it is in use. The power indicator displays green when your notebook is in this mode. To save power, you can turn off a specific device such as the LCD or the hard disk drive.

Standby mode

In Standby Mode the notebook saves the current state of the system in RAM and switches off power to the CPU. The amber power indicator flashes in this mode.

To activate Standby mode

To activate Standby mode, press the key combination Fn+Esc.

To return to normal mode

Press any key to return to normal mode.

Hibernate mode

In the Hibernate mode, the state of the system is saved on the hard disk drive and power is turned off. The power indicator is off in this mode.

To activate Hibernate mode

To activate Hibernate mode, press the power button and release it immediately, or do the following:

- 1 Click Start in the Windows taskbar, and select Turn Off Computer.
- 2 Hold down the Shift key, and click Hibernate. The computer goes into Hibernate mode.



The "Save to Disk Manager" screen appears, and then the notebook enters Hibernate mode.

Do not move the notebook until its power indicator turns off.

To return to normal mode

To return to normal mode, turn on the notebook by pressing the power button. The notebook returns to its previous state.



When returning from Hibernate mode, the system status stored on the hard disk is erased and the notebook starts normally if you press the power button and hold for more than four seconds.

- Time required to return to normal mode
Standby requires less time than Hibernate to return to normal mode.
- Power consumption
Standby uses more power than Hibernate.

Connecting a Phone Line

You need to connect a phone line to take advantage of online services and the Internet.

 In order to register your Sony VAIO notebook, register your software online, and use Sony Customer Support, you must connect to a phone line.

- 1 Plug one end of the phone cable into the modem jack on the notebook.

Connecting phone cable

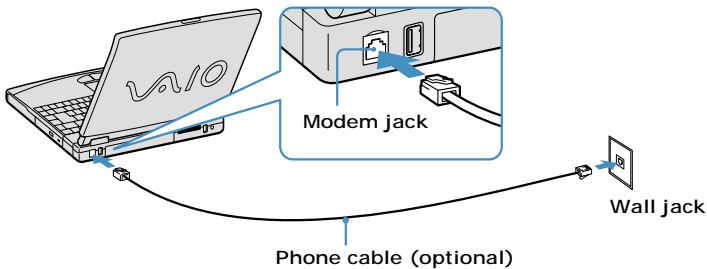

- 2 Plug the other end of the phone cable into the wall jack.

 Your notebook does not work with party lines, cannot be connected to a coin-operated telephone, and may not work with multiple phone lines or a private branch exchange (PBX). Some of these connections may result in excess electrical current and could cause a malfunction in the internal modem.

If you connect a phone line coming through a splitter, the modem or connected device may not work properly.

Connecting to a LAN

You can connect your notebook to 10Base-T and 100Base-TX-type Local Area Networks (LANs). For the detailed settings and devices needed to connect to the network, ask your network administrator.

Connecting to LAN

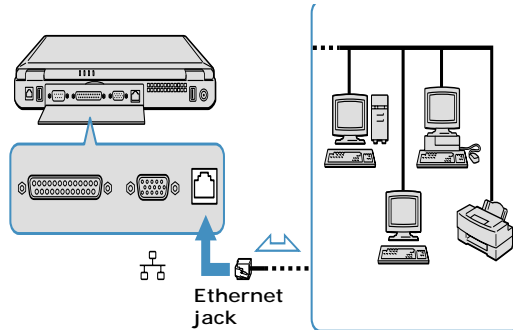

Warning: Only connect 10Base-T and 100Base-TX cables to the  Ethernet jack. Do not connect any other type of network cable or phone cable. Connecting cables other than those listed above may result in an electric current overload and could cause a malfunction, excessive heat, or fire in the port. To connect the unit to the network, contact your network administrator.

Setting up your Ethernet connection

To connect to the network

- 1 Click Start, select My Computer, and then click My Network Places under the the “Other Places” heading.
- 2 Click “Add a network place” under the Network Tasks heading, or click “Set up a home or small office network,” depending on your configuration.
- 3 Depending on your choice, either the “Add Network Place Wizard” or the “Network Setup Wizard” is displayed.
- 4 Follow the step-by-step instructions that appear on the screen.

Change text in this variable definition to document title.

Connecting Peripheral Devices

You can add functionality to your notebook by connecting a variety of peripherals, as discussed in the following sections:





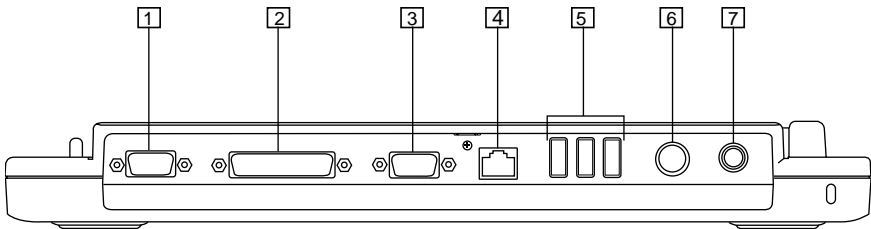

- Connecting a Port Replicator
- Connecting a PS/2 External Mouse or Keyboard
- Connecting an AV Device
- Connecting a Parallel Port Printer
- Connecting a USB Printer
- Connecting an External Display
- Connecting a USB Device
- Connecting an i.LINK Device
- Connecting with another VAIO computer
- Connecting External Speakers
- Connecting an External Microphone
- Expanding Your Notebook Capabilities

Connecting a Port Replicator

Your notebook supports the use of a port replicator such as the Sony PCGA-PRFX1 model (optional). Attaching a port replicator enables you to connect additional peripherals to your notebook.

Port replicator



1	 Serial port	5	 USB ports
2	 Printer port	6	 Mouse/Keyboard (PS/2) port
3	 Monitor port	7	 DC In port
4	 Network port (Ethernet 10Base-T/100Base-TX)		



The port replicator can be powered only with an AC power adapter. Do not remove the AC adapter from the port replicator or the AC outlet while using the port replicator; this may cause data damage or hardware malfunctions.

To attach your notebook to the port replicator

To supply power to your notebook while it is connected to the port replicator, connect the AC adapter directly to the port replicator.



When attaching your notebook to the port replicator, do not attempt to insert or remove the battery pack. Lifting and turning the notebook with an attached port replicator could cause a temporary loss of power, and may result in data loss.

- 1 Turn off the notebook and disconnect all peripheral devices.
- 2 On the bottom of the notebook, slide the port replicator cover open.

Port replicator connector

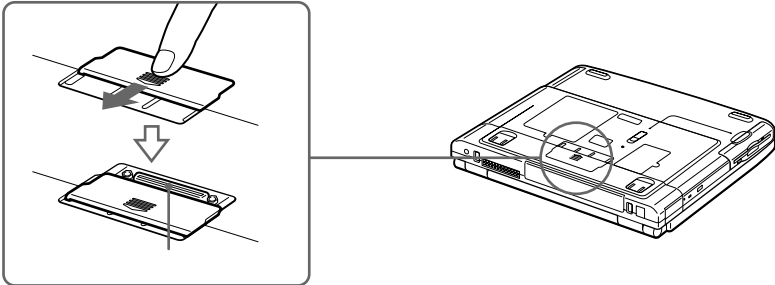

- 3 If necessary, close the tilt stands before attaching the notebook to the port replicator.

Change text in this variable definition to document title.

- 4 Attach the bottom of the notebook to the port replicator connector until it clicks into place.

Attaching notebook to port replicator

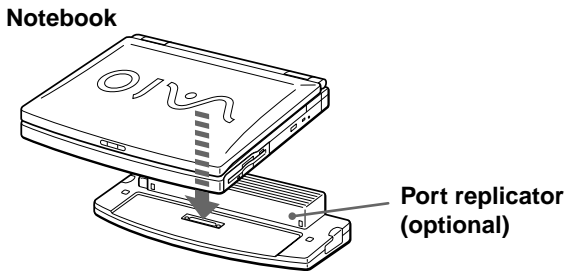

- 5 Plug the cable attached to the AC adapter into the DC IN jack on the port replicator.

- 6 Plug the power cord into the AC adapter and an AC outlet. The power indicator turns green.

Connecting AC adapter to port replicator

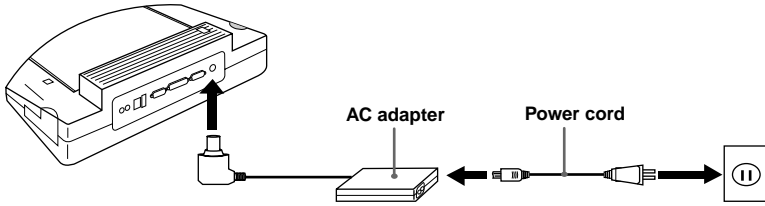

 Use the AC adapter that comes with your notebook or the optional Sony adapter.

Power indicator

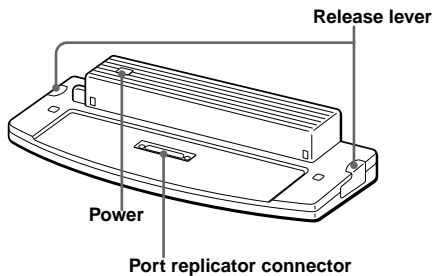

- 7 Turn on the notebook.

To remove your notebook from the port replicator

- 1 Turn off your notebook and the connected peripherals.
- 2 Pull the levers on each side of the port replicator to release the notebook from the port replicator.

Releasing notebook from port replicator

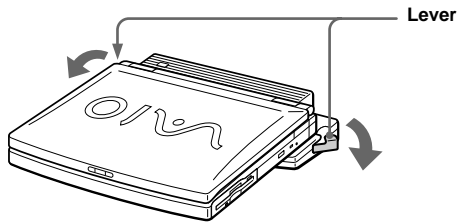

- 3 Lift the notebook away from the port replicator.

Removing notebook from port replicator

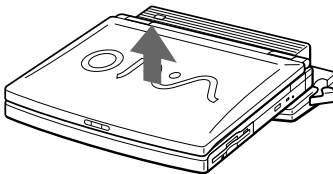

- 4 Close the port replicator connector cover on the bottom of your notebook.



Close the port replicator connector cover after removing your notebook from the port replicator. If the cover is left open, dirt may get inside and damage the notebook.



Connecting a PS/2 External Mouse or Keyboard

You can connect an external mouse or keyboard to the optional port replicator using a similar type PS/2® plug or adapter.

 Before you connect or disconnect the mouse or keyboard, turn off the notebook.

You can only connect one external device at a time. Therefore, it is impossible to connect both a PS/2 mouse and PS/2 keyboard simultaneously.

To connect an external mouse or keyboard

- ❑ Locate the mouse and keyboard port on the port replicator identified by the  /  symbols.
- ❑ Plug the mouse or the keyboard cable into this port with the arrow facing upward.

Connecting external mouse or keyboard

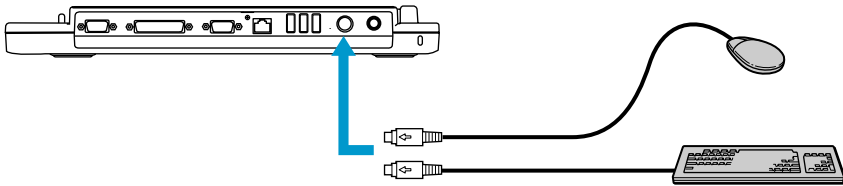

 See the manual that came with your mouse or keyboard for more information on its installation and use.

Connecting an AV Device

You can connect an audio-video (AV) device, such as a TV, to your notebook.

Connecting a TV to the Notebook

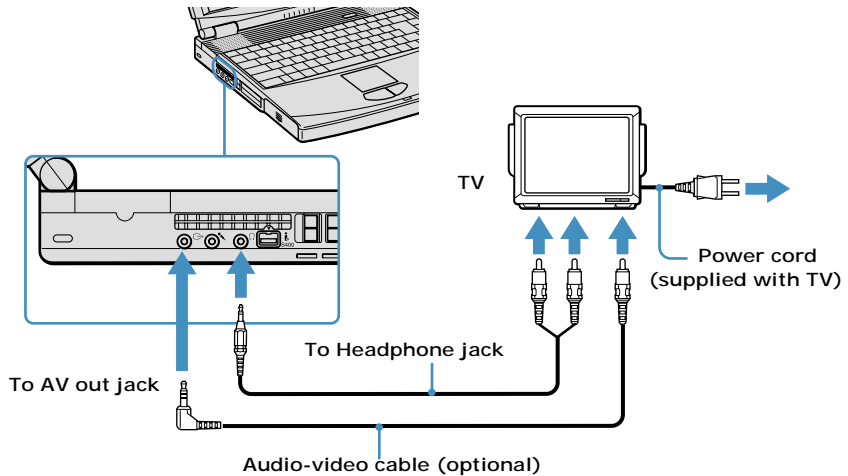

See the manual that came with your peripheral device for more information on its installation and use.

If you insert a DVD in your optical drive to watch a video on your TV, the Fn+F8 key combination might not activate the function to toggle between your LCD and TV. Do the following steps:

- 1 Connect the TV to the notebook.
- 2 Restart the notebook and wait until it finishes.
- 3 Toggle between your LCD and your TV with the Fn+F8 key combination. Your image is now displayed on both LCD and TV. Re-insert your DVD to launch your DVD software.



A part of the image cannot be displayed on your TV display if the resolution of your notebook is more than 1024 x 768 dots.

Connecting a Parallel Port Printer

You can connect a Windows XP operating system-compatible printer to your notebook to print documents.

To connect a printer

- ❑ Locate the Printer port identified by the  symbol. Plug the printer cable (supplied with the printer) into this port on the notebook.

Printer connector

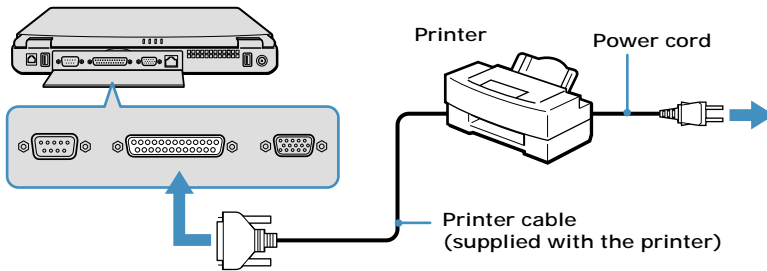

 See the manual that came with your printer for more information on its installation and use.

If your printer stops functioning after resuming from a power saving mode, see "Troubleshooting the Printer" for more information.

Connecting a USB Printer

You can connect a Windows XP operating system-compatible USB printer to either of your notebook's two USB ports to print documents.

 To use a printer, first install the driver software that came with your printer.

To connect a USB printer

Plug the optional USB printer cable into either of the two USB ports on your notebook and the USB port on your printer.

Connecting a USB Printer

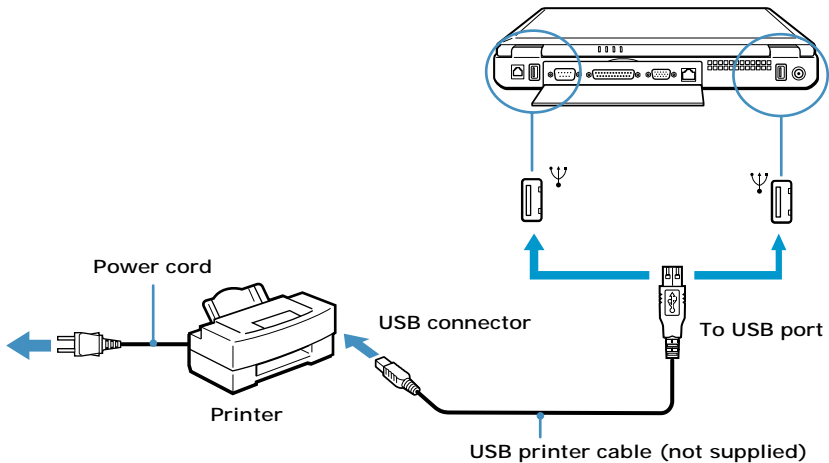

 See the manual that came with your printer for more information on its installation and use.

Connecting an External Display

You can connect an external display to your notebook. For example, you can use the notebook with any of the following:

- ❑ Computer display (monitor)
- ❑ Multimedia computer display
- ❑ Projector

 Connect the external display before you turn on the notebook.

To connect a computer display

- 1 Locate the Monitor jack identified by the  symbol on the back of the notebook.
- 2 Plug the display cable (optional) into this port.
- 3 If necessary, plug one end of the display power cord into the display, and the other end into an AC outlet.

Connecting an external computer display

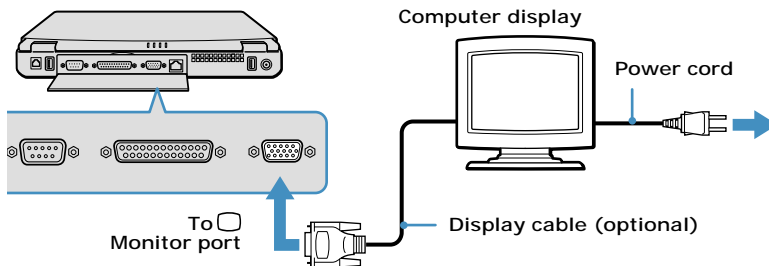

 See the manual that came with your computer display for more information on its installation and use.

To connect a multimedia computer display

You can connect your notebook to a multimedia computer display that includes built-in speakers and a microphone.

 See the manual that came with your multimedia computer display for more information on its installation and use.

To connect a projector

You can use a projector, such as the Sony LCD Projector, as an external display.

Connecting a projector

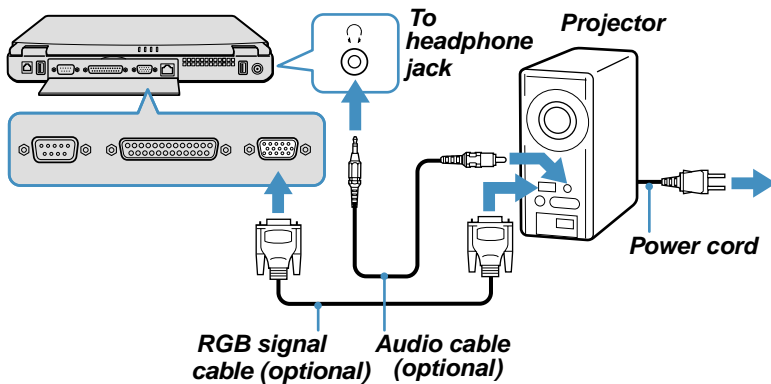

 See the manual that came with your projector for more information on its installation and use.

To select a display

When you connect an external display to the Monitor port, you can toggle the output between the Liquid Crystal Display (LCD), the external monitor, or both devices.

Change text in this variable definition to document title.

Use the Fn+F7 keys to select a display. See also “Selecting the Display Mode” for more information.

<i>To</i>	<i>Press</i>	<i>Result</i>
Switch to an external display	Fn+F7	Toggles between the LCD, the external display connected to the Monitor port, or both the LCD and external display.

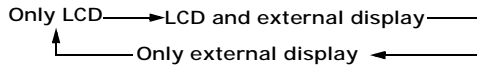

 Connect the cable before you turn on the notebook, otherwise Fn + F7 will not work.

Connecting a USB Device

You can connect a Universal Serial Bus (USB) device such as an external mouse, keyboard, speaker, and microphone to your notebook.

To connect a USB device

 The following steps describe the procedure for connecting a USB mouse to your notebook.

Refer to the manual that came with your USB device for specific installation instructions.

- ❑ Locate the USB device identified by the Ψ symbol. Plug one end of the USB cable into this port and the other end into the USB device.

Connecting USB device to USB port

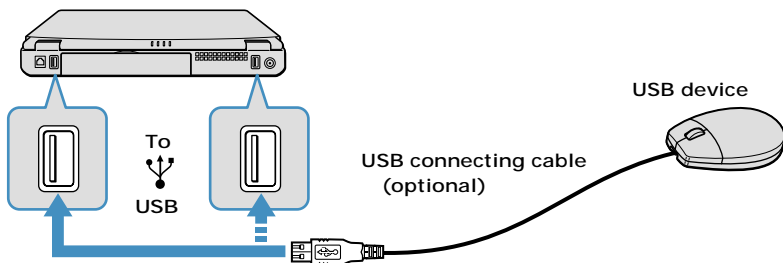

You can use an optional Sony USB mouse such as the PCGA-UMS1 series (optional) with this notebook. Since the USB mouse software driver is preinstalled in the notebook, you simply plug the USB mouse into the USB port to use it. One USB port supports one USB device.

 See the manual that came with your USB device for more information on its installation and use.

Connecting an i.LINK Device

You can connect an i.LINK enabled digital video camera recorder to the i.LINK®* S400  (IEEE1394) port.



You can purchase compatible i.LINK cables from your local retailer, from the Sony VAIO® [sonystyle Web site \(http://vaio.sonymstyle.com\)](http://vaio.sonymstyle.com), or by calling 1-888-315-7669 (toll free).

To connect a digital video camera recorder

- Plug one end of the i.LINK cable (optional) into the i.LINK port on the left side of the notebook and the other end into the DV In/Out port on the digital video camera recorder.

Connecting digital video camera recorder to i.LINK port

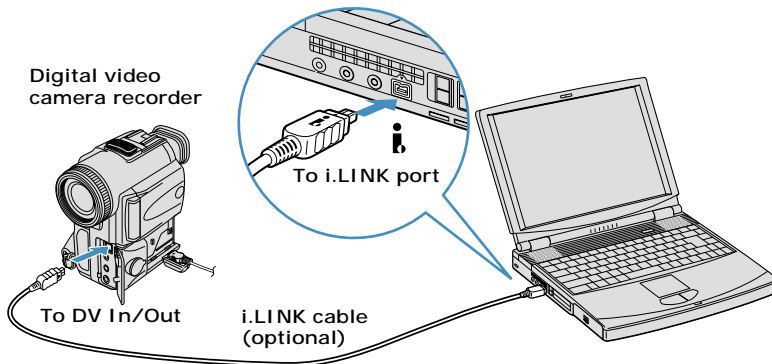

* i.LINK is a trademark of Sony used to designate that a product contains an IEEE 1394 connector. The i.LINK connection may vary, depending on the software application, operating system, and compatible i.LINK devices. All products with an i.LINK connection may not communicate with each other. Refer to the documentation that came with your compatible i.LINK device for more information on operating conditions and proper connection. Before connecting compatible i.LINK PC peripherals to your system, such as a CD-RW or hard disk drive, confirm their operating system compatibility and required operating conditions.

Notes on connecting an i.LINK device

- ❑ The above figure displays a connection to a Sony digital video camera recorder; your digital video camera recorder may need to be connected differently.
- ❑ Only Sony digital video camera ports labeled “DV In/Out” or “i.LINK” are i.LINK-compatible.
- ❑ See the manual that came with your digital video camera recorder for more information on its installation and use.
- ❑ Do not connect more than one digital video camera at a time. The software supplied with your notebook will not recognize multiple cameras.
- ❑ The i.LINK port on the notebook does not supply power to external devices. If the external device requires power from the i.LINK port, you cannot use the device with the notebook.
- ❑ The notebook supports transfer rates up to 400 Mbps; however, the actual transfer rate is the lowest transfer rate of the external device.
- ❑ The i.LINK features available may vary depending on the software applications you use. See the documentation that accompanied your software for more information.

i.LINK cables compatible with your VAIO notebook include cables with the following part numbers: VMC-IL4415 (a 1.5-meter cable with a 4-pin connector at each end) and VMC-IL4615 (a 1.5 meter-cable with a 4-pin connector at one end and a 6-pin connector at the other). You can purchase these cables from your local retailer, through the Sony VAIO® sonystyle Web site (<http://www.sonystyle.com/vaio>), or by calling 1-888-315-7669 (toll free).

Connecting with another VAIO computer

You can use an optional i.LINK®* cable to connect your VAIO notebook to another computer that has the preinstalled Microsoft® Windows® XP operating system or the Sony Smart Connect software. You can use an i.LINK cable (not supplied) to connect the two computers and then use one computer to edit, copy or delete files on the other computer. You can also print from a printer attached to either computer.

Connecting with an i.LINK cable

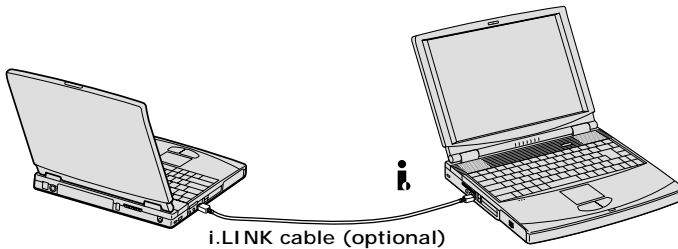

When you connect two VAIO computers, you must assign each computer a unique name. The computers can be identified by this unique name when the two computers are networked together.

If you have previously purchased a VAIO computer or notebook that does not have Smart Connect 3.0 software preinstalled, consult the Sony Web site for support options (<http://www.sony.com/pcsupport>).

* i.LINK is a trademark of Sony used to designate that a product contains an IEEE 1394 connection. The i.LINK connection may vary, depending on the software applications, operating system, and compatible i.LINK devices. All products with an i.LINK connector may not communicate with each other. Refer to the documentation that came with your compatible i.LINK device for information on operating conditions and proper connection. Before connecting compatible i.LINK PC peripherals to your system, such as a CD-RW or hard disk drive, confirm their operating system compatibility and required operating conditions.

Connecting External Speakers

You can enhance the sound quality of your notebook by connecting external speakers. See the manual that came with the speakers for more information on their installation and use.



Do not place floppy disks on the speakers; the speakers' magnetic field can damage the data on floppy disks.

Before connecting external speakers

- Make sure that the speakers are designed for computer use.
- Turn down the volume of the speakers before you turn them on.

To connect external speakers

- 1 Locate the Headphone jack identified by the  symbol on the left side of the notebook.
- 2 Plug the speaker cable into this jack.

Connecting speakers to the headphone jack

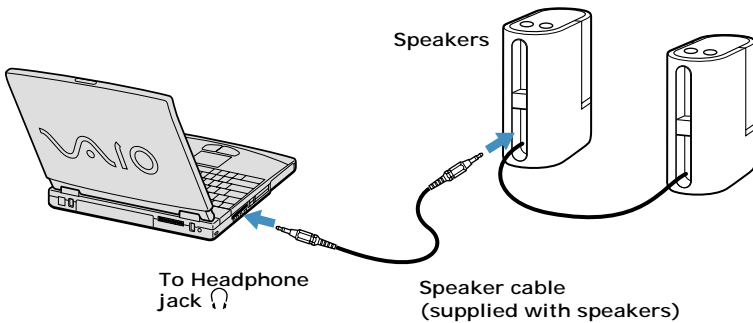

Connecting an External Microphone

You can enhance the quality of sound input by using an external microphone. See the manual that came with the microphone for more information on its installation and use.

 Make sure your microphone is designed for notebook use. The microphone should be compliant with the plug-in power microphone.

To connect an external microphone

- 1 Locate the Microphone jack identified by the  symbol on the left side of the notebook. A protruding dot above the Microphone jack further distinguishes this jack from other jacks and ports.
- 2 Plug the microphone cable into the Microphone jack.

Connecting microphone to microphone jack

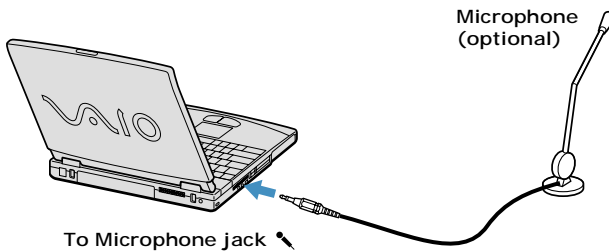

Expanding Your Notebook Capabilities

The following peripheral devices can be connected to your notebook, to expand the capabilities of your computer and enhance its versatility to meet your various business or personal needs:

- A Personal Digital Assistant (PDA)
- A Wireless LAN Access Point
- A Wireless LAN PC Card



For more information on available Sony products, go to <http://www.sonymstyle.com/vaio>.

Personal Digital Assistant

A handheld PDA is the quintessential personal planner and entertainment center that fits in your pocket. With a PDA, you can easily perform the following functions:

- Enter your schedule details in the calendar and view them by the day, week, or month, and even set an alarm to remind you of important events.
- Keep your contact names, addresses, phone numbers, and other details in the address book, and find them when you need them.
- Add tasks to the To Do List, prioritize them, and assign them due dates.
- Synchronize your data with the software on your notebook, to back up your data.
- Track expenses when you are out of the office, then transfer the data to your notebook.
- Exchange data with your notebook.

Wireless LAN Access Point

The Wireless LAN Access Point is designed for building a wireless Local Area Network (LAN) environment. The Access Point comes with the Wireless LAN PC Card and required software. You can easily build a wireless LAN environment by plugging the Access Point into an AC power outlet, installing the Wireless LAN PC Card in your notebook, and using the provided software. Because a wireless LAN configuration requires no wiring, you can operate multiple computers more freely than ever before.

Change text in this variable definition to document title.

You can also connect your Access Point to a telephone line, Integrated Services Digital Network (ISDN) router, cable modem, or Digital Subscriber Line (xDSL) modem to share access to the Internet among multiple computers.

Wireless LAN PC Card

The Wireless LAN PC Card, which comes with the Wireless LAN Access Point, can be purchased separately and is designed for building a wireless LAN environment. The Wireless LAN PC Card can be used with or without the Access Point. With the Access Point, you can build a wireless LAN between computers that are equipped with the Wireless LAN PC Card and gain access to the Internet. Without the Access Point, you can achieve direct communication (Peer to Peer mode) between computers.



For information on available Sony products, go to <http://www.sonystyle.com/wirelesslan>.

Customizing Your VAIO Notebook

The following sections briefly describe how to change your notebook's default settings.

- ❑ Selecting the Display Mode
- ❑ Changing the window design of Sony software

Selecting the Display Mode

This notebook uses the ATI video controller. You can select which display is used when the notebook is connected to an external monitor. When you connect an external display, you can switch the display mode between your notebook's LCD display and the external monitor.

- 1** Click the Start button and then point to Control Panel.
- 2** Click Display to access the Display Properties window.
- 3** Click the Settings tab, and then click the Advanced button. The "(Multiple Monitors) and ATI RAGE MOBILITY-M1 AGP ..." dialog box appears.

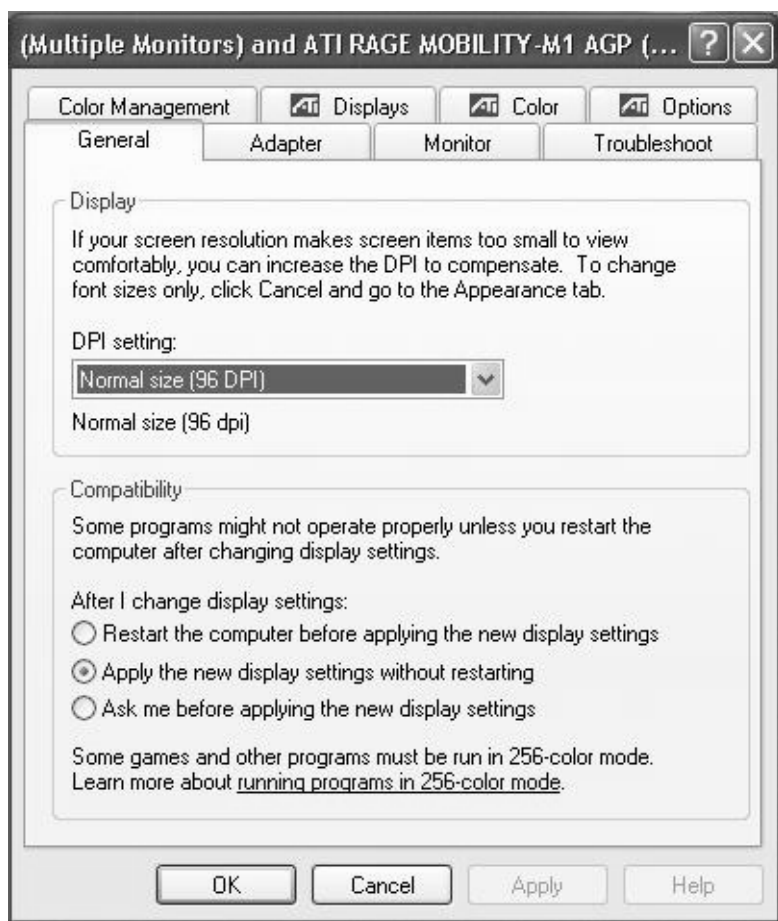

(Multiple Monitors) and ATI RAGE MOBILITY-M1 screen



Change text in this variable definition to document title.

- 4 Click the Displays tab and select the display settings by clicking the  icon on the panel of your display choice. For more information, click the Help button.



If you cannot see your movie or DVD on the external display, change the monitor or TV setting by clicking on the Secondary  icon and changing it to Primary .



You may not be able to display the notebook LCD screen and an external display or projector at the same time, depending on the types of computer displays and projectors you are using.

Turn on the notebook after you connect the external display.

Changing the window design of Sony software

To change the window design

- 1** Click the Start button, then click Control Panel.
- 2** In the left navigation window, click “Switch to Classic View.”
- 3** Double-click UI Design Selector.
- 4** Click << or >> and select the desired design.
- 5** Click Apply. The “UI Design Selector” window design changes. The window design for your Sony software will match the “UI Design Selector” window.
- 6** To try another selection, click << or >> then click OK to close the UI Design Selector.



This feature is available with UI Design Selector-compatible software only.

Change text in this variable definition to document title.

Adding Memory

In the future you may want to install memory modules to expand the functionality of your notebook. The amount of memory on your notebook will vary depending on the model you purchased. See the Specifications flyer that came with your notebook for the amount of memory pre-installed. Expansion memory modules are available as options. For memory upgrades, use only PC100 (CL2) SDRAM SO-DIMMs (gold lead contacts). This section describes how to replace memory modules in your computer:

- Precautions and Procedures
- Typical expansion memory configuration
- Removing a memory module
- Removing a memory module
- Viewing the amount of memory

Precautions and Procedures

The procedures described below assume that you are familiar with the general terminology associated with personal notebooks and with common safety practices required for using and modifying electronic equipment. Personal injury or equipment damage may result from failure to take these precautions.



Make sure you observe the proper safety precautions when you install memory modules in your notebook. See the bulleted list below. Be careful when adding memory. Mistakes made when installing or removing a memory module may cause a malfunction.

- ❑ Disconnect your system from its power source and from any telecommunications links, networks, or modems before you open the system or follow any of the procedures described below. Personal injury or equipment damage may result from failure to take these precautions.
- ❑ Electrostatic discharge (ESD) can damage memory modules and other components. Perform the procedures described below only at an ESD workstation. If such a station is not available, do not work in a carpeted area, and do not handle materials that produce or hold static electricity (cellophane wrappers, for example). Ground yourself by maintaining contact with an unpainted metal portion of the chassis while performing the procedure.
- ❑ Do not open the memory module package until you are ready to install the module. The package protects the module from ESD.
- ❑ Use the special bag for preventing ESD or use aluminum foil when you store the memory module.

Typical expansion memory configuration

Models with 128 MB memory

Total System Memory (MB)	Slot 1 (MB)	Slot 2 (MB)
128	128	
192	128	64
256	128	128
384	128	256
512	256	256

Models with 256 MB memory

Total System Memory (MB)	Slot 1 (MB)	Slot 2 (MB)
256	128	128
384	128	256
512	256	256

Removing a memory module

- 1 Shut down your notebook and disconnect all peripheral devices, such as your printer.
- 2 Unplug your notebook and remove the battery pack(s).
- 3 After your notebook has cooled, loosen and remove the screw that secures the cover of the memory bay on the bottom of your notebook. Use an appropriate screwdriver.

Removing the memory module cover

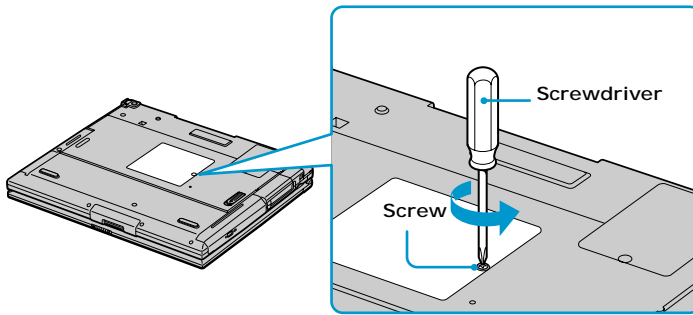

- 4 Touch a metal object (such as the connector panel on the back of your notebook) to discharge any static electricity.

- 5 Remove the memory module.

Removing memory module

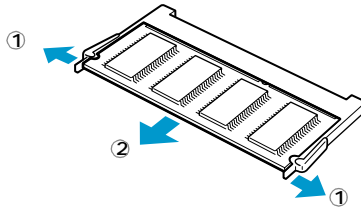

- ① Pull the tabs in the direction of the arrow . The memory module is released .
- ② Pull the memory module in the direction of the arrow.

- 6 Tighten the screw on the memory bay cover.



Your notebook comes with a memory module installed in the memory slot. To upgrade your memory, removal of these modules may be necessary before installing your upgrade memory module.

Installing a memory module

- 1 Follow steps 1 to 4 of “Removing a memory module” for removing the preinstalled memory.
- 2 Remove the new memory module from its packaging.
- 3 Install the memory module by sliding it into the memory module slot. Press the module into place until it clicks.

Installing memory module

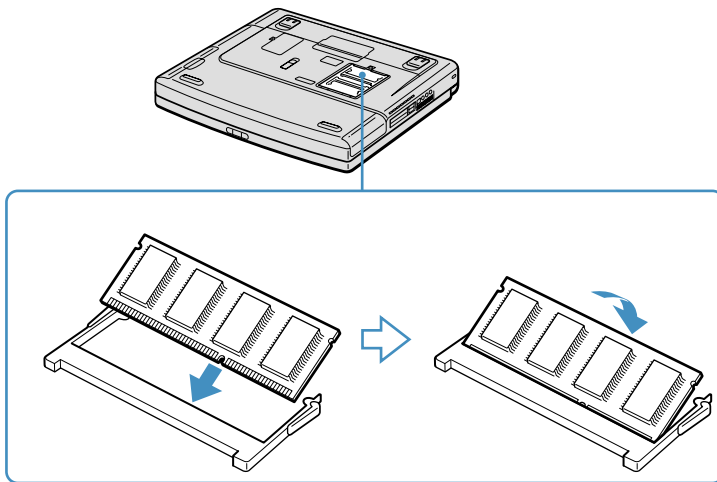

1 Slide the memory module into the slot.

2 Press the module into place until it clicks.

- 4 Tighten the screw on the cover of the memory bay.

Viewing the amount of memory

- 1** Restart the notebook.
- 2** Click Start, right click My Computer, and then click Properties. The System Properties window appears.

Change text in this variable definition to document title.

- 3 Click the General tab. The amount of memory (MB of RAM) is shown.

System Properties window



- 4 If the additional memory is not shown, repeat the steps described in the "Removing a memory module" section.

About the Software on Your Notebook

Your VAIO® notebook is ready to help you work, play, learn, and communicate as soon as you turn it on. This section provides the following information:

- ❑ An overview of the various software that come with your notebook and the activities you can perform with your software
- ❑ Details on your Sony application, driver, and system recovery CDs

Software Overview



Depending on the configuration of your notebook, all software listed below may not be supplied.

Adobe Acrobat Reader™

Adobe Systems Inc.

Acrobat Reader software enables you to view, navigate, and print electronic documents in Adobe Portable Document Format (PDF), an open file format that is intended to preserve the fidelity of documents created on all major computer platforms.

Adobe eBook Reader

Adobe Systems Inc.

Adobe eBook Reader enables you to read high-fidelity eBooks on your computer. This reader software displays eBooks with the pictures, vivid graphics, and rich fonts expected from printed books. The program combines exceptional reading experience with an intuitive interface.

Adobe Photoshop® Elements

Adobe Systems Inc.

Using state-of-the-art image editing tools, you can unleash your artistic ability and create digital images for print, e-mail and posting to the Web. The versatile image capturing options allow you to start working with digital and traditional photos immediately. Explore endless creative possibilities for your personal images with Adobe Photoshop Elements.

Apple QuickTime™

Apple Computer Inc.

QuickTime is the Apple technology that makes video, sound, music, 3D, and virtual reality come alive for our Internet browser and Windows.

Digital Print

Sony Electronics Inc.

This image management software makes it fun and easy to edit, import, and organize your digital pictures in a photo album for rich digital printing to any standard color laser or inkjet printer. Digital Print can also be used to make custom CD labels for your audio CDs.

DVgate™

Sony Electronics Inc.

Connect a compatible digital video camera recorder to the i.LINK®* connector and capture your own video clips and still images. You can edit clips from your video, add others, and combine clips into new movie segments. You can also save your images in a variety of popular file formats.

EarthLink™ Network Total Access

EarthLink Network Inc.

An Internet Service Provider that supplies access, information, and assistance to its customers, introducing them to the Internet. Member benefits include e-mail, newsgroups, a Personal Start Page, a free 6 MB Web site, a member magazine, and 24-hour technical support.

Microsoft® Internet Explorer

Microsoft Corp.

Internet Explorer delivers the Web the way you want it. It is safe, easy to use, and you can personalize how you access the Web. Outlook Express and other tools in Internet Explorer also help you have a great experience when you are on the Web.

Microsoft Office XP Professional/Small Business (on selected models)

Microsoft Corp.

With Microsoft Office XP you'll find a powerful new technology that will help you get work done more quickly by providing real-time, context-sensitive options for important actions, from formatting to error correction. Task panes consolidate important tasks into a single integrated view, enabling you to conduct searches, launch and format documents, and view the contents of your Clipboard from one location.

* i.LINK is a Sony trademark used only to designate that a product contains an IEEE 1394 connection. The i.LINK connection may vary, depending on the software applications, operating system, and compatible i.LINK devices. All products with an i.LINK connection may not communicate with each other. Refer to the documentation that came with your compatible i.LINK device for information on operating conditions and proper connection. Before connecting compatible i.LINK PC peripherals to your system, such as a CD-RW or hard disk drive, confirm their operating system compatibility and required operating conditions.

Microsoft® Word

Microsoft Corp.

Microsoft Word makes it easy to create shared Web, e-mail, and print documents for use around the world. It embraces HTML as a first-class file format and extends Word's ease-of-use to the Web and e-mail. Word also extends that ease-of-use to international users, making it simple to create multilingual documents.

MovieShaker™

Sony Electronics Inc.

Sony's original MovieShaker software creates personal movies that have transitions, background music and text. Just import your video clips and "shake" with a click of the mouse. Your personal movies are easy to create and fun to share with family and friends.

Norton AntiVirus™

Symantec Corporation

Norton AntiVirus provides security for your Internet and e-mail communications. This powerful antivirus software works in the background to continuously protect your PC, by scanning the files you download from the Web and receive as e-mail attachments. Each time you connect to the Internet, Norton Antivirus updates its virus definitions to deliver automatic protection today and in the future.

PC-Cillin®

Trend Micro, Inc.

PC-Cillin provides portable, easy-to-use, real-time antivirus security at your computer's entry point (beaming, synchronization, Internet access) to defend against potential threats hidden inside files, e-mail, or on the Web.

PictureGear™

Sony Electronics Inc.

This image management software displays images from your hard drive, a Sony digital still camera, or a Sony Mavica® camera. The images appear in a convenient light-table format, so that you can easily view the contents of an entire folder.

Quicken®*Intuit Inc.*

Quicken is a fast, easy way to organize your finances. Quicken works just like your checkbook, so it is easy to learn and use. Quicken manages all your finances, bank accounts, credit cards, investments, and loans. You can even pay your bills online.

RealJukebox*Real Networks Inc.*

RealJukebox is one of the world's most widely used personal music management systems. Using RealJukebox, you can capture the contents of a music CD, manage and play back your music, and view various music-related information via the Internet. This Custom RealJukebox for Sony allows seamless check-out capabilities to a wide range of Sony personal audio devices, and offers convenient links to Sony product and music service home pages.



If you are using an external CD-ROM drive connected with a PC Card, be sure to connect your external CD-ROM drive before starting RealJukebox. Additionally, do not remove your CD-ROM drive while using RealJukebox. Either of these actions may cause RealJukebox to shut down improperly.

RealPlayer®*Real Networks Inc.*

RealPlayer is the RealNetworks video and audio player which lets you access 2,500 radio stations featuring music, news and sports.

Smart Capture*Sony Electronics Inc.*

Smart Capture is a fun new way to send multimedia messages via e-mail. Smart Capture manages the i.LINK® connection between your computer and a Sony Digital Handycam® Camcorder that supports the i.LINK interface. It allows you to capture compressed video or still images that you can save or share via e-mail. A smart solution to computer, digital audio/video and network convergence.

SonicStage

Sony Electronics Inc.

This new jukebox application adds a host of new features to its predecessor, OpenMG™ Jukebox. Continuing to take advantage of Sony's copyright-protected ATRAC3™ format for high-quality digital audio storage, SonicStage sports a new Music Visualizer, a sleek new player skin design, audio CD burning capability, and a parametric equalizer for fine-tuning audio playback.

Sony Style Connect

E-Solutions

SonyStyle Connect provides excellent dial-up, as well as DSL, Internet connection services. To find out which plan is best for you, visit <http://www.sonystyleconnect.com> and find out what is available in your area.

VAIO Support Agent

Sony Electronics Inc.

VAIO Support Agent provides immediate, interactive online support.

VisualFlow™

Sony Electronics Inc.

VisualFlow software is a state-of-the-art Sony multimedia browser designed specifically for Memory Stick® media. It displays any still picture, movie, or sound file stored in a Memory Stick media in a visually pleasing, artistic manner. VisualFlow software not only plays a selected movie or sound file, but also enables playback of files by other applications such as PictureGear, Memory Stick Slideshow, and Windows Explorer.

WinDVD®

InterVideo Inc.

WinDVD is a simple-to-use DVD player including all the features you would expect to find in a standard consumer DVD player, while also offering advanced display and navigation features such as zoom, pan, bookmark, and time search.

Application, Driver, and System Recovery CDs

Your notebook comes with the following application and system recovery CDs. To use your recovery CDs, see “Using Your Recovery CDs” for more information.

Application Recovery CD(s)

Sony Electronics Inc.

This CD enables you to reinstall individual applications if they become corrupted or are erased.

Driver Recovery CD(s)

Sony Electronics Inc.

This CD enables you to reinstall individual device drivers if they become corrupted or are erased.

System Recovery CD(s)

Sony Electronics Inc.

This CD enables you to format the C:\ partition of the hard disk drive, then reinstall the operating system and software titles that shipped with your notebook, if they become corrupted or are erased. Use it to restore the hard disk of the VAIO® Notebook you purchased. This CD restores your notebook to its original state, therefore user data and applications will be lost.

Using Your Recovery CDs

The following sections describe how to use the Application Recovery, Driver Recovery, and System Recovery utilities.

To use the Application Recovery CD(s)

The Application Recovery CD(s) allows you to reinstall individual applications if they become corrupted or are accidentally erased. Reinstalling an individual software title may correct a problem you are experiencing with your notebook or software application; you may not need to reinstall the entire contents of your hard drive. If you need to reinstall all the software titles that shipped with your notebook, use the System Recovery CD(s). See “To use the System Recovery CD(s)” for more information. If you have any questions on using the Application Recovery CD, contact Sony Customer Support.



You must be in Windows to run the Application Recovery CD. If you have any questions on using the Application Recovery CD, contact Sony Customer Support.

- 1** Turn on your notebook. If your notebook is already on, close all applications.
- 2** When the Windows desktop appears, insert the Sony Application Recovery CD in the optical drive. The Application Recovery utility loads automatically.
- 3** When the Application Recovery menu appears, select the icon for the application you want to restore and then follow the on-screen instructions to complete the recovery process.



Your system may include one or two Application Recovery CDs. If you have two Application Recovery CDs, insert the first CD to run the Application Recovery program. You may be prompted to insert the second CD, depending on the application you wish to restore.

To use the Driver Recovery CD(s)

The Driver Recovery CD utility enables you to reinstall individual drivers if they become corrupted or are erased. You can reinstall an individual driver to correct a problem that you are experiencing with your notebook, hardware, or software application. VAIO Support Agent, an application repair utility, uses a vault feature on the Driver Recovery CD(s) to repair software applications.



If you need to reinstall all of the software applications that shipped with your computer, use the System Recovery CD.

You must be in Windows to run the Driver Recovery CD utility.

Reinstalling specific drivers with the Driver Recovery CD

- 1** Turn on your notebook. If your notebook is already on, close all applications.
- 2** When the Windows desktop appears, insert the Driver Recovery CD in the optical disc drive.
- 3** Click Start in the Windows taskbar, and then Control Panel. The Control Panel window appears.
- 4** Click Performance and Maintenance, and then System. The System Properties dialog box appears.
- 5** From the Hardware tab, click Device Manager.

Change text in this variable definition to document title.

- 6 Click to highlight the unknown device (identified by a yellow question mark) or the device for which you wish to reinstall the driver.

Device Manager screen

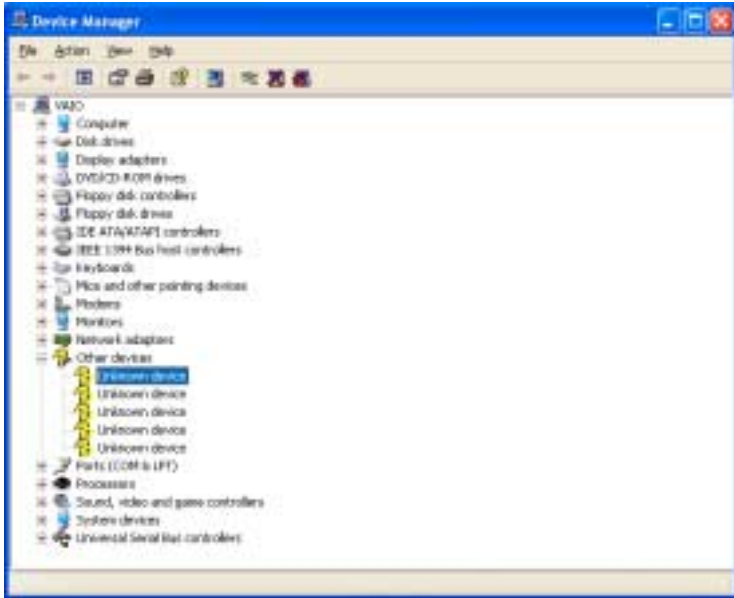

- 7 From the Action menu, click Uninstall. This will remove the device driver from your system. Click OK to confirm this action. Repeat as necessary.
- 8 Restart your computer. To restart, click Start in the Windows taskbar, Turn Off Computer, and then click Restart.
- 9 When the Windows desktop reappears, Windows will automatically reinstall the device drivers from the Driver Recovery CD.

Reinstalling all drivers with the Driver Recovery CD

- 1** Turn on your computer. If your computer is already on, close all applications.
- 2** When the Windows desktop appears, insert the Driver Recovery CD into the optical disc drive.
- 3** Click Start in the Windows taskbar, and then Control Panel. The Control Panel window appears.
- 4** Click Performance and Maintenance, then System. The System Properties dialog box appears.
- 5** From the Hardware tab, click Device Manager.
- 6** Click to highlight the device for which you wish to reinstall the driver.

Change text in this variable definition to document title.

- 7 From the Actions menu, choose Properties. The Properties dialog box for that device appears

Properties dialog box



- 8 Click Reinstall Driver. The Hardware Update Wizard appears.
- 9 Click next. The wizard will search for the correct driver on your Driver Recovery CD.
- 10 When the recovery process is complete, click Finish. Some drivers will require that you restart the computer to complete installation.

To use the System Recovery CD(s)



This CD restores your notebook to its original state, therefore user data and applications will be lost.

You can use the System Recovery CD(s) to reinstall the operating system and software titles that shipped with your notebook if they become corrupted or erased. You may not need to reinstall the entire contents of your hard drive. If you experience a problem with your notebook, reinstalling an individual device driver or software title may correct the problem. Use the Application Recovery CD(s) to reinstall individual applications or use the Driver Recovery CD(s) to reinstall device drivers. See “To use the Application Recovery CD(s)” for more information.

The System Recovery CD contains a backup copy of all the software originally installed on your hard disk drive. It can be used only to recover the hard disk of the notebook you purchased.

The System Recovery utility will perform a Full Restore with Format. It formats the hard disk drive, then restores all the original software.



Full Restore with Format removes all the information on the hard disk drive. You will lose any software you have installed and any other files you have created since you started to use your notebook. This means you will have to reinstall any applications that were not included with the notebook when you purchased it. If you have any questions on using the System Recovery CD, contact Sony Customer Support.

- 1 Insert the Sony System Recovery CD in the optical drive.
- 2 Shut down your notebook as described in the “Shutting Down Your Notebook” section of your printed Quick Start.
- 3 Wait four seconds and turn on your notebook.
- 4 Click OK to signify you have read and accept the Microsoft End-User License Agreement.
- 5 When the System Recovery menu appears, follow the on-screen instructions to complete the recovery process.

If your notebook does not start from the Recovery CD

- 1** Press the power button and hold it for more than four seconds to turn off the notebook.
- 2** Turn on the notebook. When the Sony logo is displayed, press the F2 key. The BIOS setup menu screen appears.
- 3** Press the arrow keys to select the Exit menu.
- 4** Press the arrow keys to select “Get Default Values” and then press the Enter key. The message “Load default configuration now?” appears.
- 5** Check that “Yes” is selected, then press the Enter key.
- 6** Press the arrow keys to select “Exit” (Save Changes) and then press the Enter key. The message “Save configuration changes and exit now?” appears.
- 7** Check that “Yes” is selected, then press the Enter key. The notebook restarts from the Recovery CD.



Your system may include one or two System Recovery CDs. If you have two System Recovery CDs, insert the first CD to run the System Recovery program. You are prompted to insert the second CD once the information from the first CD has been installed.

The recovery process takes from 30 minutes to 60 minutes to complete.

After recovering your system using the System Recovery CD(s), you may be prompted to insert your Application Recovery CD(s) after restarting Windows. Insert the Application Recovery CD to automatically complete recovery of your system.

Troubleshooting

This section describes how to solve common problems you may encounter when using your notebook. Many problems have simple solutions, so try these suggestions before you contact Sony PC Support (<http://www.sony.com/pcsupport>).

- Troubleshooting Your Notebook
- Troubleshooting the LCD Screen
- Troubleshooting the Mouse and Touchpad
- Troubleshooting Drives, PC Cards and Peripheral Devices
- Troubleshooting Software
- Troubleshooting the Modem
- Troubleshooting Audio
- Troubleshooting the Printer
- Troubleshooting i.LINK devices

Troubleshooting Your Notebook

My notebook does not start.

- Check that the notebook is plugged into a power source and that it is turned on. Check that the power indicator on the front panel of the notebook indicates that the power is on.
- Check that the battery packs are inserted properly and that they are charged.
- Make sure there is no floppy disk in the floppy disk drive.
- Confirm that the power cord and all cables are connected firmly, as described in the “Connecting a Power Source” section of the printed Quick Start.
- If you plugged the notebook into a power strip or Uninterruptible Power Supply (UPS), make sure the power strip or UPS is turned on and working.

Change text in this variable definition to document title.

- ❑ If you are using an external display, check that it is plugged into a power source and turned on. Check that the brightness and contrast controls are adjusted correctly. See the manual that came with the display for details.
- ❑ Condensation may cause the notebook to malfunction. If this occurs, do not use it for at least one hour.
- ❑ Take the battery pack out of the notebook, unplug the power cord, plug it in again, and then turn on the power.

My notebook starts but a BIOS error appears.

- ❑ When the internal backup battery is low on power, it may not start your system properly. The message, “Press <F1> to resume, <F2> to setup” appears at the bottom of the screen. Follow these steps:
 - 1 Press F2. The BIOS Setup menu appears.
 - 2 Set the date (month/day/year). Press Enter.
 - 3 Press ↓ to select System Time, and then set the time (hour: minute: second). Press Enter.
 - 4 Press → to select Exit, and then press ↓ to select Get Default Values. The message “Load default configuration now?” appears.
 - 5 Select Yes and then press Enter.
 - 6 Select Exit (Save Changes), and then press Enter. The message “Save Configuration changes and exit now?” appears.
 - 7 Select Yes, and then press Enter. The notebook restarts.



If this occurs on a regular basis, contact Sony PC Support (<http://www.sony.com/pcsupport/>).

My notebook starts, but the message “Operating system not found” appears and Windows does not start.

- ❑ Make sure there is no floppy disk in the floppy disk drive (non-bootable).
- ❑ If a non-bootable floppy disk is in a connected floppy disk drive, follow these steps:
 - 1 Turn off the notebook, and then remove the floppy disk.

- 2 Restart the notebook and confirm that Windows starts properly.
- ❑ If Windows still does not start, follow the steps below to start the BIOS:
- 1 Turn off the notebook.
 - 2 Remove any peripheral devices connected to the notebook.
 - 3 Turn the notebook on again.
 - 4 Press the F2 key when the Sony logo appears. The BIOS setup menu screen appears.
 - 5 Press the arrow keys to select the Exit menu.
 - 6 Press the arrow keys to select “Get Default Values” and then press Enter. The message “Load default configuration now?” appears.
 - 7 Select Yes, and then press Enter.
 - 8 Use the directional arrow keys to select “Exit” (Save Changes), and then press Enter. The message “Save configuration changes and exit now?” appears.
 - 9 Select Yes, and then press Enter. The notebook restarts.

If your notebook continues to display the message “Operating system not found,” and Windows does not start, use your supplied System Recovery CD to restore the software titles shipped with your notebook. See “To use the System Recovery CD(s)” for more information.



The System Recovery CD restores your notebook to its original state, therefore user data and applications will be lost.

My notebook stops responding or does not shut down.

It is best to shut down your notebook using the Shut Down command on the Windows Start menu. Using other methods, including those listed here, may result in loss of unsaved data.

- ❑ Try restarting the notebook. On the Windows taskbar, click Start, select Turn Off Computer, and then click Turn Off.
- ❑ If you cannot restart as described in the preceding step, you can restart the notebook by pressing Ctrl+Alt+Delete simultaneously and then clicking Turn Off on the Windows Security screen.

Change text in this variable definition to document title.

- ❑ If the previous step does not work, press and hold the power button for at least four seconds. This turns off the power.
- ❑ If your notebook stops responding while playing a CD or DVD, stop the CD/DVD, restart the notebook by pressing Ctrl+Alt+Delete simultaneously, and then clicking Turn Off on the Windows Security screen.
- ❑ Unplug the notebook from the AC adapter and remove the battery pack from your notebook.

 Pressing Ctrl+Alt+Delete simultaneously or turning off the notebook with the power switch may result in data loss in files that are currently open.

The power management setting is not responding.

Your notebook's operating system may become unstable if it is interrupted or if you attempt to make changes before the notebook completely enters a lower power state, such as Hibernate.

- ❑ To restore the notebook to its normal operating stability:
 - 1 Close all open applications.
 - 2 Restart the notebook by pressing Ctrl+Alt+Delete simultaneously and then selecting Restart from the drop-down list.

 If this procedure does not work, press and hold the power button for four seconds or longer to shut down the notebook.

Why does the System Properties dialog box display a slower CPU speed than advertised?

This is normal. Because your computer's CPU utilizes some type of CPU speed controlling technology, System Properties may display the CPU's current speed instead of the maximum advertised speed.

Troubleshooting the LCD Screen

My LCD screen is blank.

- Check that the notebook is plugged into a power source and that it is turned on.
- Check that the power indicator on the notebook is on.
- Check that the battery pack is inserted properly and that it is charged.
- The notebook may be in LCD (Video) Standby mode. Press any key to activate the screen.
- The display mode may be set to external display mode. Press and hold the Fn key while pressing F7 several times.

My LCD screen continues to show the previous screen.

Press the Windows key and the D key twice to refresh the screen.

The image on my connected external display is not centered or sized properly.

Use the controls on your external display to adjust the image. See the manual that came with your display for more information.

I want to change the video resolution of my display.

Follow this procedure to change the video resolution of your display.

- Click Start, point to Control Panel, and then click the Display icon. The Display Properties dialog box appears.
- Click on the Settings tab.
- Move the Screen Area slider to change your video resolution.

I cannot switch the LCD display to TV, and vice versa.

- Make sure that the TV is connected, configured, and powered on correctly before starting the notebook. See “Selecting the Display Mode” for more information.

Troubleshooting the Mouse and Touchpad

My mouse does not work.

- ❑ If you are using an external mouse, check that the mouse is plugged into the mouse connector. See “Connecting a PS/2 External Mouse or Keyboard” for more information.
- ❑ If you are using an optional Sony USB mouse PCGA-UMS1 series, check that the mouse is plugged into the USB port.
- ❑ If you are still experiencing problems, use your supplied Driver Recovery CD to reinstall the mouse drivers. See “To use the System Recovery CD(s)” for more information.

My touchpad does not work properly.

- ❑ You must restart the notebook to make the touchpad work again.
- ❑ If your touchpad is interpreting a single tap as a double-click, you must adjust the button assignments. Follow these steps:
 - 1 Press the Windows key and use the arrow keys to select Control Panel, and then Mouse.
 - 2 Change the button assignments in the Mouse Properties dialog box. (One of the buttons is assigned to the double-click action.)
- ❑ If you are still experiencing problems, check that another mouse was not installed.
- ❑ You may need to use your Driver Recovery CD to reinstall the mouse drivers. See “To use the System Recovery CD(s)” for more information.

The pointer does not move while using the Touchpad or Mouse.

- ❑ Press the Windows key and use the arrow keys to select Shut Down. When the Shut Down Windows dialog box appears, press Enter.
- ❑ If you cannot turn off your notebook as described in the step above, press Ctrl+Alt+Delete simultaneously and then click Shut Down on the Windows® Security screen to restart the notebook.
- ❑ If you cannot restart your notebook as described in the step above, press and hold the power button for more than four seconds to turn off the notebook.

- ❑ If the pointer does not move while playing a disc, press Ctrl+Alt+Delete simultaneously to stop playback and restart the notebook.
- ❑ If you are still experiencing problems, check that another mouse was not installed.
- ❑ You may need to use your supplied Driver Recovery CD to reinstall the touchpad or mouse drivers. See “To use the System Recovery CD(s)” for more information.

Troubleshooting Drives, PC Cards and Peripheral Devices

My floppy disk drive cannot write to a floppy disk.

- ❑ Check that the floppy disk drive is properly inserted into the multipurpose bay. See “To reinsert the floppy disk drive” for more details.
- ❑ If the floppy disk is write-protected, disable the write-protect feature or use a floppy disk that is not write-protected.

My optical disc drive is not playing my CD or DVD properly.

- ❑ Check that the label of the disc is facing up.
- ❑ If the disc requires software, check that the software is installed according to the manufacturer’s instructions.
- ❑ A dirty or damaged disc may cause the notebook to stop responding while it tries to read the disc. If necessary, restart the notebook, remove the disc, and then check it for dirt or damage.
- ❑ If you see video but cannot hear audio, check all of the following:
 - ❑ Check that your optical drive does not have the mute setting enabled.
 - ❑ Check the volume setting in the audio mixer.
 - ❑ If you are using external speakers, check the volume settings, and then check the connections between your external speakers and the notebook.
 - ❑ Click Start, point to Control Panel, System, and then Device Manager. Check that the correct drivers are installed properly.
- ❑ Do not use adhesive labels to identify the CD. The label may come off while the disc is in use in the optical drive and cause the drive to malfunction.
- ❑ If a region code warning appears when you try to use your optical drive, it may be that the DVD you are trying to play is incompatible with the optical drive. Check the region code listing on the DVD packaging.
- ❑ Condensation may cause the notebook to malfunction. If this occurs, do not use it for at least one hour.

My optical drive tray does not open.

- ❑ Check that the notebook is turned on.
- ❑ Press the Eject button on the optical drive.
- ❑ If the Eject button does not work, open the tray by inserting a thin, pointed object (such as a paper clip) in the hole to the right of the Eject button.

I cannot use Digital Video (DV) devices. The message “DV equipment seems to be disconnected or turned off” appears.

- ❑ Check that the DV device is turned on and that the cables are properly connected.
- ❑ If you are using multiple i.LINK®* devices, the combination or order of the devices may be causing the problem. In this case, turn off your notebook and all connected devices. Disconnect the devices that are not in use. Check the connections for each device, and then restart your notebook.

My PC Card is not working.

- ❑ Check that the PC Card is installed properly.
- ❑ Check that the PC Card is compatible with Microsoft® Windows®.
- ❑ Check that any necessary drivers were installed properly. See “To use the System Recovery CD(s)” for more information on installing the drivers.

* i.LINK is a Sony trademark used to designate that a product contains an IEEE 1394 connection. The i.LINK connection may vary, depending on the software applications, operating system, and compatible i.LINK devices. All products with an i.LINK connector may not communicate with each other. Refer to the documentation that came with your compatible i.LINK device for information on operating conditions and proper connection. Before connecting compatible i.LINK PC peripherals to your system, such as a CD-RW or hard disk drive, confirm their operating system compatibility and required operating conditions.

Troubleshooting Software

My software program stops responding or crashes.

Contact the software publisher or designated provider for technical support. Refer to “Application, Driver, and System Recovery CDs” for more information.

When I click an application icon, the message “You must insert the application CD into your optical drive” appears and the software does not start.

- ❑ Some titles require specific files that are located on the application CD. Insert the disc and try starting the program again.
- ❑ Make sure you place the CD in the tray with the label side facing up.

I cannot use the DVgate™ software.

Connect your notebook to AC power when using DVgate software.

My computer’s start-up time seems longer after I have installed AOL. What can I do?

On some computers, installing America Online® (AOL) may increase boot time by up to a minute. If you experience this on your system and would like to speed up the time required to start your computer, you may want to disable the AOL WAN driver. Do the following:

- 1 Click Start in the Windows® taskbar and select Control Panel.
- 2 Click Network and Internet Connections, and select Network Connections.
- 3 Right-click on the Local Area Connection with device name “WAN Network Driver,” and select Disable.

Verify that your AOL connection still functions satisfactorily with the WAN Network Driver disabled. If you need to reverse this setting, repeat the steps above and select Enable.

Troubleshooting the Modem

My modem does not work.

- ❑ Check that the phone line is plugged into the line jack. See “Connecting a Phone Line” for more information.
- ❑ Check that the phone line is working. You can check the line by plugging in an ordinary phone and listening for a dial tone.
- ❑ Check that the phone number the program is dialing is correct.
- ❑ Check that the software you are using is compatible with the notebook’s modem. (All preinstalled Sony programs are compatible.)
- ❑ If you are still experiencing problems, use your supplied Driver Recovery CD to reinstall the modem drivers. See “To use the System Recovery CD(s)” for more information.

My modem connection is slow.

Your notebook is equipped with a V.90/K56flex-compatible modem. Many factors may influence modem connection speed, including telephone line noise or compatibility with telephone equipment (such as fax machines or other modems). If you think your modem is not connecting properly to other PC-based modems, fax machines, or your Internet Service Provider (ISP), check the following:

- ❑ Ask your phone company to check that your phone line is free from any line noise.
- ❑ If your problem is fax-related, check that there are no problems with the fax machine you are calling and that it is compatible with fax modems.
- ❑ If you are having a problem connecting with your Internet Service Provider, check that the ISP is not experiencing technical problems.
- ❑ If you have a second phone line available, try connecting the modem to that line.

Troubleshooting Audio

My speakers make no sound.

- ❑ If the built-in speakers are turned off, press Fn+F3 to turn on the speakers. If the speaker volume is turned to the minimum, press Fn+F4, and then press **↑** or **→** to increase the volume.
- ❑ If nothing is displayed when you press Fn+F3 or Fn+F4:
 - 1 Double-click System in Control Panel.
 - 2 Set the sound device to enable in Device Manager.
- ❑ If your notebook is powered by batteries, check that the battery packs are inserted properly and that they are charged.
- ❑ If you are using an application that has its own volume control, check that the volume is turned up.
- ❑ Check the volume controls in the Windows® taskbar.
- ❑ If you connect external speakers, check that the speakers are properly connected and the volume is turned up. If the speakers have a mute button, make sure it is off. If the speakers are powered by batteries, check that the batteries are inserted properly and that they are charged.
- ❑ If you have connected an audio cable to the Headphone jack, disconnect the cable.
- ❑ If you are still experiencing problems, use the supplied Driver Recovery CD to reinstall the drivers. See “To use the System Recovery CD(s)” for more information.

My microphone does not work.

If you are using an external microphone, check that the microphone is plugged into the Microphone jack. See “Connecting an External Microphone” for more information.

Troubleshooting the Printer

I cannot print.

- ❑ Your connected printer may not function after the notebook resumes from a power saving mode. If this occurs, follow these steps to reset the printer connection:
 - 1 Click Start and then select Control Panel.
 - 2 Click the Printers folder.
 - 3 Right-click the icon of the printer that is not functioning, and then select Properties to access the Properties window.
 - 4 Click OK to close the Properties window. The printer should now function properly.
- ❑ Verify that the parallel port is set to the proper mode.
 - 1 Restart your computer, and then press the F2 key when the Sony logo screen appears. The BIOS setup menu appears.
 - 2 Press the Esc key.
 - 3 Select LOAD BIOS DEFAULTS, and then press Enter.
 - 4 Select EXIT SAVING CHANGES, and then press Enter.
 - 5 Press Enter again. The BIOS defaults are reset and the parallel port configuration is set to default values.

Troubleshooting i.LINK devices

I cannot establish a connection between two VAIO computers when using an i.LINK cable.

- 1** Disconnect the i.LINK® * cable from both computers and reconnect it.
- 2** Wait for the computers to respond. If neither computer responds after a few moments, restart both computers.



The computers may not recognize an i.LINK connection after returning from a power saving mode (Standby or Hibernate). If that happens, restart the computers to establish a connection.

* i.LINK is a Sony trademark used only to designate that a product contains an IEEE 1394 connection. The i.LINK connection may vary, depending on the software applications, operating system, and compatible i.LINK devices. All products with an i.LINK connection may not communicate with each other. Refer to the documentation that came with your compatible i.LINK device for information on operating conditions and proper connection. Before connecting compatible i.LINK PC peripherals to your system, such as a CD-RW or hard disk drive, confirm their operating system compatibility and required operating conditions.

Getting Help

Sony provides you with several support resources to answer questions about your VAIO® notebook or the preinstalled software. Refer to these resources in the order they are listed.

Support Options

If you have questions about your notebook or the preinstalled software, refer to the following sources for answers in the sequence listed below.

1 *VAIO® Notebook User Guide*

The online VAIO® Notebook User Guide and the printed VAIO® Notebook Quick Start provide you with information on how to maximize your notebook capabilities and solve common problems. The quick start is supplied with your notebook.

2 **Software Manuals and Online Help Files**

The software preinstalled on your notebook may come with an online manual. These manuals are stored on the hard disk drive as online Help files. You can find the Help files from the Help menu under the specific software application. Some software applications may come with a printed manual.

3 **Operating System Online Support**

Your notebook comes preinstalled with Microsoft® Windows®. For operating system support, you can access Microsoft® customer support at <http://support.microsoft.com/directory/>.

4 **VAIO Support Agent**

You can find VAIO Support Agent by clicking Start and then selecting Help and Support. Using advanced diagnostic technology, Sony's VAIO Support Agent runs scheduled protections of your applications, network settings, and other important software settings. When your software is protected, you can use VAIO Support Agent to repair software problems by restoring your software to any of the previously protected states.

5 **Sony PC Support**

This service provides instant access to information on commonly encountered problems. Enter a description of your problem and the Knowledge Database searches for the corresponding solutions online. You can access Sony PC Support at: <http://www.sony.com/pcsupport>.

6 Sony Fax-on-Demand

This service, which requires a fax machine or your fax software, provides answers to commonly asked questions. You can use this automated service to request a list of available topics, then select the topics that you want to receive. To contact the Sony fax-on-demand service, call: 1-888-4-SONY-PC (1-888-476-6972).

7 Sony Customer Support

Software support is available free of charge for 90 days after the original date of purchase. You can call and speak with a Sony Customer Support Representative without using your notebook by calling: 1-888-4-SONY-PC (1-888-476-6972).

Software Support Information

Adobe® Acrobat Reader™, eBook Reader, Photoshop® Elements (Adobe Systems Inc.)

Web site	http://www.adobe.com/
phone	206-675-6126 (fee-based support)
fax	206-628-5737
e-mail	techdocs@adobe.com
hours	M-F, 6 AM - 5 PM (PT)

America Online® (America Online, Inc.)

Web site	http://www.aol.com/
phone	800-827-6364
hours	7 days a week, 24 hours a day

EarthLink™ Network Total Access (EarthLink Network Inc.)

Web site	http://support.earthlink.net/
e-mail	support@earthlink.net
phone	800-890-5128 or 800-890-6356
hours	7 days a week, 24 hours a day

Norton AntiVirus® (Symantec Corporation)

Web site	http://www.symantec.com/techsupp/
phone	800-927-3991; 900-646-0007*
hours	M - F, 6 AM - 5 PM (PT)

* Support from 1-800-927-3991 is fee-based per incident. Support from 1-900-646-0007 is fee-based per minute. Online support is free of charge.

PC-Cillin® (Trend Micro, Inc.)

Web site	http://www.antivirus.com/pc-cillin/
phone	949-387-7800
e-mail	support@trendmicro.com
hours	M-F 8 AM - 5 PM (PT)

QuickTime™ (Apple Computer Inc.)

Web site	http://www.apple.com/
phone	512-674-8700
hours	7 days a week, 6 AM - 6 PM (PT)

Real Entertainment Suite (RealNetworks Inc.)

Web site	http://service.real.com/rjoptions.html
e-mail	http://service.real.com/help/call.html (online form)

Sony Applications (Sony Electronics Inc.)

Web site	http://www.sony.com/pcsupport/
phone	888-4-SONY-PC (888-476-6972)*
hours	7 days a week, 24 hours a day

* Support from 1-888-4-SONY-PC is free of charge for 90 days after the original date of purchase.

Windows® Operating System, Word (Microsoft Corporation)

Web site	http://www.sony.com/pcsupport/
phone	888-4-SONY-PC (888-476-6972)*
hours	7 days a week, 24 hours a day

* Support from 1-888-4-SONY-PC is free of charge for 90 days after the original date of purchase.

WinDVD® (InterVideo, Inc.)

Web site	http://www.intervideo.com/jsp/Support.jsp
phone	510-651-0888
e-mail	support@intervideo.com

Sony Service Center

For the Sony Service Center nearest you, call 1-888-4-SONY-PC (1-888-476-6972) or find Sony Customer Service on the Web at <http://www.sony.com/pcsupport>.

Change text in this variable definition to document title.

Index

A

Access Point, Wireless LAN 59

adding

- hardware 39
- memory 67
- peripherals 39
- printers 48–49

Alt key 11

Application Recovery CD 82

Applications key 11

attaching port replicator 41

audio

- connecting external speakers 57
- external microphone 58
- troubleshooting 100

B

battery pack

- power saving modes 34
- using a second 29

battery packs

- charging 30
- indicator lights 13, 29
- removing 29, 31

brightness

- adjusting 14

built-in speakers

- See also speakers 14

buttons

- Eject 21

C

cameras

- digital video recorder 54

canceling commands 11

Caps Lock

- indicator light 13

CD/DVD discs

- ejecting 22
- inserting 21

CD-RW/DVD Combo Drive or DVD-ROM drive 21

charging battery packs 30

coin-operated telephones 36

computer 104

- connecting to another 56
- customizing 61
- expanding capabilities of 59
- troubleshooting 89

connecting

- another computer 56
- coin-operated telephones 36
- digital video recorder 54
- external speakers 57
- hard drives 26
- i.LINK device 54
- Local Area Network (LAN) 37
- microphone 58
- monitor 50
- multimedia computer display 51
- multiple phone lines 36
- network 26
- party phone lines 36
- PBX 36
- phone line 36
- port replicator 40, 41
- printer 48–49
- projector 51
- PS/2 keyboard 46

- PS/2 mouse 46
- USB device 53
- weight saver 32
- correction keys 11
- Ctrl key 11
- cursor-movement keys 11
- customizing your computer 61
- D**
- digital video camera 54
- disconnecting port replicator 44
- display
 - mode 62
 - options 51
 - selecting 51
- Driver Recovery CD 83
- drives
 - installing additional hard disk 26
 - optical 21
- DV In/Out 54
- E**
- Eject button 21, 22
- ejecting
 - battery packs 31
 - CD/DVD discs 22
 - weight saver 33
- Escape key 11
- expanding your notebook capabilities 59
- expansion memory configuration 69
- external devices
 - display 51
 - display, see also monitor 50
 - speakers 14, 57
- external display
 - connecting 50
- F**
- floppy disk drive
 - troubleshooting 96
- Fn key 11
 - combination commands 14
- function keys 11
- G**
- getting help 103
- H**
- hard drives
 - indicator light 13
 - installing additional 26
- hardware
 - online support 104
- help 103
- Hibernate mode 34
- I**
- i.LINK 54
 - connecting 54
- IEEE-1394 54
- indicator lights 13
 - battery 13, 29
 - Caps Lock 13
 - hard disk 13
 - Num Lock 13
 - Scroll Lock 13
- indicators 13
- Insert key 11
- installing
 - hard drives 26
 - hardware 39
 - memory module 70
 - peripherals 39
- K**
- keyboard
 - key combinations 12, 14
 - PS/2 46
 - using 10
- L**
- LAN
 - see Local Area Network

- LCD
 - selecting to display output 51
 - troubleshooting 93
- Local Area Network
 - connecting 37
- M**
- memory
 - adding 67
- memory module
 - expansion 69
 - installing 70
 - removing 70
- microphone
 - connecting 58
 - troubleshooting 100
- modem
 - troubleshooting 99
- monitor
 - connecting 50
 - selecting 51
 - switching among 15
- mouse
 - PS/2 46
 - troubleshooting 94
- Mouse Properties screen 17
- Mouseware
 - accessing help 17
 - features 17
- multimedia computer display 51
- multiple phone lines 36
- N**
- navigation keys 11
- network
 - connecting 26
- Num Lock
 - indicator light 13
- O**
- operator keys 11
- optical disc drive
 - closing tray 22
 - opening tray 21
- optical discs
 - ejecting 22
- optical drive
 - using 21
- optical drive tray
 - troubleshooting 97
- output devices
 - adding 48–49
- P**
- party phone lines 36
- PBX 36
- PC Card
 - inserting 26
 - troubleshooting 96, 97
 - using 26
 - Wireless LAN Access Point 59
- PDA 59
- peripheral devices
 - troubleshooting 96
- Personal Digital Assistant 59
- phone
 - connecting line 36
- port replicator
 - connecting 40, 41
 - disconnecting 44
 - lever 44
- ports
 - printer 48–49
 - Serial port 40
- power 13
- power saving modes 34
 - Hibernate 34
 - Normal mode 34
 - Standby 34
- Print Screen key 11
- printer

- connecting 48–49
- port 48–49
- troubleshooting 101

projector 51

PS/2 mouse or keyboard 46

R

Recovery CD 82

removing

- memory module 70

replacing

- battery packs 29

restoring data 82

S

Scroll Lock

- indicator light 13

second battery pack 29

- using 29

selecting

- display 51
- LCD 51
- monitor 51

Serial port 40

setting up your PC

- support 104

Shift key 11

Smart Connect 56

software

- changing window design 65
- Smart Connect 56
- support information 106
- troubleshooting 98

Software list 75

Sony Fax-on-Demand service 105

Sony Service Center 107

speakers

- external 57
- switching 14
- troubleshooting 100

- volume 14

Standby mode 34

support

- software 106

support, technical 103

switching

- display 15
- monitor 15

T

technical support 103

touchpad 16

- troubleshooting 94

troubleshooting 89

- audio 100
- drives, PC Cards, and peripheral devices 96
- LCD 93
- modem 99
- mouse and touchpad 94
- printer 101
- software 98

TV or a video deck 47

TV/VCR 47

U

USB

- connecting 53
- mouse 53
- port 53

using 16

- keyboard 10
- optical drive 21
- second battery pack 29
- touchpad 16
- weight saver 32

using PC Card 26

Using the Floppy Disk Drive 18

V

video camera 54

viewing the amount of memory 73

volume control 14

W

weight saver

 attaching 29

 connecting 32

 removing 33

 using 32

window design of Sony software 62

Windows

 Explorer 12

 Find window 12

 key 11

 key combinations 12

 taskbar 91

Wireless LAN Access Point 59

Change text in this variable definition to document title.