

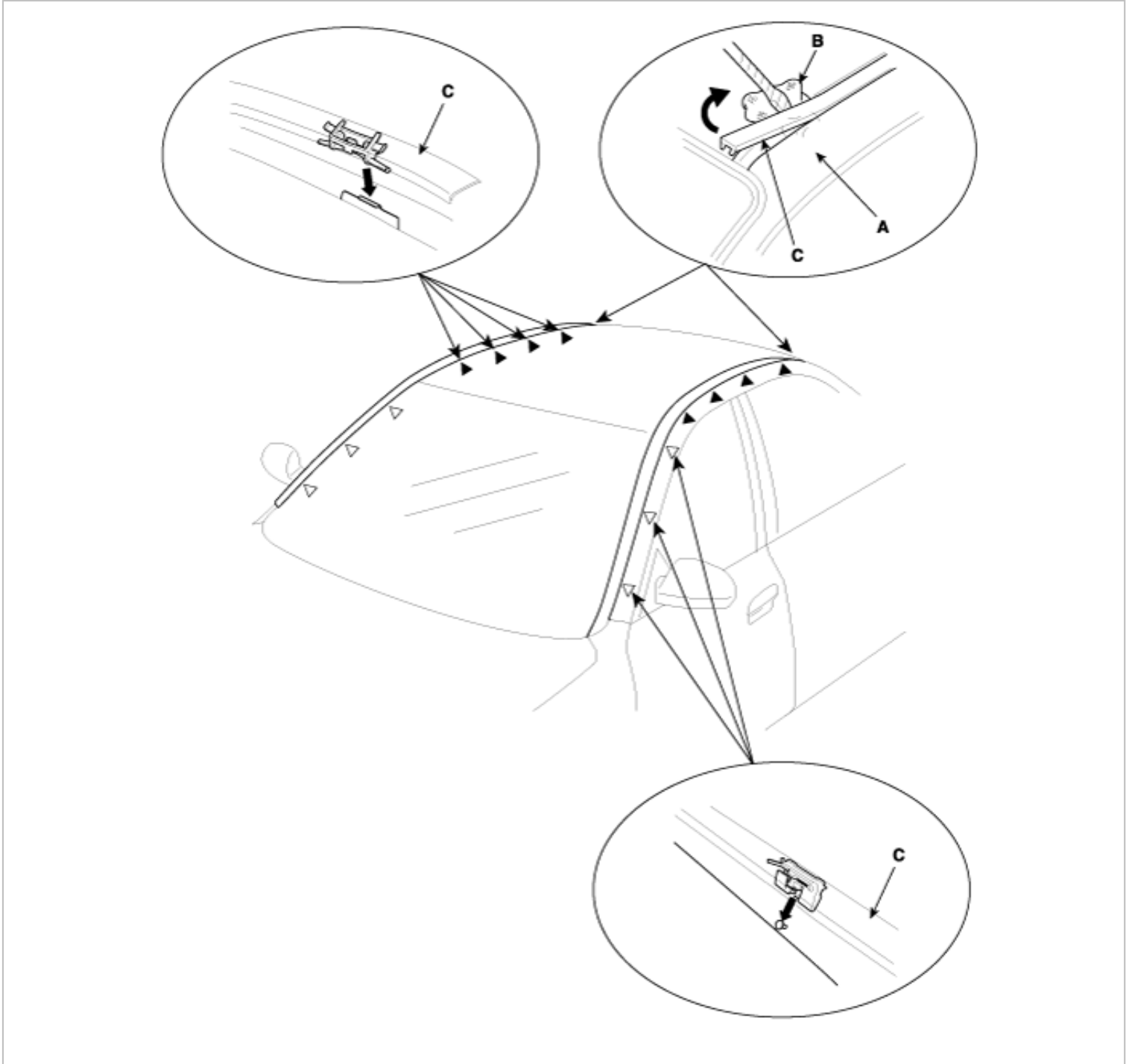

## REPLACEMENT

### ROOF MOLDING REPLACEMENT

1. Apply protective tape to the body (A), using a flat-tip screwdriver wrapped with protective tape (B), pry up on the roof molding (C). Take care not to scratch the body.
2. Pull up the rear portion of roof molding.



3. Install in the reverse order of removal, and note these items:
  - A. Take care not to damage the windshield and rear window moldings.
  - B. Make sure the roof molding is installed securely.

### DOOR MOLDINGS REPLACEMENT

**NOTE**

- Wrap the blade of your putty knife or flat tip screwdriver with protective tape to prevent damage to the door.
- Be careful not to pry too far or you may bend the molding.
- Put on gloves to protect your hands.

1. Prepare to release the molding clips from inside the vehicle.
  - A. To remove the front door molding, remove the front door panel (see page BD- 25).
  - B. To remove the rear door molding, remove the rear door panel (see page BD- 33).
2. Release the clips, and gently pry the front door molding (A) or rear door molding (B) away from the door while removing the adhesive tape.

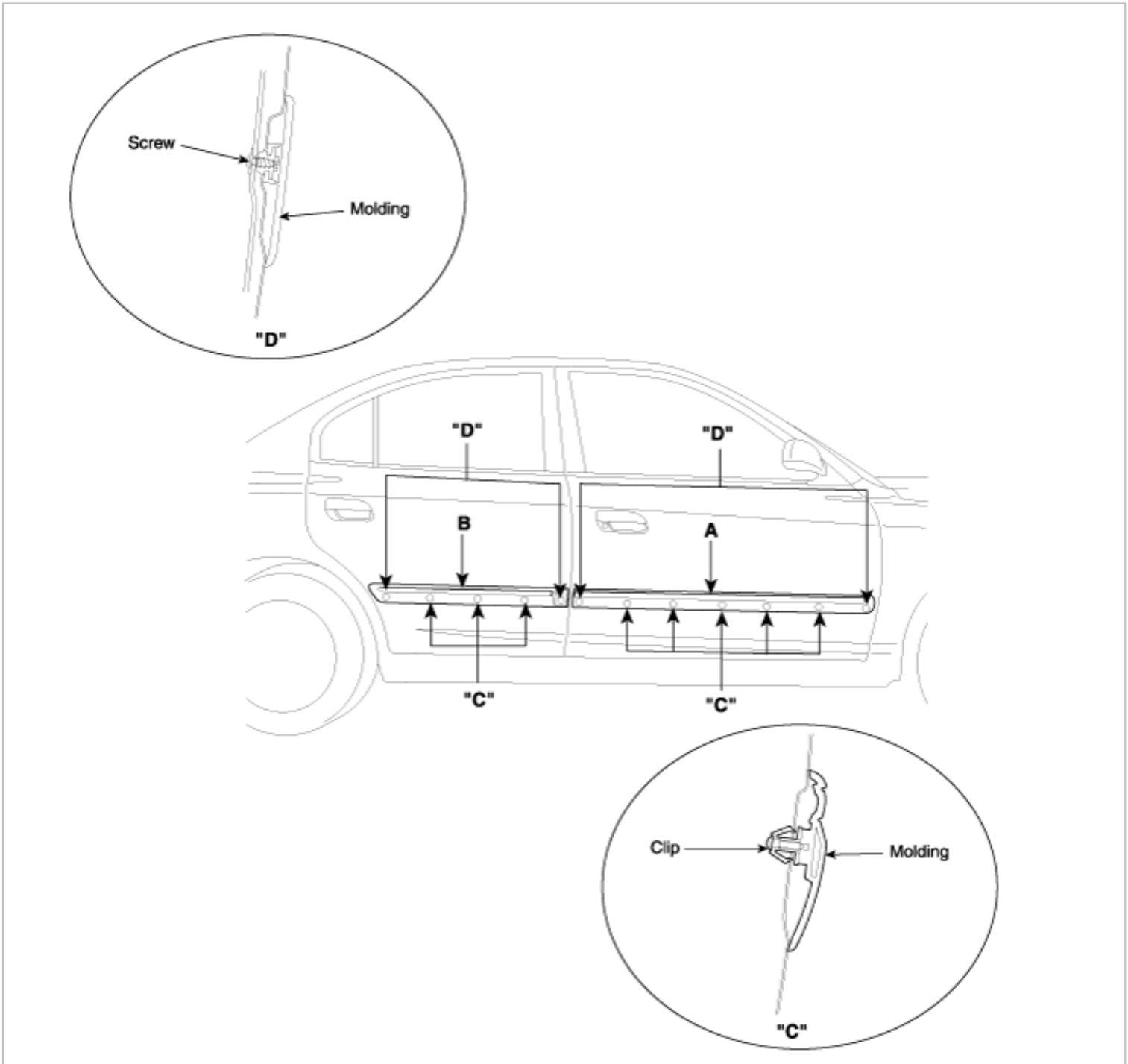

3. Installation is the reverse of removal.  
Replace any damaged clips and adhesive tape.

## SIDE SILL PANEL REPLACEMENT

1. Pull the inner fender back as necessary, and remove the screws (A).
2. Remove the clips (B) from the body.
3. Slide the side sill panel (C) forward and remove it.

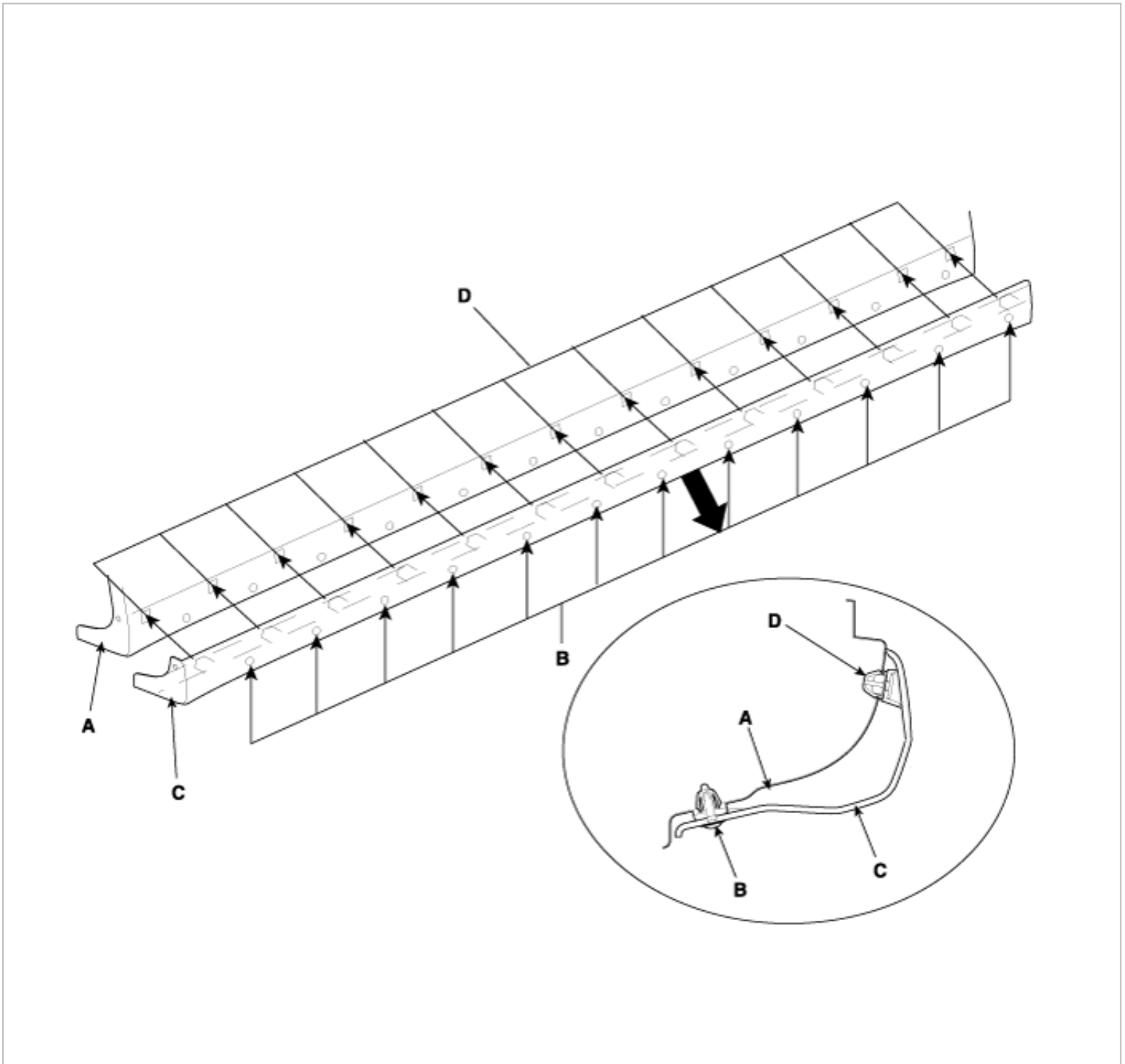

4. Replace any damaged clips.
5. Install the side sill panel.

## WHEEL GUARD REPLACEMENT

1. Remove the wheel guard (A) as shown. Take care not to scratch the body.

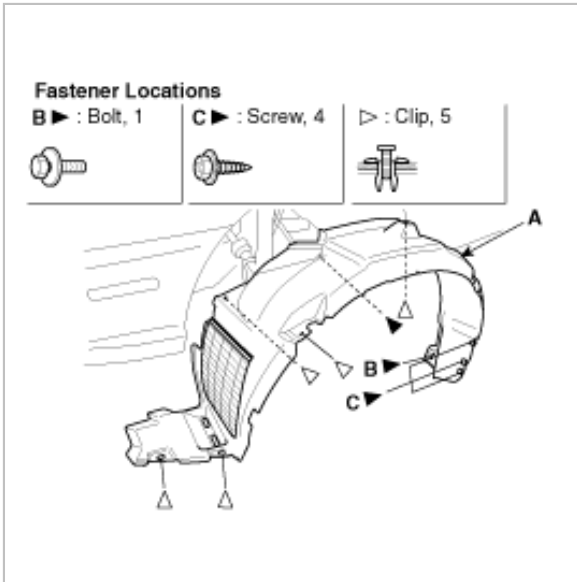

2. Installation is the reverse of removal, and replace any damaged clips.