

BRAKE SYSTEM

Return To Main Table of Contents

GENERAL	2
BRAKE PEDAL	10
MASTER CYLINDER	13
BRAKE BOOSTER	16
BRAKE LINE	18
PROPORTIONING VALVE	19
FRONT DISC BRAKE	20
REAR DRUM BRAKE	27
PARKING BRAKE	34

GENERAL SPECIFICATIONS

Master cylinder	
Type	Tandem
I.D.	22.22 mm (0.875 in.)
Fluid level warning sensor	Provided
Brake booster	
Type	Vacuum
Effective dia.	233.1 mm (9.177 in.)
Boosting ratio	4.0: 1
Proportioning valve	
Cut-in pressure (Split point)	3.92 MPa (40 kg/cm ² , 569 Psi)
Decompression ratio	3.7 : 1
Front brake	
Type	Floating type with ventilated disc
Disc O.D.	257 mm (10.118 in.)
Disc thickness	22 mm (0.866 in.)
Pad thickness	11 mm (0.433 in.)
Cylinder I.D.	54 mm (2.126 in.)
Rear brake	
Type	Leading-trailing drum
Drum I.D.	203.2 mm (8 in.)
Brake lining thickness	4.05 mm (0.159 in.)
Cylinder I.D.	19.05 mm (0.75 in.)
Clearance adjustment	Automatic
Parking brake	
Type	Mechanical brake acting on rear wheels
Braking type	Lever type (Cam shape)
Cable arrangement	V type

SERVICE STANDARD

Standard value

Brake pedal height	178 mm (7.008 in.)
Brake pedal stroke	145 mm (5.709 in.)
Stop light switch outer case to pedal arm clearance	0.5-1.0 mm (0.02-0.04 in.)
Brake pedal free play	3-8 mm (0.118-0.315 in.)
Brake pedal to floorboard clearance	65 mm (2.56 in.) or more
Booster push rod to master cylinder piston clearance	0 (at 500 mmHg vacuum)
Parking brake lever stroke (When lever assembly is pulled with 196 N (20 Kg, 44 lb) force)	7-8 clicks

Service limit

Front disc brake pad thickness	2.0 mm (0.079 in.)
Front disc thickness (minimum)	20 mm (0.787 in.)
Front disc runout	0.04 mm (0.002 in.)
Drum brake lining thickness	1.5 mm (0.059 in.)
Brake drum I.D. (maximum)	205.2 mm (8.079 in.)
Wheel cylinder to piston clearance	0.15 mm (0.006 in.)

TIGHTENING TORQUE

	Nm	kg.cm	lb.ft
Master cylinder to booster mounting nut	8-12	80-120	6-9
Brake booster mounting nut	8-12	80-120	6-9
Brake booster vacuum hose fitting to surge tank	8-12	80-120	6-9
Bleeder screw	7-13	70-130	5-9.5
Brake tube flare nut, brake hose	13-17	130-170	9-12
Proportioning valve mounting nut	8-12	80-120	6-9
Caliper guide rod bolt	22-32	220-320	16-24
Caliper pin bolt	35-45	350-450	26-33
Caliper assembly to knuckle	69-85	690-850	44-63
Brake hose to front caliper	25-30	250-300	18-22
Backing plate mounting bolt	50-60	500-600	37-44

SPECIAL TOOL

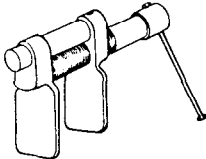
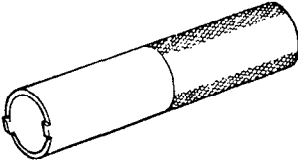
Tool (Number and name)	Illustration	Use
09581-11000 Piston expander		Retraction of the front disc brake piston
09580-34000 Rear brake piston adjuster		Removal and installation of rear brake piston

TROUBLESHOOTING

Symptom	Probable cause	Remedy
Noise or vibration when brakes are applied	Backing plate or caliper improperly mounted Loose backing plate or caliper mounting bolts Unevenly worn or cracked brake drum or brake disc Foreign material in brake drum Seized pad or lining contact surface Excessive caliper to pad assembly clearance Uneven pad contact Lack of lubrication in sliding parts Loose suspension parts	Correct Retighten Replace Clean Replace Correct Correct Lubricate Retighten
Vehicle pulls to one side when brakes are applied	Difference in left and right tire inflation pressure Improper front wheel alignment Inadequate contact of pad or lining Grease or oil on pad or lining surface Drum eccentricity or uneven wear Incorrect wheel cylinder installation Auto adjuster malfunction	Adjust Adjust Correct Replace Replace Correct Correct
Insufficient braking power	Low or contaminated brake fluid Air in brake system Brake booster malfunction Inadequate contact of pad or lining Grease or oil on pad or lining surface Auto adjuster malfunction Overheated brake rotor due to dragging of pad or lining Restricted brake line Proportioning valve malfunction	Replenish or change Bleed the system Correct Correct Replace Correct Correct Correct Replace
Increased pedal stroke (Reduced pedal to floorboard clearance)	Air in brake system Brake fluid leaks Auto adjuster malfunction Excessive push rod to master cylinder clearance	Bleed the system Correct Correct Adjust

Symptom	Probable cause	Remedy
Brake drag	Incomplete release of parking brake Incorrect parking brake adjustment Weak brake pedal return spring Restricted master cylinder return port Broken rear drum brake shoe return spring Lack of lubrication in sliding parts Defective master cylinder check valve or piston return spring Insufficient push rod to master cylinder clearance	Correct Adjust Replace Correct Replace Lubricate Replace Adjust
Insufficient parking brake function	Worn brake lining Grease or oil on lining surface Parking brake cable sticking Auto adjuster malfunction Excessive parking brake lever stroke	Replace Replace Replace Correct Adjust the parking brake lever stroke or check the parking brake cable routing

SERVICE ADJUSTMENT PROCEDURE
BRAKE PEDAL INSPECTION AND ADJUSTMENT

1. Pedal height

Pedal height (from top of pedal to toeboard) A
178 mm (7.008 in.)

If the pedal height is out of specification, adjust by the following procedure.

- 1) Back off the stop lamp switch to a position where it does not contact the pedal arm.
- 2) Turn the stop lamp switch until the clearance between the stop lamp switch outer case and the pedal arm is within the standard value, and tighten the lock nut.

Clearance between pedal and stop lamp switch B
0.5 to 1.0 mm (0.02 to 0.039 in.)

2. Brake pedal free play.

Brake pedal free play C
3-8 mm (0.118-0.315 in.)

3. Start the engine, apply the brake pedal with approximately 50 kg (110 lbs.) of force, and measure the clearance between the brake pedal and the floor board.

Pedal to floor board clearance D
when pedal is depressed 50kg (110lbs.) force
90 mm (3.543 in.) or more
when pedal is fully depressed without brake fluid
60 mm (2.362 in.) or more

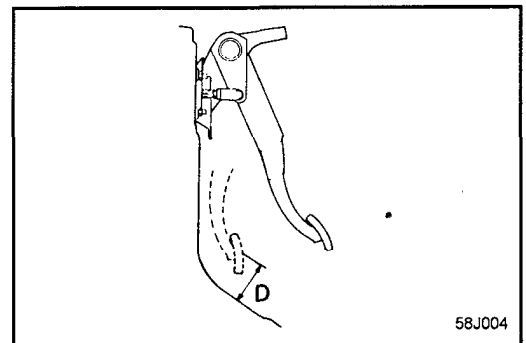
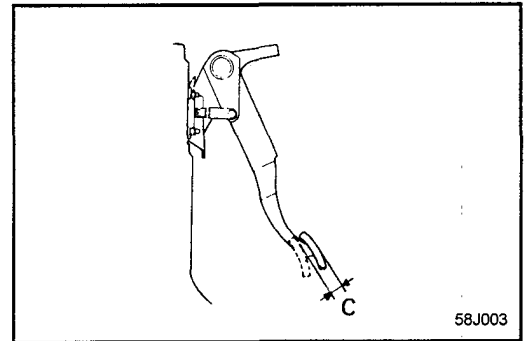
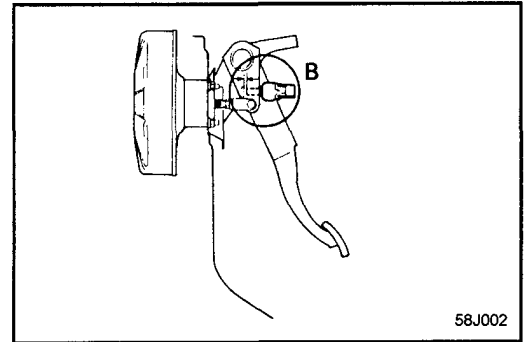
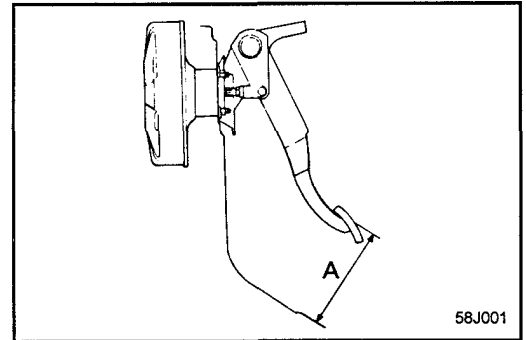

BRAKE BOOSTER OPERATION TEST WITHOUT A TESTER

For a simple check of the brake booster operation, use the following tests.

1. Run the engine for one or two minutes, then stop it. Depress the brake pedal several times using normal foot pressure. If the pedal goes down further the first time, but gradually rises after the second or third time, the brake booster is functioning properly. Go to step 2.
2. With the engine stopped, depress the brake pedal several times. Depress the brake pedal and start the engine. If the pedal goes down slightly, the booster is in good condition. Go to step 3.
3. With the engine running, depress the brake pedal and then stop the engine. Hold the pedal depressed for 30 seconds. If the pedal height does not change, the booster is in good condition.

If one of the above three tests is not okay, check the vacuum hoses, the check valve and the brake booster. Make any necessary corrections. If all the tests are OK, the unit is good.

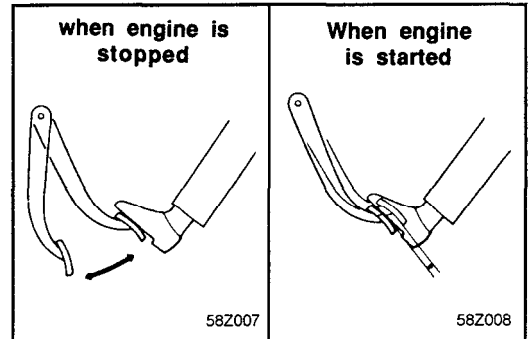
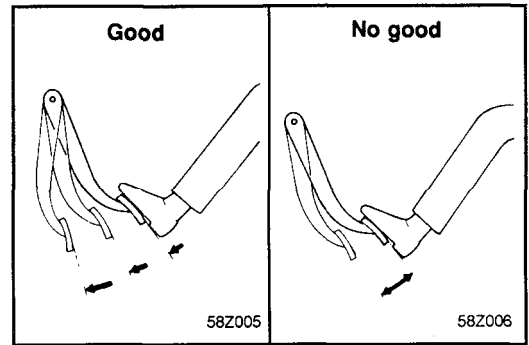

BLEEDING OF BRAKE SYSTEM

1. Remove the reservoir cap and fill the brake fluid reservoir.

CAUTION

Do not allow brake fluid to remain on a painted surface. Wash it off immediately.

NOTE

When bleeding by pressured fluid, do not depress the brake pedal.

2. Connect a vinyl tube to the wheel cylinder bleeder screw and insert the other end of tube in a half full container of brake fluid.
3. Slowly pump the brake pedal several times.
4. While depressing the brake pedal fully, loosen the bleeder screw until fluid starts to run out. Then close the bleeder screw.

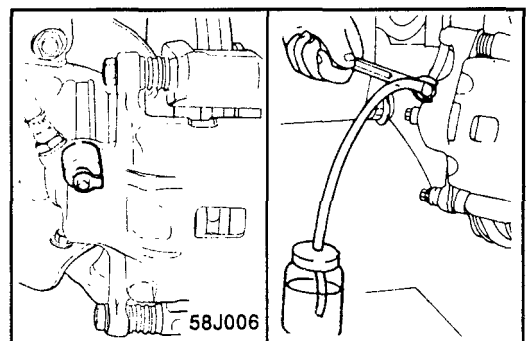
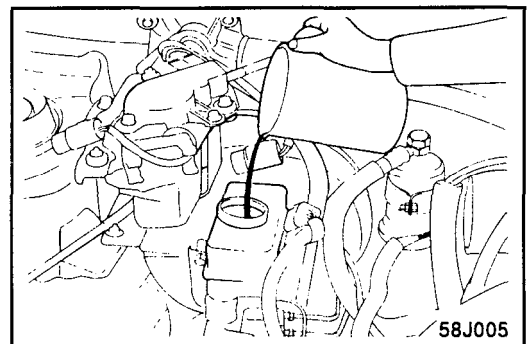

5. Repeat steps 3 and 4 until there are no more bubbles in the fluid.

6. Tighten the bleeder screw.

Bleeder screw tightening torque
7-9 Nm (70-90 kg.cm, 5.1-6.6 lb.ft)

7. Repeat the above procedure for each wheel in the sequence shown in the illustration.

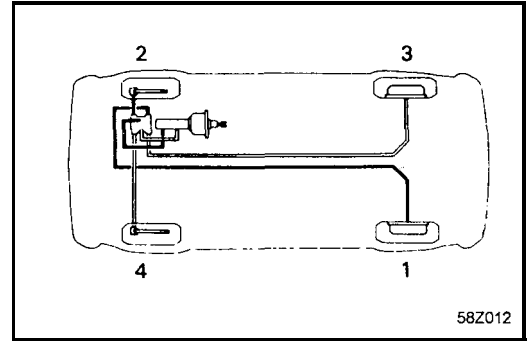

PARKING BRAKE STROKE ADJUSTMENT

1. Pull the brake lever with a force of approximately kg (44 lbs.), and count the number of clicks.

Parking brake lever stroke [Standard value]
7-8 clicks

2. If the number of notches is not within the standard value, adjust the cable length with the adjusting nut of the equalizer.

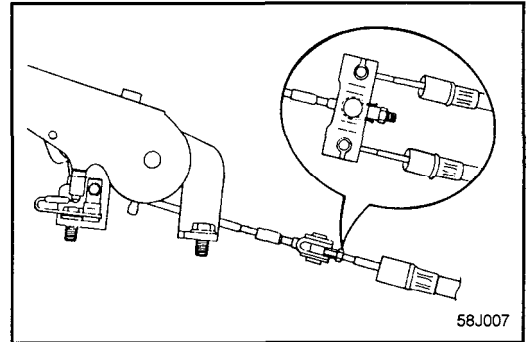

3. The indicator light will go out when the brake lever is fully released, and will light with the lever is pulled up one notch. If it does not operate, check the bulb and/or switch.

4. After the adjustment, check that the rear brakes do not drag with the parking brake lever released.

BRAKE PEDAL

COMPONENTS

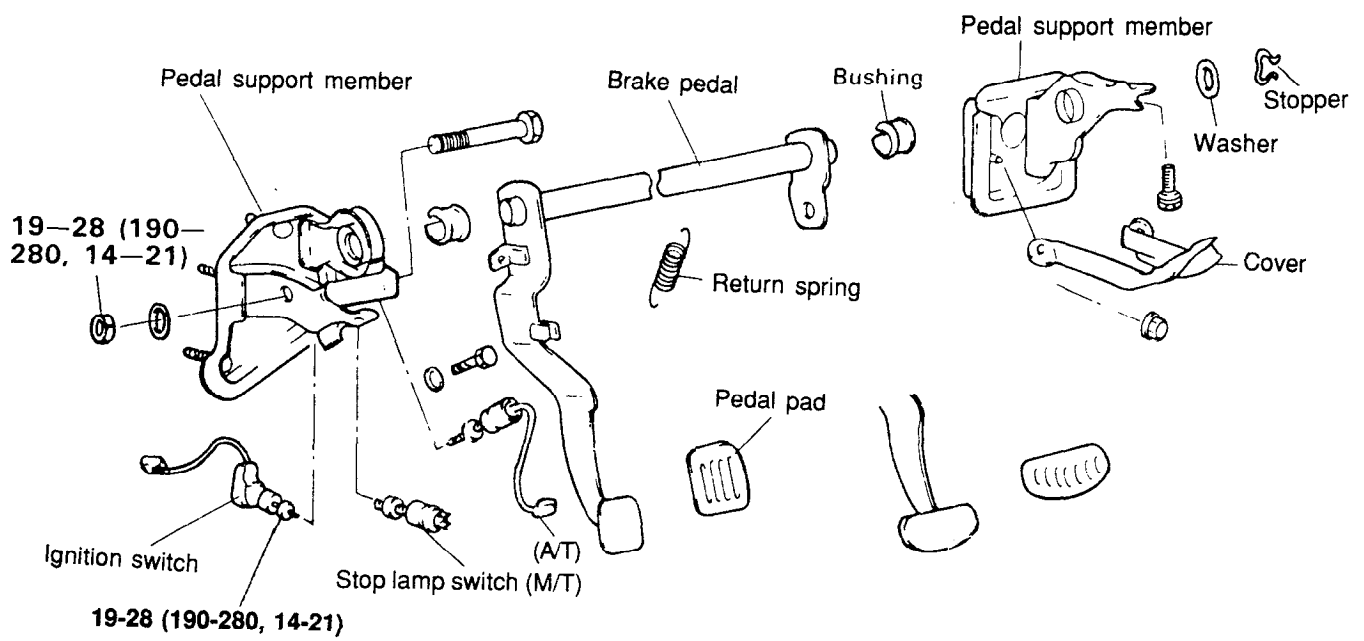

REMOVAL

1. Remove the lower crash pad assembly.
2. Remove the steering column shaft mounting bolts (Refer to Steering Group).
3. Remove the clutch pedal assembly.
4. Remove the console assembly (Refer to Body Group)
5. Remove the glove box housing cover and RH side lower crash pad.
6. Remove the blower switch and air duct control assembly.
7. Drain the coolant, disconnect the heater hose and remove the heater unit assembly (Refer to Air Conditioning Group).
8. Remove the stop lamp switch connector.
9. Remove the return spring.
10. Disconnect the operating rod and brake pedal from each other.

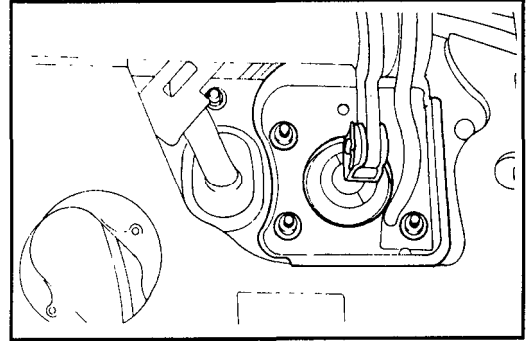

11. Remove the stopper and the washer.

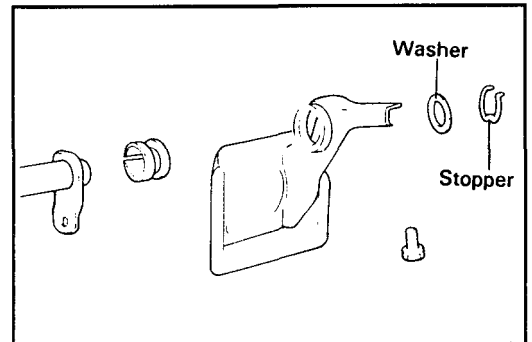

12. Loosen the booster mounting nut and remove the right side pedal support member.
13. Remove the pedal support (left) and remove the pedal from the left.

INSPECTION

1. Check the bushing for wear.
2. Check the brake pedal for distortion.
3. Check the brake pedal return spring for damage.
4. Check the stop lamp switch.
 - 1) With an ohmmeter connected to the stop lamp switch terminals, check for continuity.
 - 2) If there is no continuity when the plunger is depressed and there is continuity when the plunger is released, the stop lamp switch is normal.

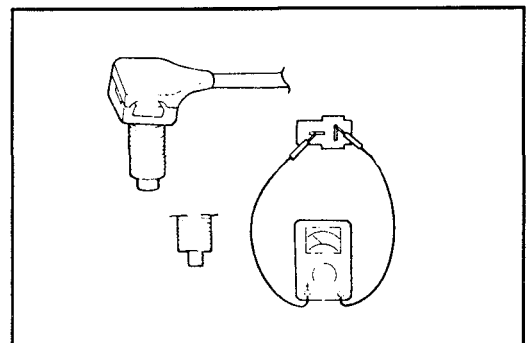

INSTALLATION

1. Apply chassis grease to the bushing bore and flanges.

NOTE

Install the bushing in the correct position as shown in the illustration.

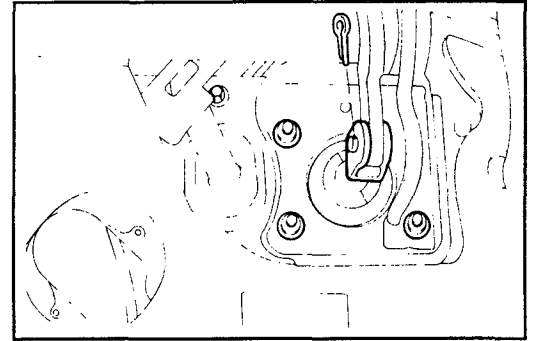

2. Apply chassis grease to the sliding surface of the brake pedal and operating rod clevis pin.

CAUTION

Be sure to install the split pin on the operating rod clevis pin.

3. Adjust the brake pedal height and free play.
4. Adjust the clutch pedal stroke and free play.
5. Install the steering shaft.

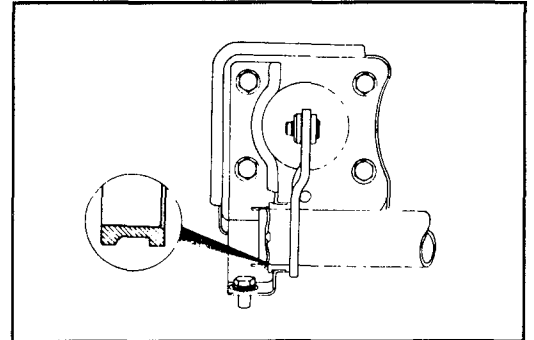

MASTER CYLINDER

COMPONENTS

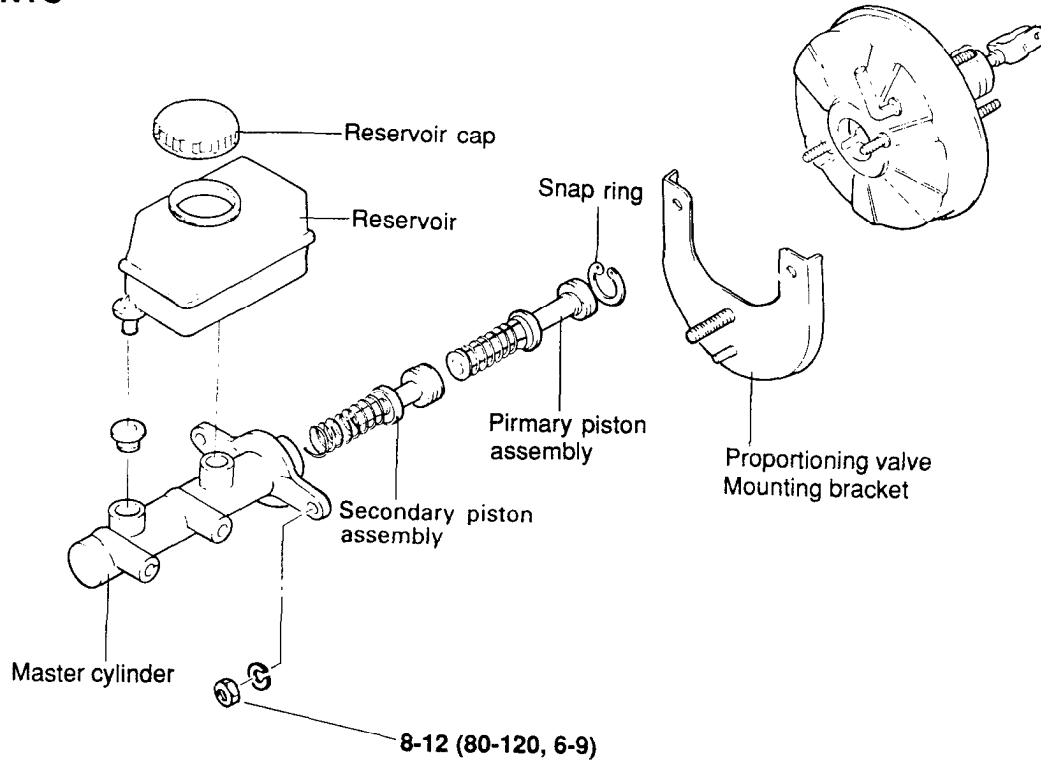

TORQUE : Nm (kg.cm, lb.ft)

REMOVAL

1. Remove the fluid level warning device connector.
2. Disconnect the brake lines from the master cylinder, and plug the open ports.

CAUTION

Do not allow brake fluid to remain on a painted surface. Wash it off immediately.

3. Remove the master cylinder mounting nuts. Disconnect the proportioning valve mounting bracket, then lift out the master cylinder.

DISASSEMBLY

1. Remove the reservoir cap and drain the brake fluid into a suitable container.
2. Remove the reservoir from the master cylinder.

NOTE

If necessary, support the master cylinder in a vise at its flange not at its bore.

3. While depressing the piston, remove the snap ring.

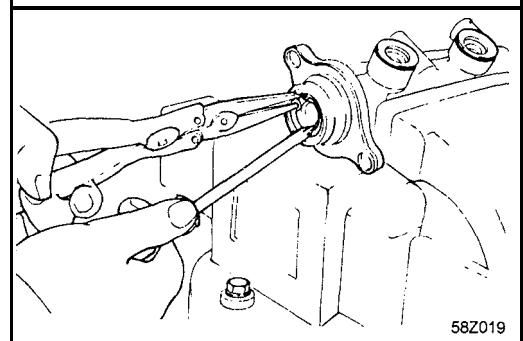
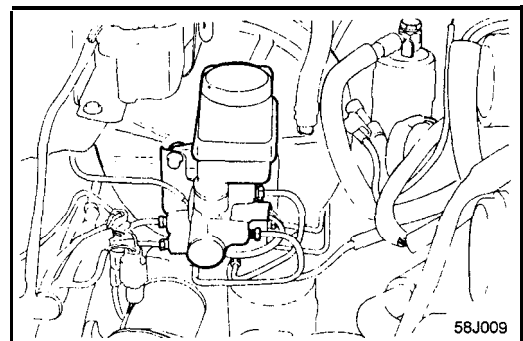

- Remove the primary and secondary pistons from the master cylinder body.

NOTE

- Be careful not to damage the cylinder bore.
- Do not disassemble the primary and secondary piston assemblies.

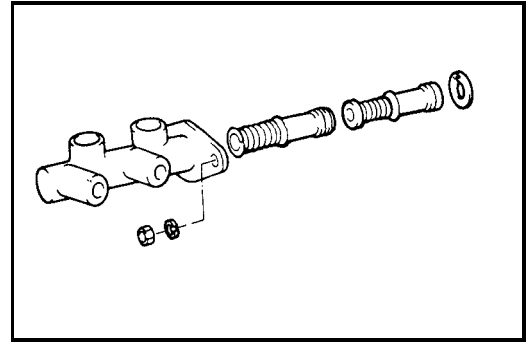
**INSPECTION**

- Check the master cylinder bore for rust or scoring.
- Check the primary and secondary pistons for rust, scoring, wear, damage or deterioration.
- Check the primary and secondary piston springs for deterioration.

ASSEMBLY

- Apply the specified brake fluid to the inner surface of the master cylinder body and to the outside of the secondary and primary pistons.

Recommended brake fluid DOT 3 or equivalent

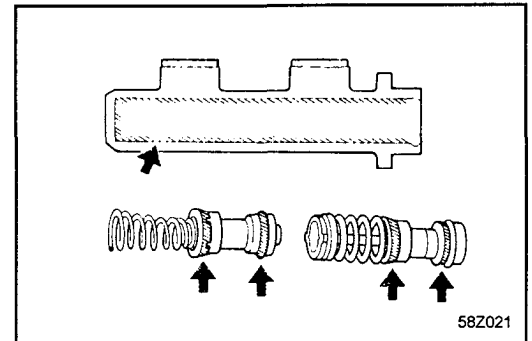

- Carefully insert the spring and secondary piston assembly in the master cylinder bore.
- Carefully insert the primary piston assembly in the master cylinder bore.
- Depress the primary piston and install the snap ring in the cylinder bore groove as illustrated.
- install the reservoir cap on the reservoir.
- Lubricate the two grommets at both inside and outside with genuine brake fluid and then insert them into the master cylinder body.

NOTE

Whenever the reservoir is replaced, the grommets must also be replaced.

- Press the reservoir into the master cylinder body with the fluid level indicator socket facing inboard. The reservoir should snap in place indicating that it is secure as illustrated.
- Connect the fluid level warning connector in the socket on the reservoir.

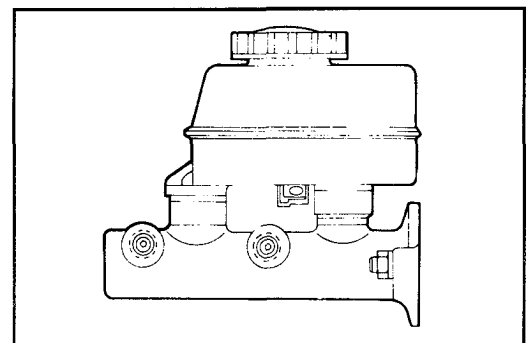
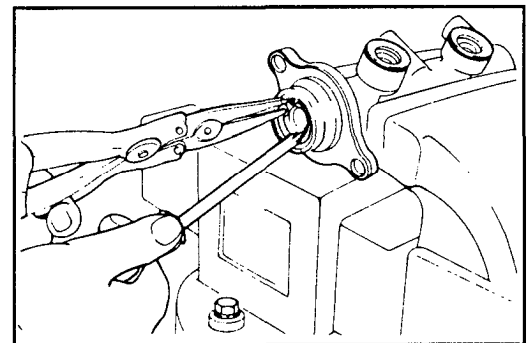

INSTALLATION

1. Install the master cylinder on the brake booster with two nuts.

Nut 8-12 Nm (80-120 kgcm, 6-9 lb.ft)

2. Connect two brake tubes and fluid level warning connector.

Brake tube flare in
13-17 Nm (130-170 kg.cm, 9-12 lb.ft)

3. Fill the master cylinder reservoir with brake fluid and bleed the system.

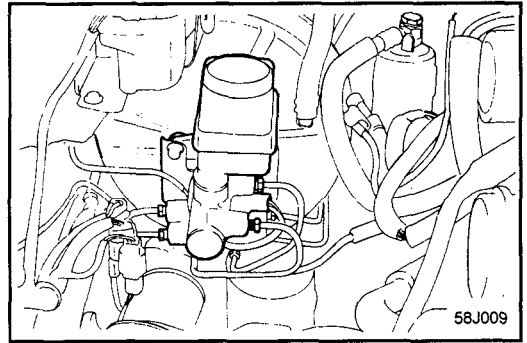

BRAKE BOOSTER

COMPONENTS

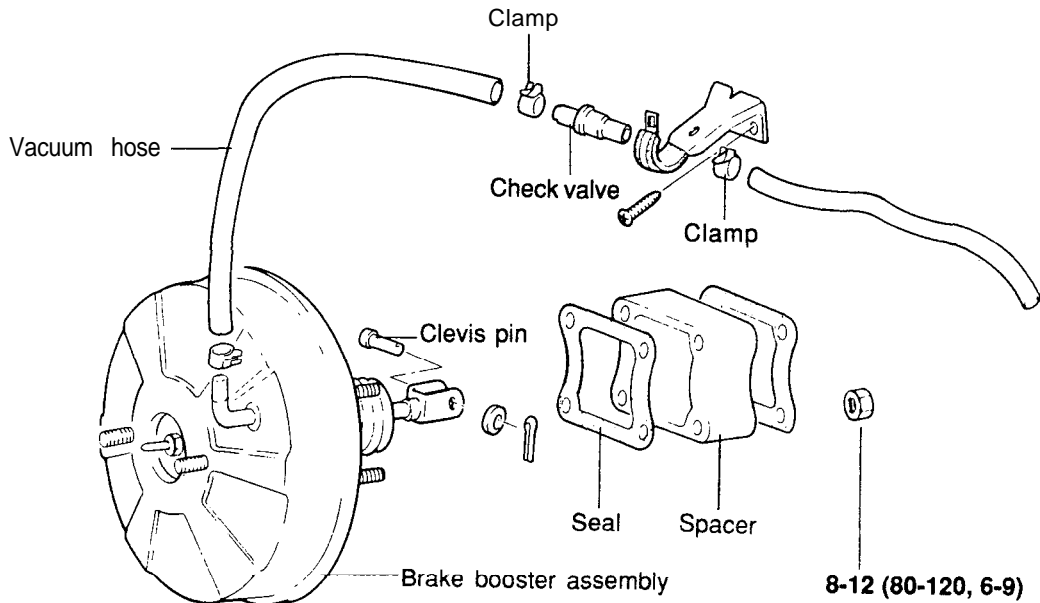

TORQUE : Nm (kg.cm, lb.ft)

CHECK VALVE OPERATION TEST

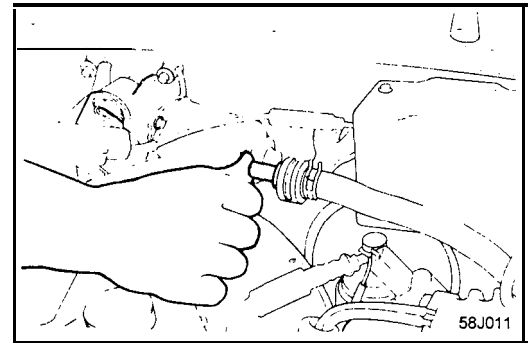
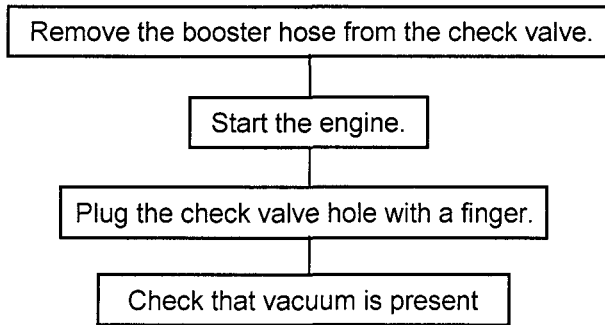

REMOVAL

1. Remove the master cylinder.
(Refer to page 58-13)

CAUTION

**Do not allow brake fluid to remain on a painted surface.
Wash it off immediately**

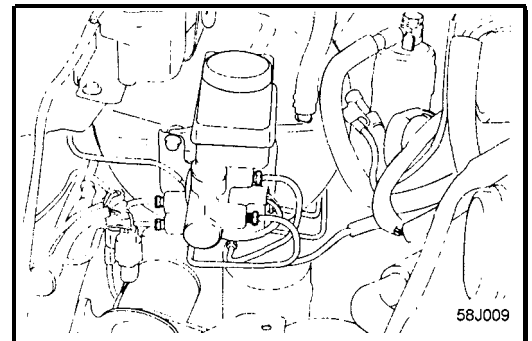

2. Disconnect the vacuum hose from the booster.
3. Remove the operating rod from the brake pedal.
4. Loosen the booster mounting nuts.
5. Lift out the booster assembly.

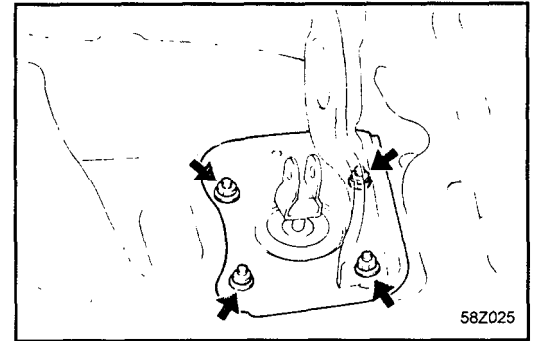

INSTALLATION

1. When the booster assembly is installed, replace the packing at each end of the booster mounting holder, if necessary.
2. Install brake booster and tighten the mounting nuts.

Tightening torque
 8-12 Nm (80-120 kg.cm, 6-9 lb.ft)

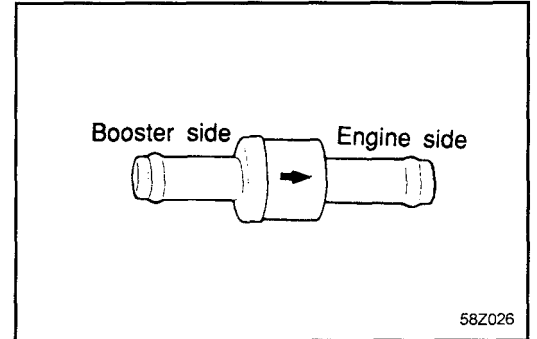

3. Connect clevis to brake pedal with clevis pin and install the split pin to the clevis pin.
4. Install master cylinder.
5. Connect vacuum hose to brake booster.
6. Pay attention to the direction of the check valve when installing.
7. Fill brake reservoir with brake fluid and bleed the system.
8. Check for fluid leakage.
9. Check and adjust the brake pedal (Refer to page 58-7).
10. After installation, apply sufficient grease to the clevis and brake pedal contacting points.

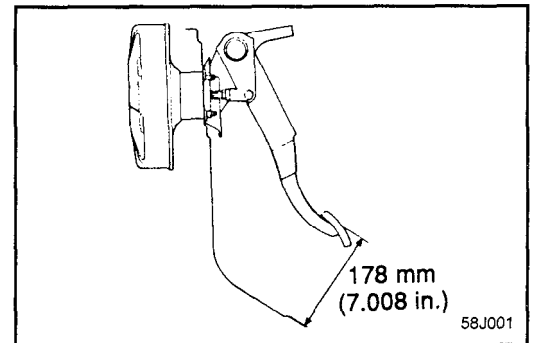

BRAKE LINE

COMPONENTS

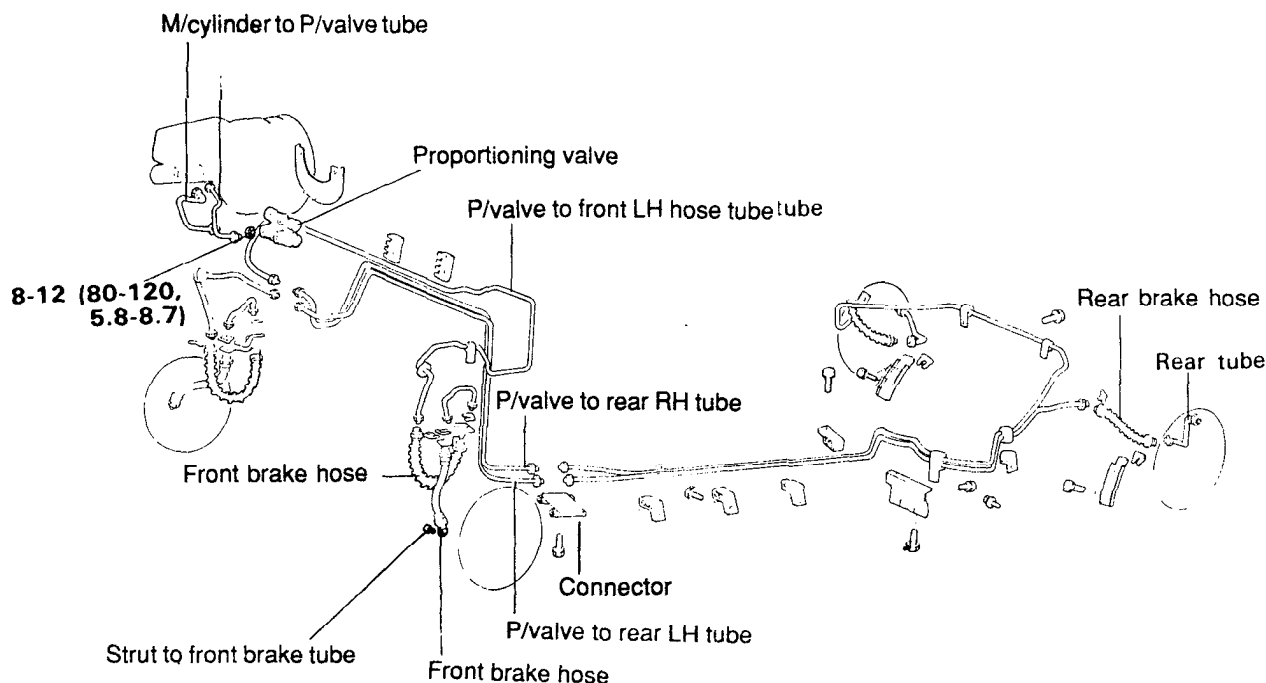

TORQUE : Nm (kg.cm, lb.ft)

INSPECTION

1. Check the brake lines for cracks, crimps and corrosion.
2. Check the brake hoses for cracks, damage and leakage.
3. Check the brake line flare nuts for damage and leakage.

INSTALLATION

1. Install the brake hoses without twisting them.
2. The brake lines should be installed away from sharp edges, weld beads or moving parts.
3. Tighten the connections to the specified torque.

Flare nuts	13-17Nm (130-170kg.cm,9-12lb.ft)
Brake hose to front caliper	25-30 Nm (250-300 kg.cm, 18-22 lb.ft)

PROPORTIONING VALVE

Do not disassemble the proportioning valve. The proportioning valve regulates the distribution of fluid pressure to the front and rear brakes to prevent skidding in the event of rear wheel lock, and to obtain greater braking efficiency.

PROPORTIONING VALVE FUNCTION TEST

1. Connect two pressure gauges, one the input side and one to the output side of the proportioning valve.

NOTE

Be sure to bleed the system after you connect the pressure gauges.

2. With the brakes applied, measure the input pressure and the output pressure. If the measured pressures are within the ranges as illustrated, the proportioning valve is good.
3. Reconnect the brake lines in their original positions and bleed the system.

NOTE

This figure shows characteristics of the proportioning valve during pressure increase.

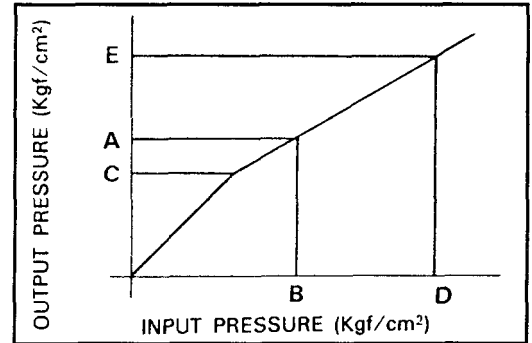

A	B	C	D	E
51 ± 3.5	80	40 ⁺⁶ ₋₂	140	67 ± 4

PROPORTIONING VALVE INSTALLATION

1. Install the brake lines according to the illustration.
2. Tighten the flare nuts and bleed the system.

Tightening torque

Brake tube flare nut	13-17 Nm (130-170 kg.cm, 9-12 lb.ft)
Proportioning valve mounting nut	8-12 Nm (80-120 kgcm, 6-9 lb.ft)

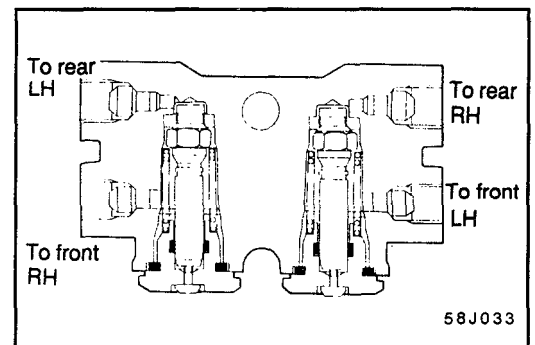

58J033

FRONT DISC BRAKE

COMPONENTS

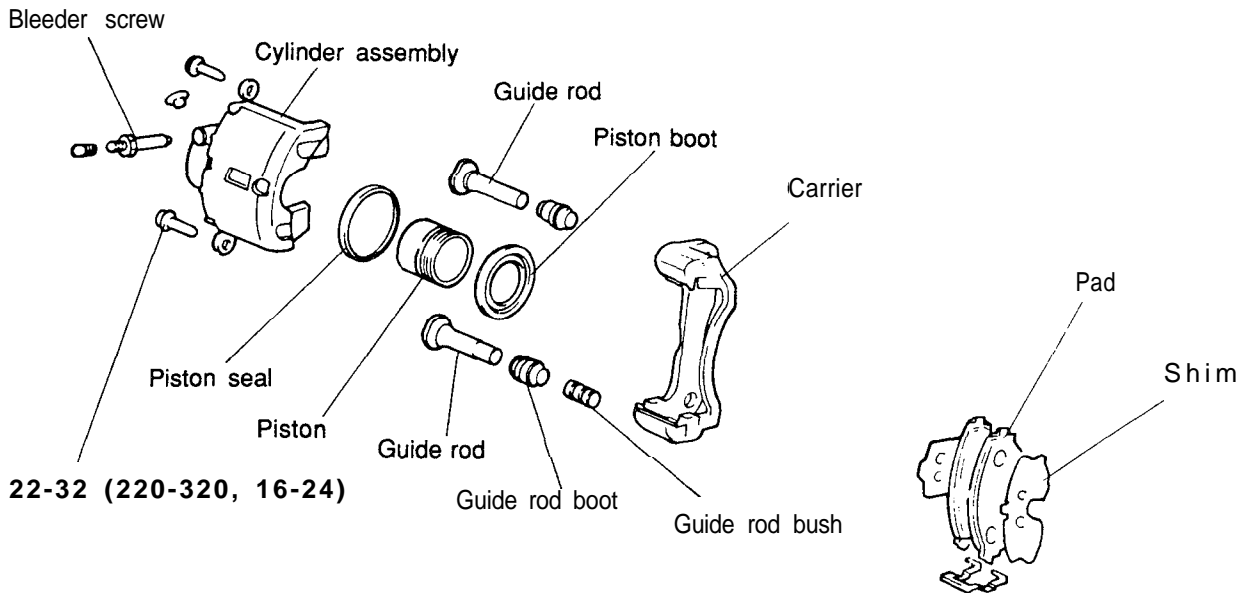

TORQUE : Nm (kg.cm, lb.ft)

REPLACEMENT OF BRAKE PADS

The brake pads have wear indicators that contact the brake disc when the brake pad thickness becomes 2 mm (0.08 in.). The wear indicators will generate a squealing sound to warn the driver.

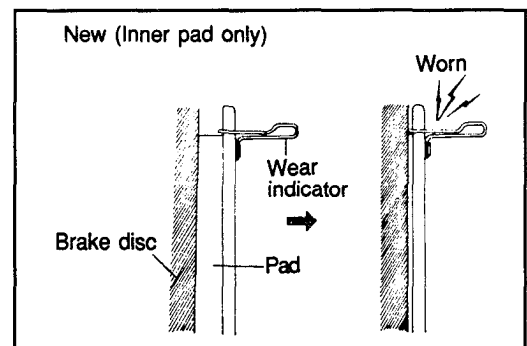

Removal

1. Remove the lower bolt and lift the caliper assembly up and out of the way. Secure it with wire or some other retaining method.
2. Remove the pads.

CAUTION

Do not depress the brake pedal while disassembling the pads.

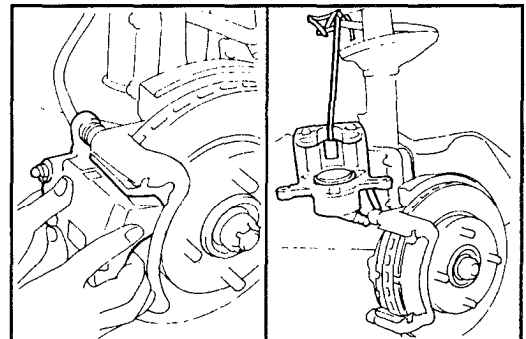

-Inspection

1. Check the pads for wear or oil contamination and replace, if necessary.

NOTE

The pads for the right and left wheels should be replaced at the same time. Never "split" or intermix brake pad sets. All four pads must be replaced as a complete set.

	Standard value	Service limit
Pad thickness mm (in.)	11(0.433)	2.0 (0.079)

2. Check the shims for damage or deformation.

Installation

1. Install the pad clips.
2. Install the pads onto each pad clip.

NOTE

Position the pad with its wear indicator toward the disc side and facing upward.

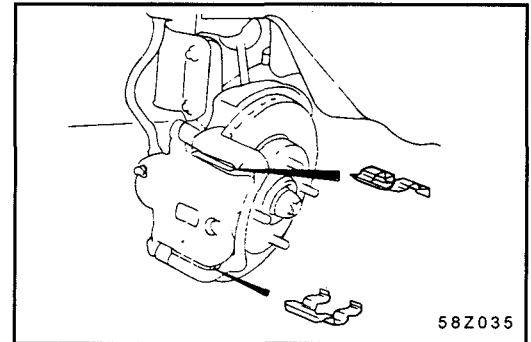

3. Seat the piston in the cylinder using special tool.

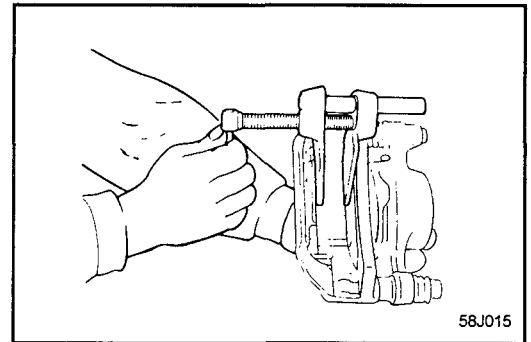

4. Install the new pads. The shims are attached to the each pad as illustrated.

NOTE

Never apply grease to the disc or pads.

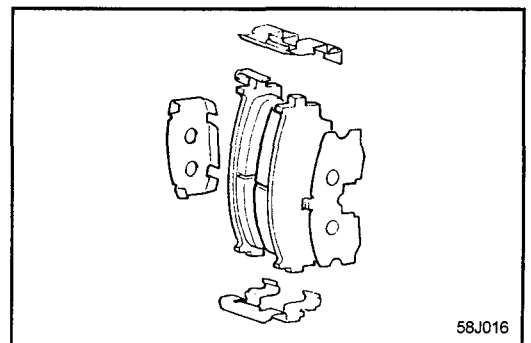

5. Install the bolt and tighten to the specified value.

Tightening torque
 22-32 Nm (220-320 kg.cm, 16-24 lb.ft)

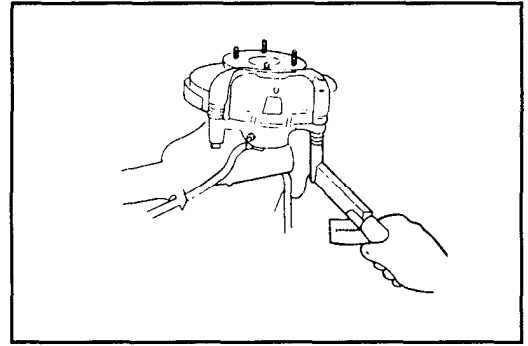

CALIPER ASSEMBLY

Removal

1. Remove the wheel and tire.
2. Disconnect the brake hose.
3. Remove the pads.
4. Remove the sleeve.
5. Remove the pin boot and sleeve boot.
6. Remove the caliper assembly.

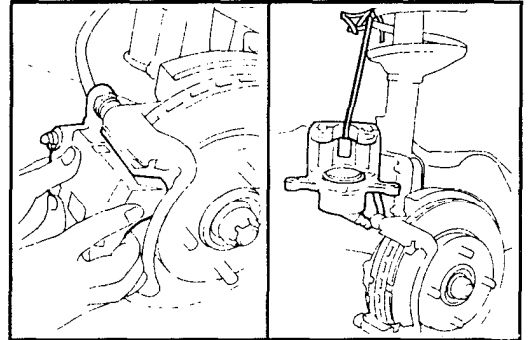

Disassembly

1. Remove the piston boot.
2. Remove the piston using compressed air.

CAUTION

- 1) Do not place fingers in front of the piston when using compressed air.
- 2) Be careful not to splatter the brake fluid.

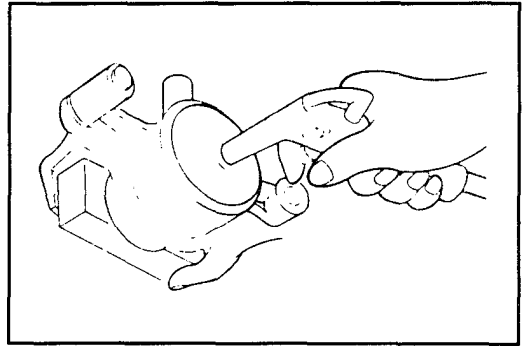

3. Remove the piston seal from the caliper using a screw driver.

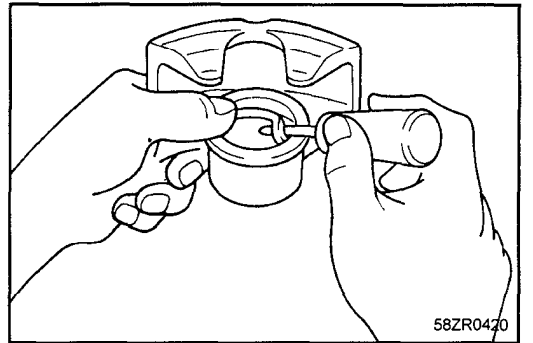

58ZR0420

Inspection

1. Check the caliper for wear, damage, cracks and rust.
2. Check the piston for rust, damage, cracks and wear on the outer surface.
3. Check the sleeve and pin for damage and rust.
4. Check the pad spring and boots for damage.
5. Check the carrier for damage, rust, wear and cracks.

NOTE

- 1) Do not use sand paper on the piston surface.
- 2) All rubber parts must be replaced with new ones.

6. Inspect the disc using a caliper and dial gauge.

		Standard value	Service limit
Thickness of disc mm (in.)	1.6, 1.8 DOHC	22 (0.876)	20 (0.787)
Total runout of front axle assembly mm (in.)			0.15 (0.006)

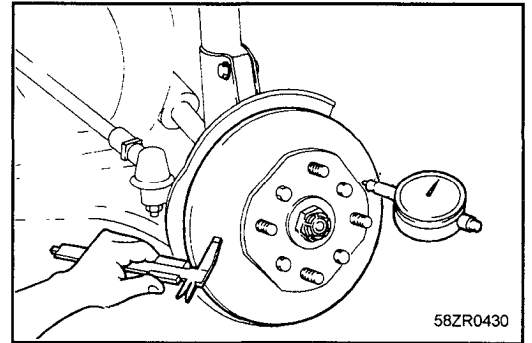

7. If necessary, replace the brake disc.
- 1) Remove the hub caps.
 - 2) Remove the drive shaft nut.
 - 3) Jack up the vehicle and support it with jack stands.
 - 4) Remove the wheel and tire.
 - 5) Remove the front wheel brake assembly from the knuckle and suspend it with a wire.
 - 6) Disconnect the lower arm ball joint from the knuckle using the Special Tool (09568-31000).

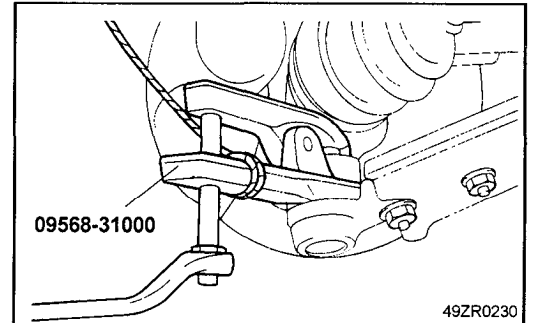

- 7) Disconnect the tie rod end ball joint from the knuckle using the Special Tool (09568-31000).

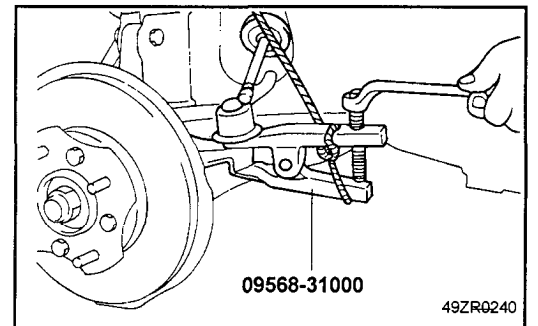

- 8) Disconnect the drive shaft from the hub using the special tool (09526-11001).

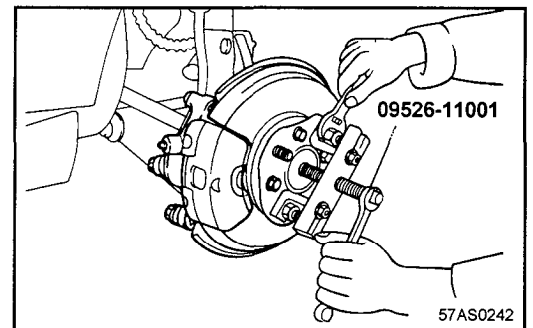

- 9) Remove the hub and knuckle as an assembly from the strut.

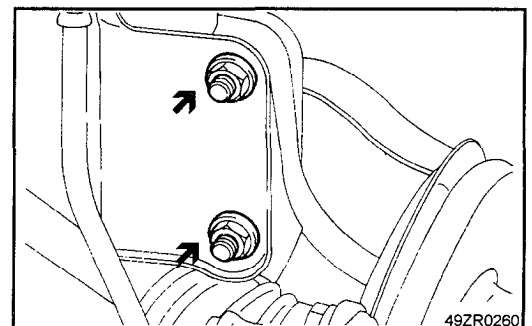

- 10) Remove the disc mounting bolts (4EA).
- 11) Install the special tools as illustrated.
- 12) Remove the hub from the knuckle by turning the special tool.

CAUTION

- 1) **Be sure to use the special tool.**
- 2) **If the hub and knuckle are disassembled by striking with a hammer, the bearing will be damaged.**

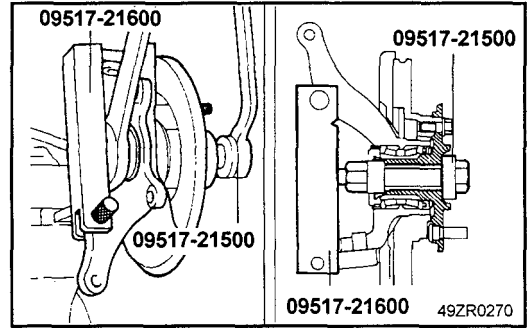

- 13) Replace the brake disc with new one.
- 14) Apply the specified multipurpose grease to the bearings and inside surface of the hub.
- 15) Remove inner oil seal.

- 16) Tighten the hub to the knuckle to 230 Nm (2,350 kg.cm, 167 lb.ft) with the Special Tool (09517-21500).
- 17) Rotate the hub to seat the bearing.

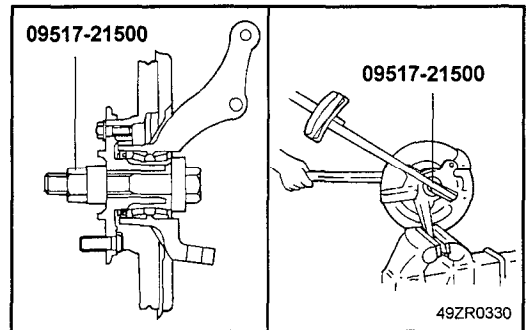

- 18) Measure the hub bearing starting torque.

Hub bearing starting torque [Limit]
 1.3 Nm (13kg.cm, 11 lb. in.) or less

- 19) If the starting torque is 0 Nm (0 in. lbs.), measure the hub bearing axial play.

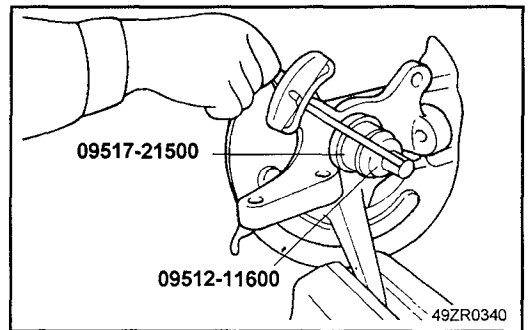

- 20) If the hub axial play exceeds the limit while the nut is tightened to 230 Nm (2,350 kg.cm, 167 lb. ft), the bearing, hub and knuckle have not been installed correctly. Repeat the disassembly and assembly procedure.

Hub bearing axial play [Limit]
 0.11 mm (0.0043 in.) or less

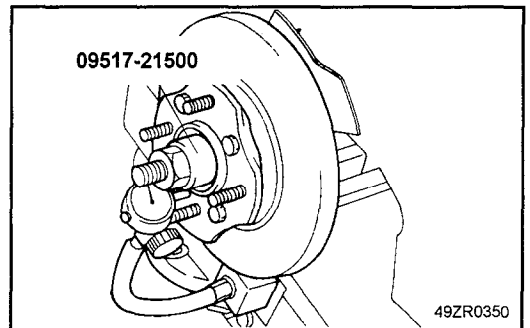

- 21) Remove the Special Tool.
- 22) Apply the specified multipurpose grease to the bearing and to the inside of the knuckle.

Recommended grease

Multipurpose grease SAE J310, NLGI No.2

- 23) Drive the oil seal (drive shaft side) into the knuckle until it contacts the bearing outer race using Special Tools.
- 24) Apply the specified multipurpose grease to the lip of the oil seal.
- 25) Install front wheel brake assembly, hub and knuckle to the specified torque.

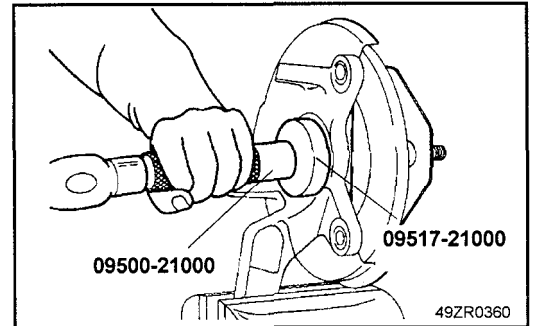

Assembly

1. Clean all components with isopropyl alcohol except the pads and shim.
2. Apply rubber grease to the piston seal and install the piston seal in the cylinder.

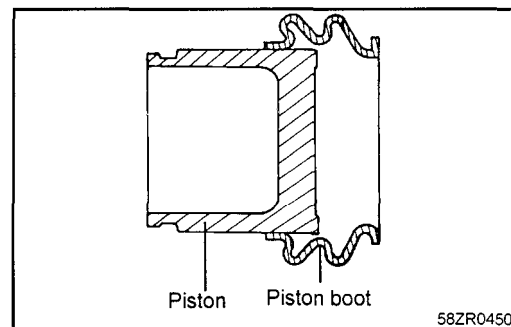

3. Assemble the piston and piston boots according to the following procedure.
 - 1) Apply rubber grease to the caliper bore, outside surface of the piston and piston boot.
 - 2) Install the piston boot on the piston as illustrated.
 - 3) Insert the piston boot in the inner groove of caliper and slide the piston into the caliper.

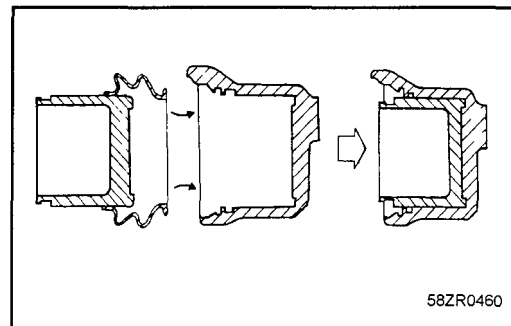

4. Assemble the sliding parts according to the following procedure.
 - 1) Apply rubber grease to the outside surface of the sleeve and pin, pin and sleeve bore of the caliper, pin boot and sleeve boot.
 - 2) Insert the boots into the groove of the caliper.

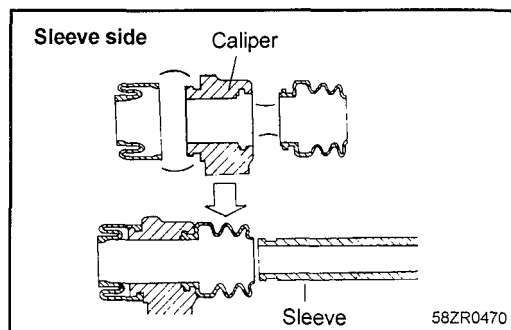

5. Install the pads.

NOTE

Do not apply grease to the disc or pads.

6. Tighten the brake hose connecting bolt.

Tightening torque	Nm (kg.cm, lb.ft)
Sliding pin	35-45 (350-450, 26-33)
Sliding bolt	22-32 (220-320, 16-24)
Carrier mounting bolt [1.51	65-75 (650-750, 48-55)
[1.6, 1.8]	69-85 (690-850, 44-63)
Brake hose mounting oil bolt	25-30 (250-300, 18-22)

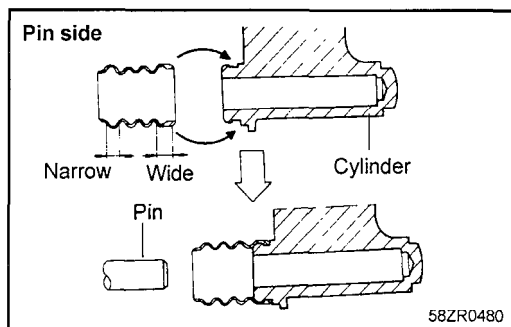

NOTE

- 1) Check that the surfaces of the pin and bolts are not damaged before tightening.
- 2) Bleed the system.
Depress the pedal several times and check for fluid leakage from all connecting parts.

REAR DRUM BRAKE

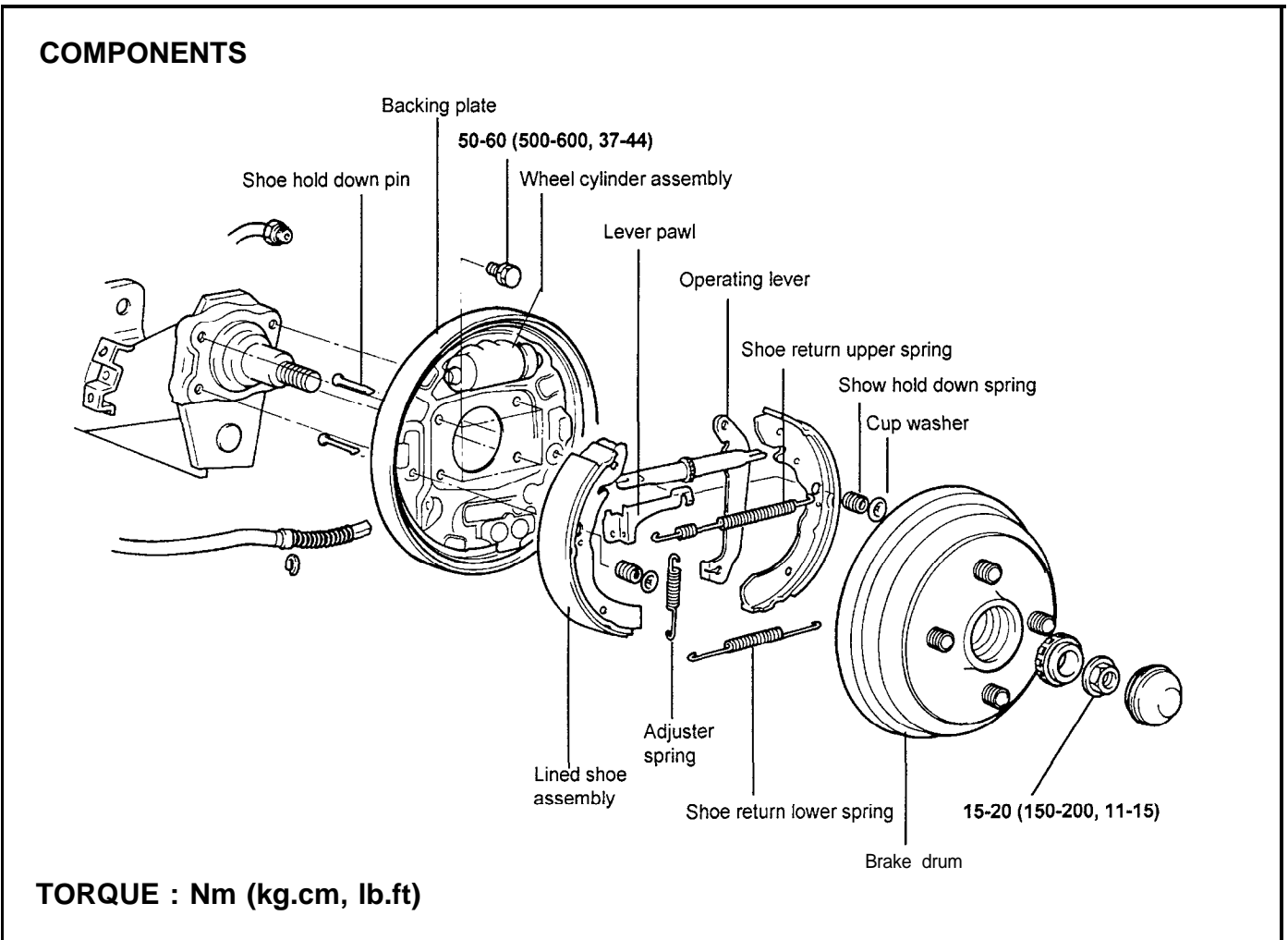

REMOVAL

1. Removing the wheel and tire, then remove brake drum.
2. After removing the rear wheel bearing nut, remove the rear hub with the brake drum.
3. Remove the shoe return lower spring, shoe hold down spring
4. Remove the shoes and adjuster as an assembly.

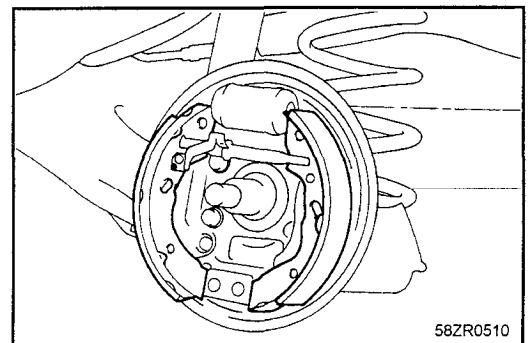
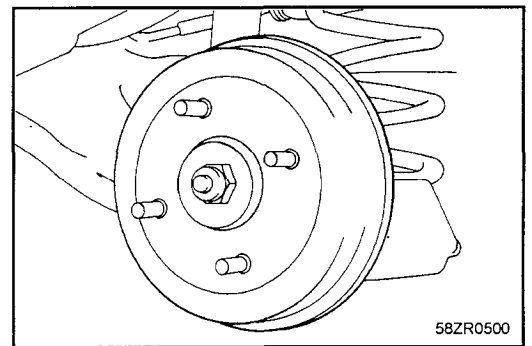

INSPECTION

1. Measure the brake drum inside diameter.
Check the runout of the brake drum using a dial indicator.
mm (in.)

	Standard value	Service limit
Inside diameter	203.2 (8)	205.2 (8.079)
Out-of-rounded of brake drum		0.015 (0.0006)

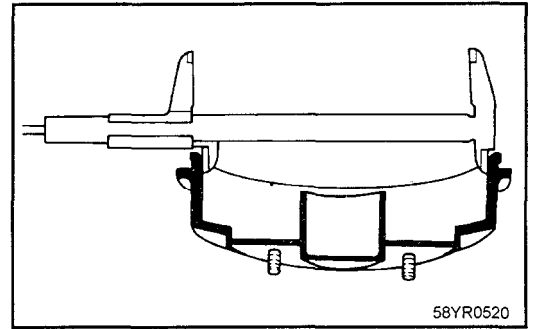

2. Measure the brake shoe lining thickness.

	Standard value	Service limit
Lining thickness mm (in.)	4.05 mm (0.159 in.)	1.5 (0.059)

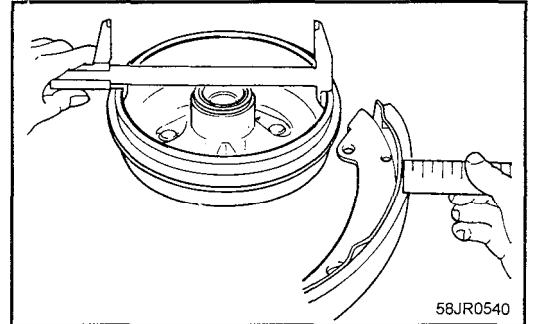

3. Inspect the brake lining and drum for proper contact.
4. Inspect the wheel cylinder outside for excessive corrosion and damage.
5. Inspect the backing plate for wear or damage.

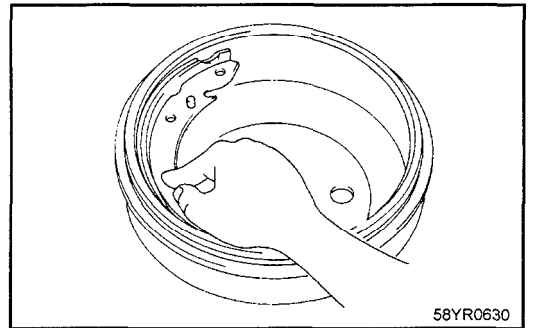

INSTALLATION

1. Apply a specified grease to the locations indicated in the illustration and to each component.
 - o Shoe and backing plate contact surfaces
 - o Shoe and anchor plate contact surfaces

Recommended grease
Multipurpose grease SAE J310, NLGI No.2

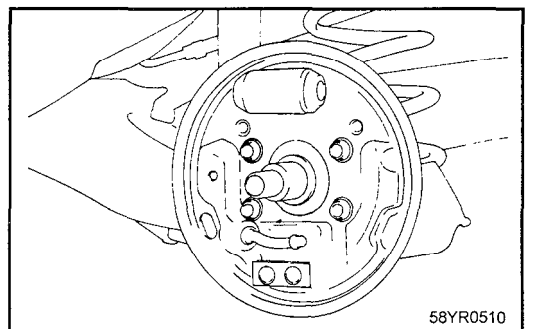

2. Install the shoe hold down pin.

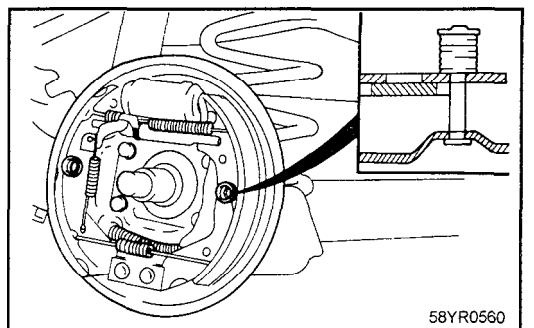

3. Assemble the return spring with the push rod shortened.
4. After assembling the drum components, pull the parking brake lever all the way up several times.

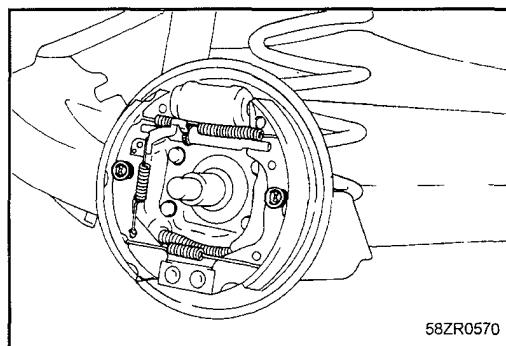

WHEEL CYLINDER REPLACEMENT

1. Remove the brake shoe.
2. Disconnect the brake tube.
3. Remove the wheel cylinder assembly.

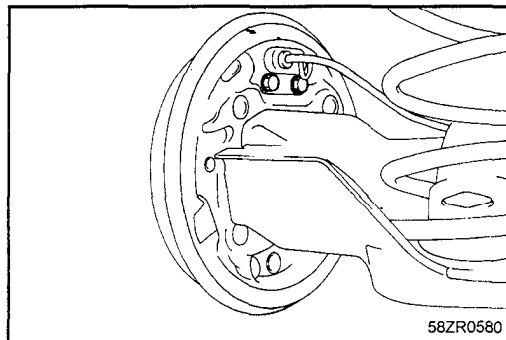

4. Remove the dust boot.
5. Remove the piston and piston cup.
6. Drive out the return spring.

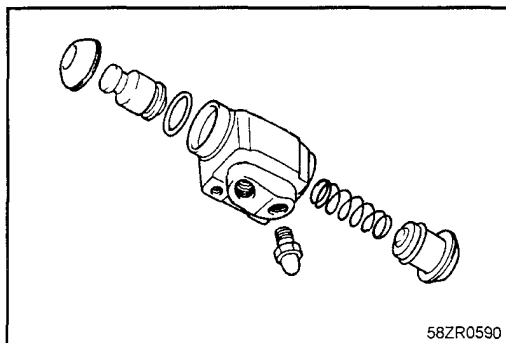

7. Before assembling the wheel cylinder, inspect the following points.
 - 1) Check the cylinder and piston for wear, damage and rust.
 - 2) Check the cylinder body for damage and cracks.
 - 3) Check the contact surface of the piston and shoes for wear.
 - 4) Check the piston spring for looseness.
8. Assembly is the reverse of the removal procedure.

NOTE

- 1) Clean the cylinder and inner part with isopropyl alcohol before assembly.
- 2) Apply enough brake fluid to piston cups and cylinder.
- 3) Be sure to use new piston cups and dust boots.

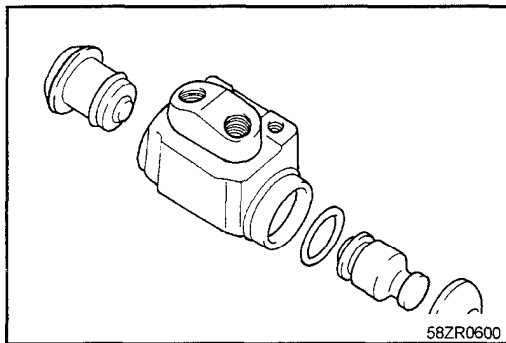

NOTE

Be careful not to lose the steel ball in the bleeder.

REAR DISC BRAKE

COMPONENTS

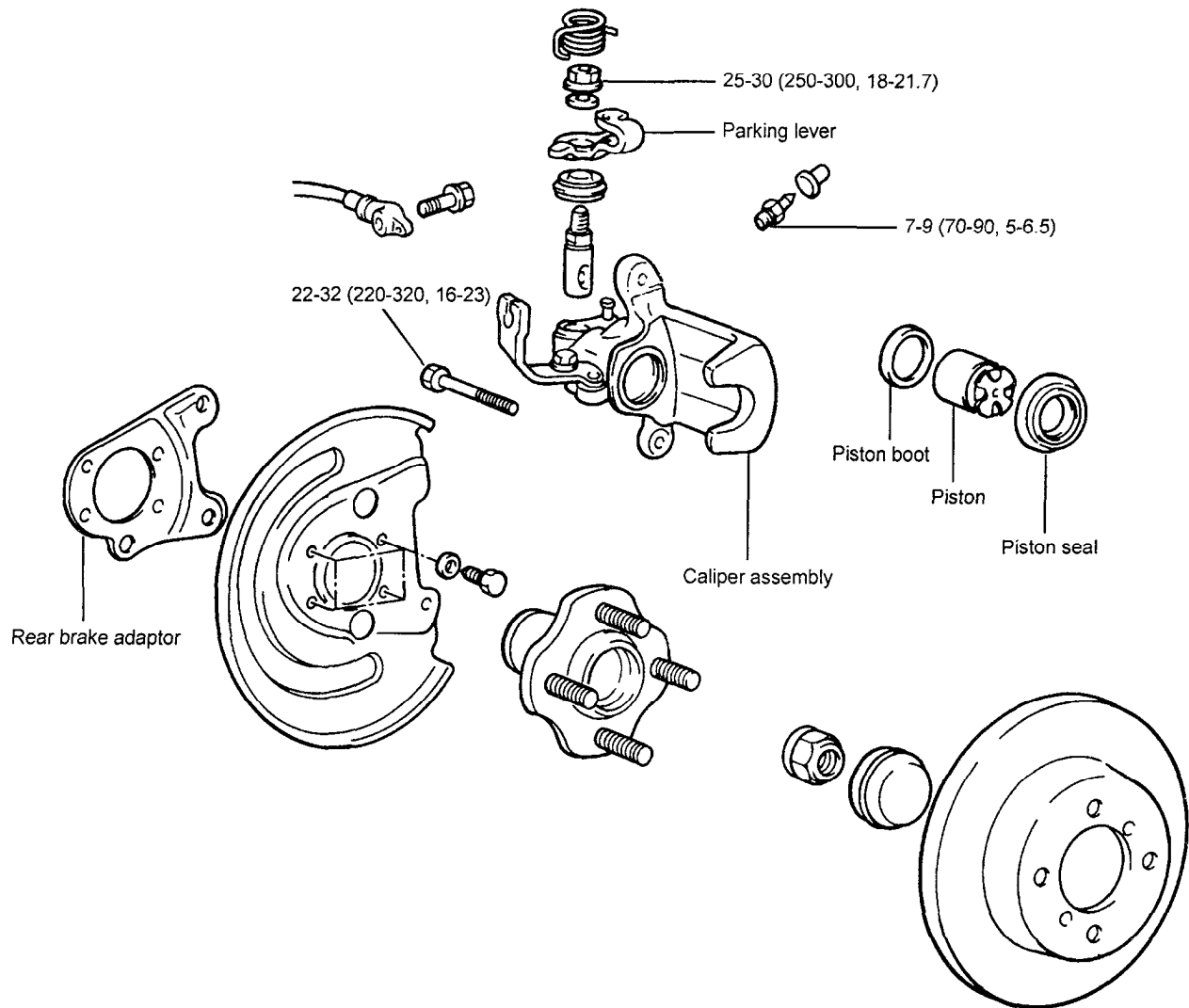

TORQUE : Nm (kg.cm, lb.ft)

DISC BRAKE PAD

REMOVAL

1. Remove the wheel
2. Remove the screw which holds the trailing shoe key onto the anchor plate.
3. Release the parking cable adjusting nut.
4. Remove the parking cable.

5. Remove the brake fluid hose.
6. Remove the caliper assembly

NOTE

Support the caliper with a wire or some other means to prevent damage to the brake hose.

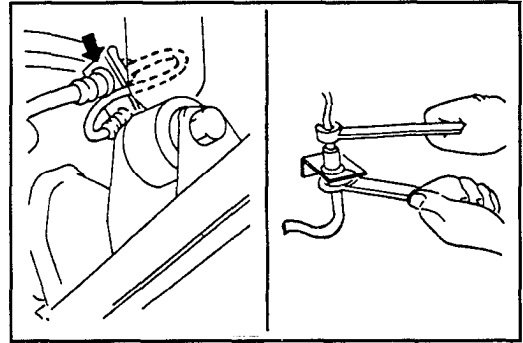

7. Remove the ABS wheel speed sensor.

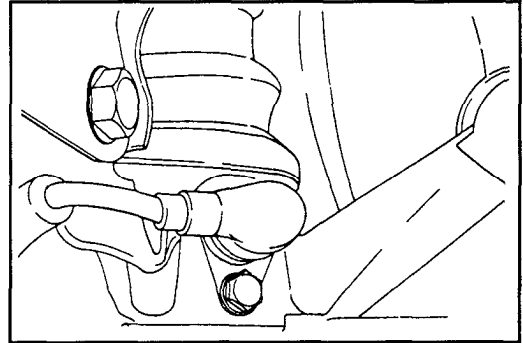

8. Remove the wheel bearing nut
9. Remove the wheel hub and dust cover.

INSPECTION

1. Check the pads for wear or oil contamination and replace if necessary.

NOTE

The pads for the right and left wheels should be replaced at the same time

Pad thickness wear limit 0.8 mm

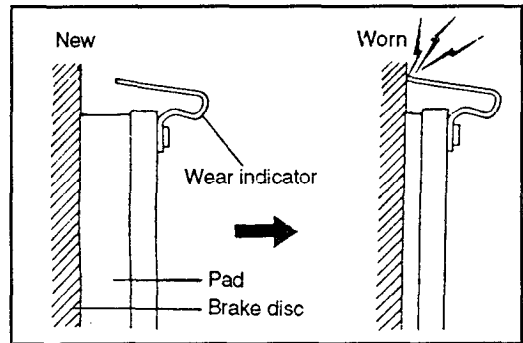

2. Check the leading and trailing shoe keys and retaining screw for damage, or wear. Replace the keys and retaining screw at the same time the pads are replaced.
3. Check for worn or damaged dust boots if dust or mud has entered the caliper assembly through this seal, the caliper assembly must be replaced or rebuilt.

INSTALLATION

1. Before replacing the brake pads, remove brake fluid from the master cylinder reservoir until it is half full.

CALIPER

Disassembly

1. Remove the caliper mounting bolts, and remove the caliper assy.
2. Remove the carrier bolt, and remove the carrier with brake pad.
3. Remove the piston boot.
4. Remove the piston assy with special tool to twist the piston out of the caliper body.
5. Remove piston seal with finger tip.

CAUTION

Do not use sharpened tools to prevent damage to inner cylinder.

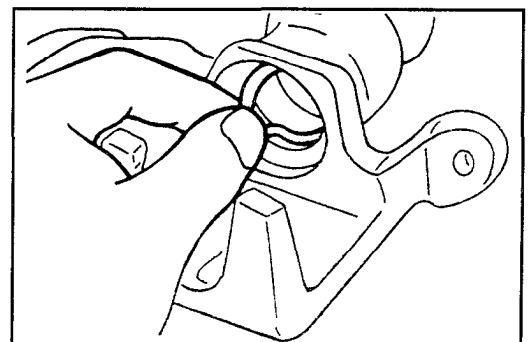
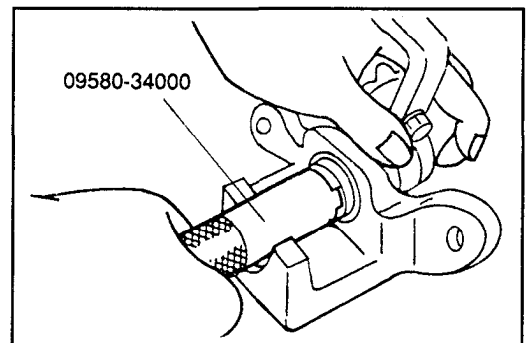
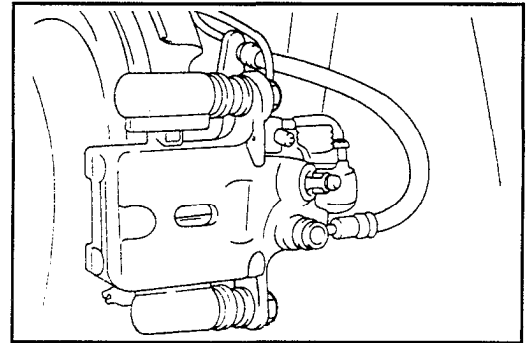
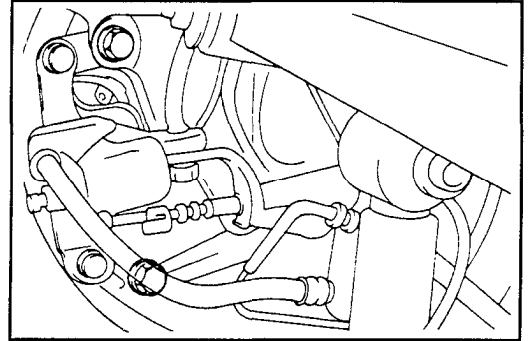

Assembly

1. Check for worn, damaged, or rusted piston bore and piston. Replace the damaged parts if necessary.
2. Check for damaged piston seal, boot, and pin insulators.

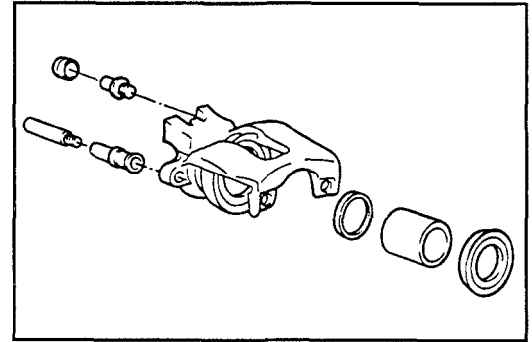

3. Apply a recommended lubricant to the following parts

Parts	Recommended lubricant	Quantity
Piston seal	Brake fluid (Dot 3)	As required
Cylinder inner side	Brake fluid (Dot 3)	As required
Piston boot	Brake fluid (Dot 3)	As required
Piston outer surface	Brake fluid (Dot 3)	As required
Guide-rod insulators	Rubber grease	As required

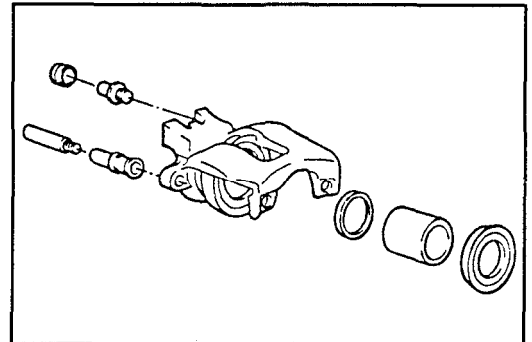

4. Push the piston into the caliper with special tool.

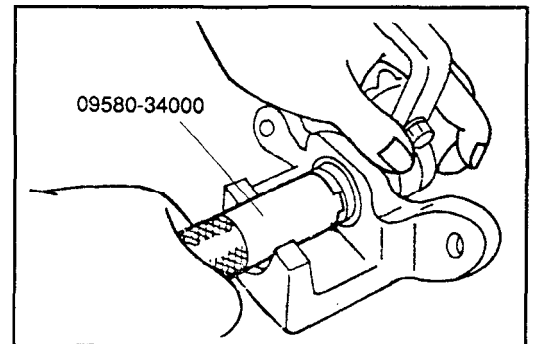

PARKING BRAKE

COMPONENTS

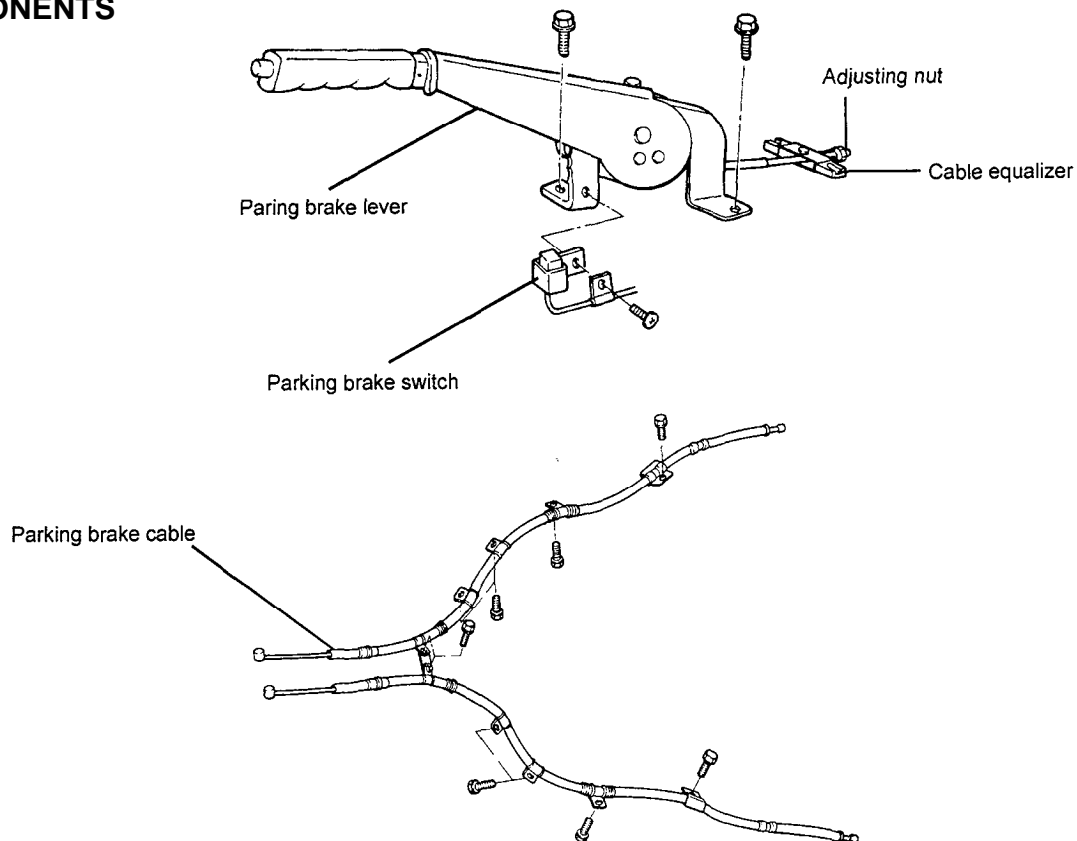

TORQUE : Nm (kg.cm, lb.ft)

REMOVAL

1. Remove the rear console.
2. Loosen the adjusting nut and detach the parking brake cable.
3. Detach the parking brake switch assembly.
4. Remove the parking brake lever assembly.

5. Remove the wheel and tire.
6. Remove the brake drum.
7. Remove the brake shoes as outlined before.
8. Detach the parking brake cable from the brake shoe.

9. Remove the parking brake cable retaining ring in the rear of the backing plate.

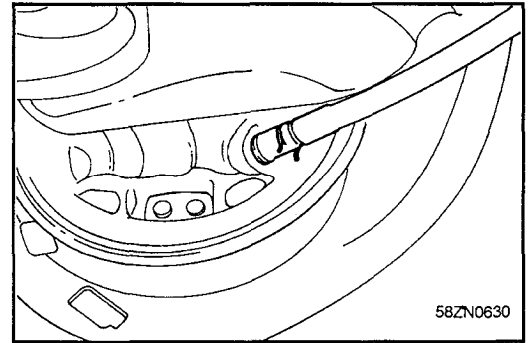

10. Remove the rear seat cushion assembly and roll up the carpet.
11. Loosen the parking brake cable clamp and remove the parking brake cable assembly.

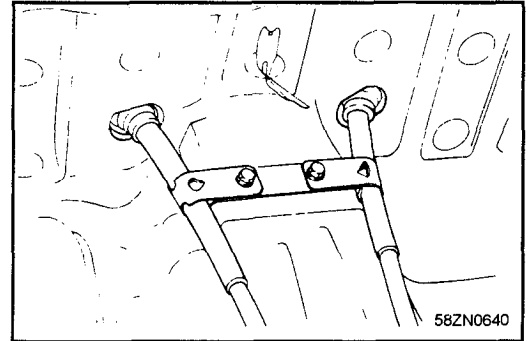

INSPECTION

1. Check the parking brake switch operation.
2. Check the parking brake lever ratchet for wear.
3. Check the parking brake cable for fraying or damage.

INSTALLATION

1. Check the parking brake cables for left and right identification marks and install accordingly.

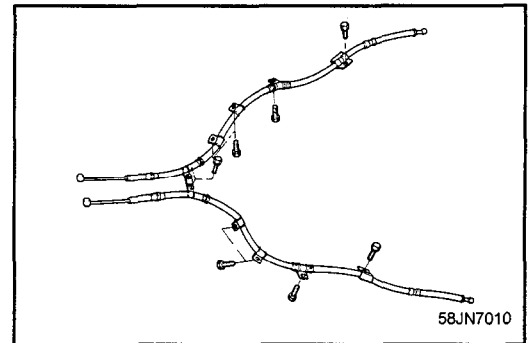

2. Move the adjuster lever all the way back when installing the shoe-to-shoe spring.

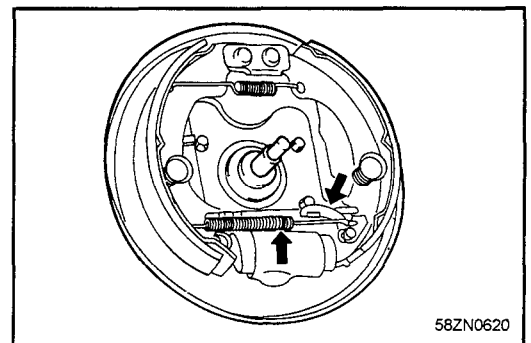

3. Install the grommets in the direction shown in the illustration.

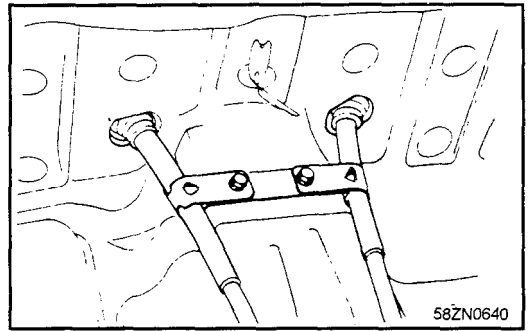

4. Apply a coating of the specified grease to the sliding parts of the ratchet plate and ratchet pawl.

Specified grease
 Multipurpose grease SAE J310, NLGI No. 2

5. After installing the cable adjuster, adjust the parking brake lever stroke.

