

FRONT SUSPENSION

Return To Main Table of Contents

GENERAL	2
STRUT ASSEMBLY	11
LOWER ARM	13
STABILIZER BAR	17
CENTER MEMBER	19
WHEEL AND TIRE	21

GENERAL**SPECIFICATIONS**

Suspension system	Macpherson strut with coil spring
-------------------	-----------------------------------

Coil spring

Free height and identification color

Model	Free height mm (in.)	identification color
1.6 GL - NC	365.4 (14.38)	Green 3 lines
1.6 GL + NC 1.8 GLS - A/C 1.8 GL ALL	372.8 (14.67)	Red 3 lines
1.8 GLS + A/C	382.7 (15.06)	Yellow 3 lines

GL, GLS : Trim level A/C : Air conditioning

Shock absorber

Type

Hydraulic cylindrical double-acting type

Maximum length

478 mm (18.8 in.)

Compressed length

320 mm (12.6 in.)

Stroke

158 mm (6.2 in.)

Stabilizer bar

Length (center to center)

1000 mm (39.4 in.)

O.D.

20 mm (0.8 in.)

Wheel and Tire

Tire size

P 175/70 HR 14

P 185/60 HR 14

T 125/70 D 15

Temporary tire

Tire inflation pressure

kPa (psi)

200 (29)

Temporary tire

414 (60)

Wheel size

5.5 JJ x 14 (Steel wheel)

5.5 JJ x 14 (Al, wheel)

4T x 15 (Temporary tire)

SERVICE STANDARD

Standard value			
Toe		3 mm in - 3 mm out	
Camber		0° ± 30'	
Caster		2° 34' ± 30'	
King pin inclination angle		13° 3'	
King pin offset		-2.6 mm	
Wheel runout		[Steel wheel]	[Aluminum wheel]
Radial	mm (in.)	0.7 (0.028) : Average of LH & RH	
Axial	mm (in.)	1.0 (0.039)	
			0.3 (0.012)
			0.3 (0.012)





TIGHTENING TORQUE

	Nm	kg.cm	lb.ft
Strut upper installation nut	40-50	400-500	29-36
Strut assembly to knuckle	110-130	1100-1300	80-94
Strut mounting self locking nut	60-70	600-700	43-51
Lower arm ball joint to knuckle	60-72	600-720	43-52
Lower arm front mounting nut	95-120	950-1200	69-87
Lower arm rear mounting bolt	60-80	600-800	43-58
Stabilizer link to lower arm mounting nut	35-45	350-450	25-33
Stabilizer bar lower/upper bracket mounting bolt	17-26	170-260	12-19
Tie rod end ball joint to knuckle	15-34	150-340	11-25

LUBRICANTS

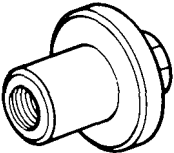
Front wheel bearing	SAE J310a Multi-purpose grease NLGI-2 or equivalent	As required
In ball joint of lower arm	Valiant R-2 grease or poly lub gly 801 K	As required
In insulator bearing of strut	SAE J310a, Chassis grease (NLGI No.0 or equivalent)	As required
Inside surface and lip of ball joint dust cover	Sunlight MB-2	As required

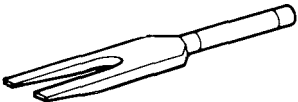
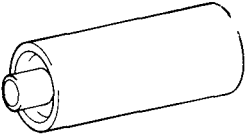
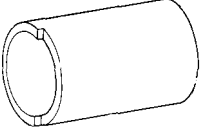
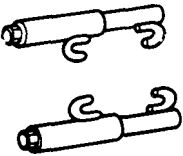
SPECIAL TOOLS

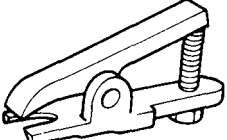
Tool (Number and Name)	Illustration	Use
09529-21000 Wheel alignment gauge attachment		Front wheel alignment for aluminum type wheel.
09532-11600 Pre-load socket		Measurement of the front lower arm ball joint starting torque. (use with torque wrench)
09545-21000 Ball joint remover		Removal of the front lower arm ball joint
09545-28100 Lower arm bushing arbor		Removal and installation of the front lower arm bushing. (use with 09545-28000)
09545-28000 Lower arm bushing remover and installer, base		Removal & installation of the front lower arm bushing. (use with 09545-28100)
09546-11000 (J38402) Spring compressor		Compression of the front coil spring.
09546-21000 Special spanner		1) Removal & installation of the front coil spring. 2) Removal & installation of the shock absorber oil seal.
09568-31000 Tie rod end puller		Separation of the tie rod end ball joint.

TROUBLESHOOTING

Symptom	Probable cause	Remedy
Hard steering	Improper front wheel alignment Excessive turning resistance of lower arm ball joint Low tire pressure No power assist	Correct Replace Adjust Repair and replace
Poor return of steering wheel to center	Improper front wheel alignment	Correct
Poor or rough ride	Improper front wheel alignment Malfunctioning shock absorber Broken or worn stabilizer Broken or worn coil spring Worn lower arm bushing	Correct Repair or replace Replace Replace Replace the lower arm assembly
Abnormal tire wear	Improper front wheel alignment Improper tire pressure Malfunctioning shock absorber	Correct Adjust Replace
Wandering	Improper front wheel alignment Poor turning resistance of lower arm ball joint Loose or worn lower arm bushing	Correct Repair Retighten or replace
Vehicle pulls to one side	Improper front wheel alignment Excessive turning resistance of lower arm ball joint Broken or worn coil spring Bent lower arm	Correct Replace Replace Repair
Steering wheel shimmy	Improper front wheel alignment Poor turning resistance of lower arm ball joint Broken or worn stabilizer Worn lower arm bushing Malfunctioning shock absorber Broken or worn coil spring	Correct Replace Replace Replace Replace Replace
Bottoming	Broken or worn coil spring Malfunctioning shock absorber	Replace Replace

WHEEL AND TIRE DIAGNOSIS

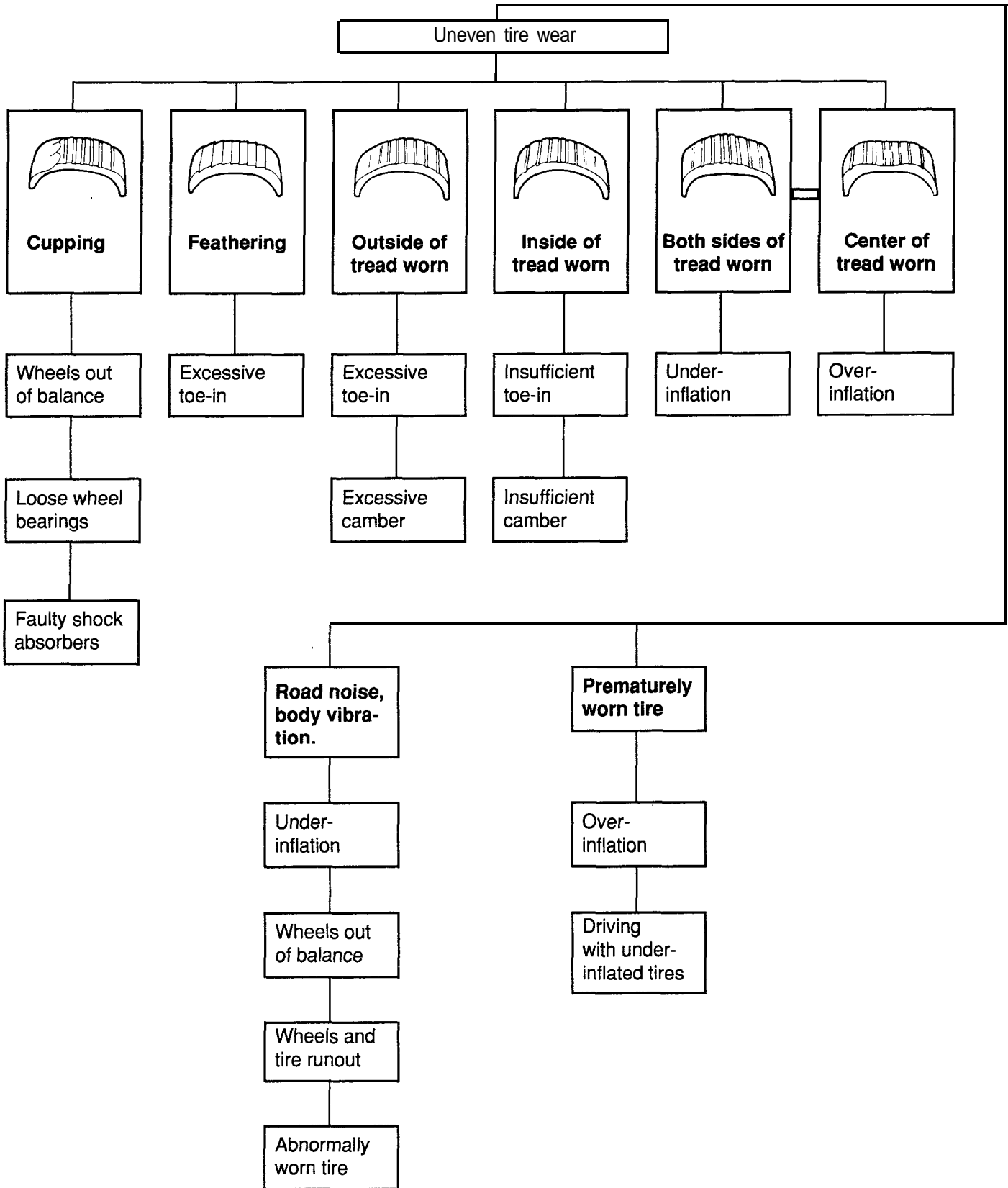

**SERVICE ADJUSTMENT PROCEDURES
FRONT WHEEL ALIGNMENT**

When using a wheel alignment tester to inspect front wheel alignment, always position the car on a level surface and the front wheels in the straight ahead position. Prior to inspection make sure that the front suspension and steering system are in normal operating condition and that wheels and tires are free of deflection and tires are inflated to specification.

Toe-in

Toe-in (B-A or angle e) is adjusted by turning the tie rod turn-buckles. Toe in on the left front wheel can be reduced by turning the tie rod toward the rear of the car. Toe change is achieved by turning the tie for the right and left wheels simultaneously the same amount as follows:

Description		Toe changes mm (in.)/deg.
No. of turns of tie rod (Same amount for right and left)	1/2	Approx. 5.5 (0.217)/32.5'
	1	Approx. 11 (0.433)/1°5'

NOTE

- 1) Toe-in adjustment should be made by turning the right and left tie rods the same amount.
- 2) When adjusting toe-in, loosen the outer bellows clip to prevent twisting the bellows.
- 3) After the adjustment, firmly tighten the tie rod end lock nuts and reinstall the bellows clip.

Toe (B-A) mm (in.) [Standard value]
3 in-3 out (0.12 in-0.12 out)

Tie rod end lock nuts tightening torque
34-50 Nm (340-500 kg.cm, 25-36 lb.ft)

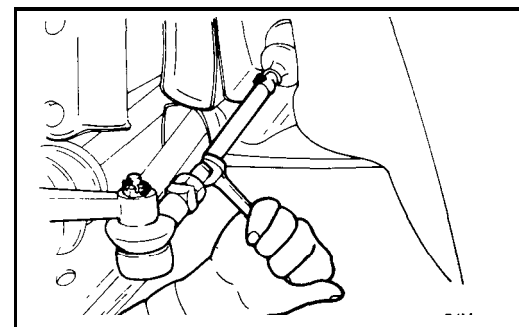
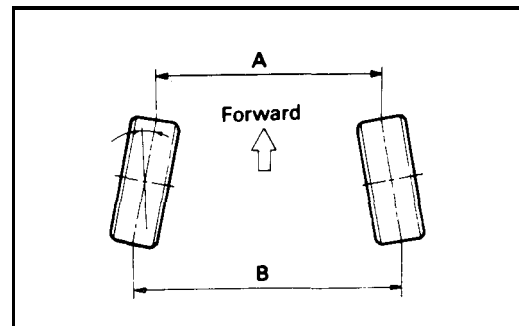

Camber

The steering knuckle which is integral with the strut assembly is pre-adjusted to the specified camber at the factory and requires no adjustment.

Camber [Standard value] $0^{\circ} \pm 30$

Caster

Caster is pre-set at the factory and can not be adjusted. If caster is not within standard value, replace the bent or damaged parts.

Caster [Standard value]	$2^{\circ}34' \pm 30'$
-------------------------	-------	------------------------

NOTE

- 1) The front suspension assembly must be free of worn, loose or damaged parts prior to measuring front wheel alignment.
- 2) Measure wheel alignment by using the special tool.
- 3) Camber and caster are pre-set at the factory and cannot be adjusted.
- 4) If camber and caster are not within specifications, replace bent or damaged parts.

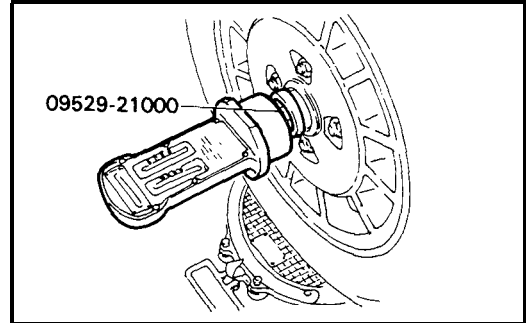
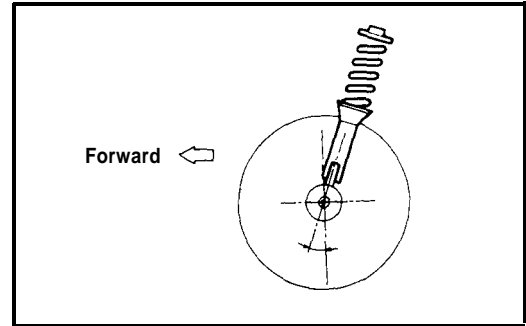

Steering Angle

Steering angle, as a rule, requires no adjustment. However, if there is a difference in steering angle between the right and left wheels, change the length of the right and left tie rods.

Steering angle [Standard value]		
Inner wheel θ_1	$39^{\circ}25' \pm 1^{\circ}30'$
Outer wheel θ_2	$33^{\circ}59'$

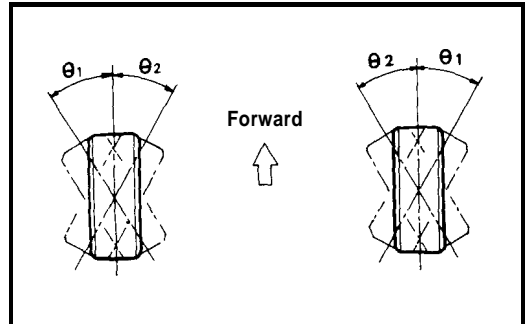

TIRE WEAR

1. Measure the tread depth of the tires.

Tread depth of tire [Limit]	1.6 mm (0.06 in.)
-----------------------------	-------	-------------------

2. If the remaining tread depth is less than the limit, replace the tire.

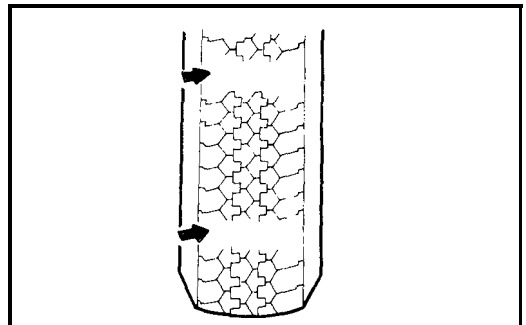

NOTE

When the tread depth of the tires is reduced to 1.6 mm (0.06 in.) or less, the wear indicators will appear.

WHEEL RUNOUT

1. Jack up the vehicle and support it with jack stands.
2. Measure wheel runout with a dial indicator as illustrated.
3. Replace the wheel if wheel runout exceeds the limit.

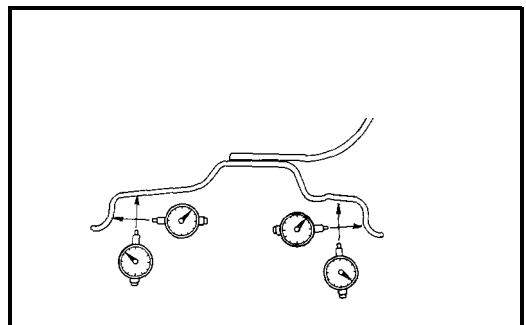

Wheel runout [Limit]		
Steel wheel		Radial 0.7 mm (0.028 in.) :(Average of LH & RH) Axial 1.0 mm (0.039 in.)
Aluminum type wheel		Radial 0.3 mm (0.012 in.) Axial 0.3 mm (0.012 in.)

WHEEL NUT TIGHTENING

1. Tightening torque

Steel and aluminum alloy wheel

Specified torque
90-110 Nm (900-1,100 kg.cm, 65-80 lb.ft)

CAUTION

When using impact-wrench, final tightening torque should be checked using a hand torque wrench.

2. Tightening order

Go around the wheel tightening every other nut until they are all tight.

Then double-check each nut for tightness.

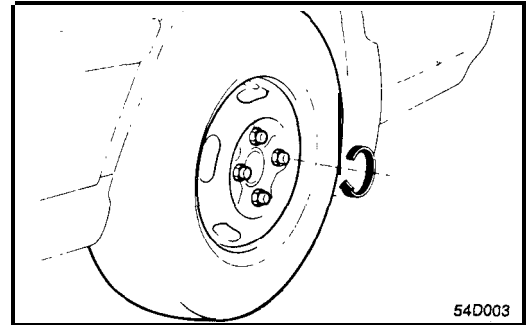

STRUT ASSEMBLY

COMPONENTS

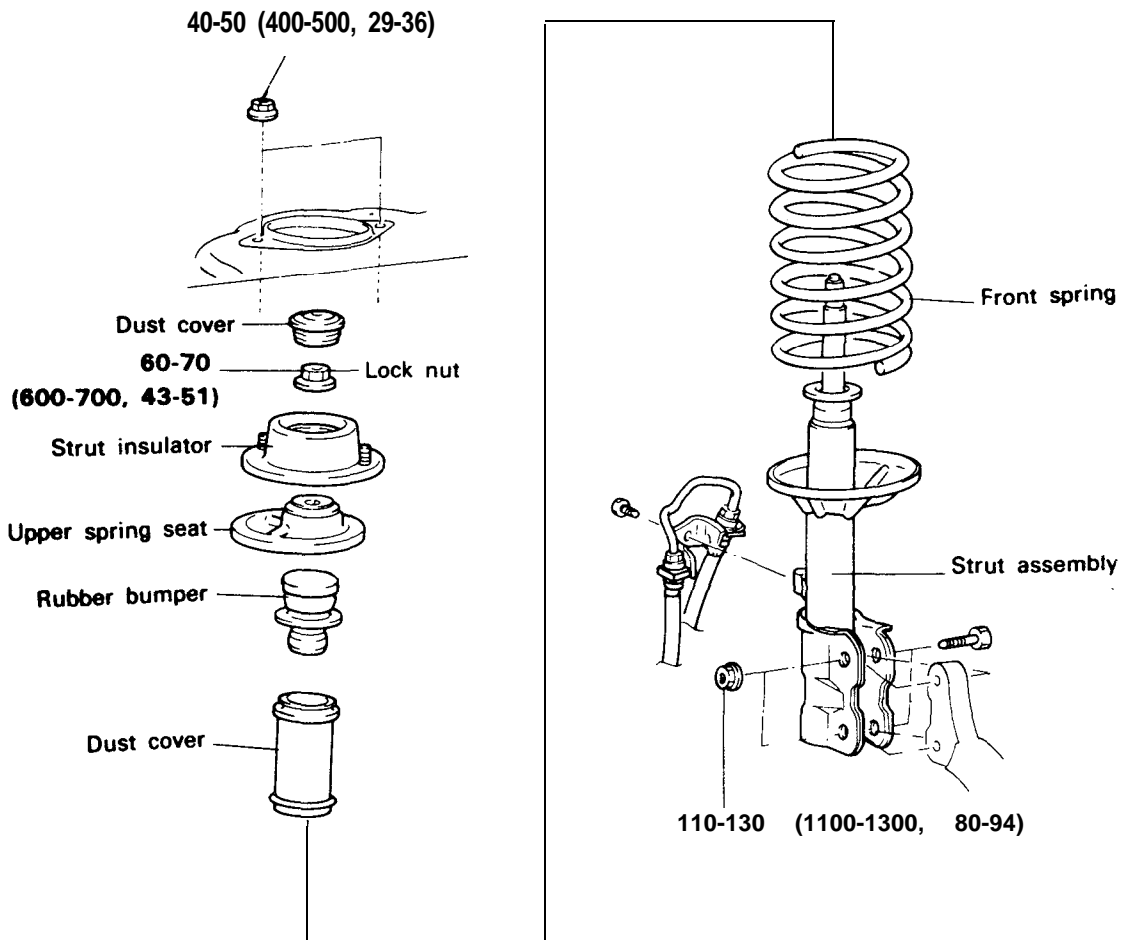

TORQUE : Nm (kg.cm, lb.ft)

REMOVAL

1. Raise the front of the vehicle and mount it on a jack stand.
2. Remove the wheel and tire.
3. Detach the brake hose and tube bracket from the strut assembly.

NOTE

Do not pry or force the components.

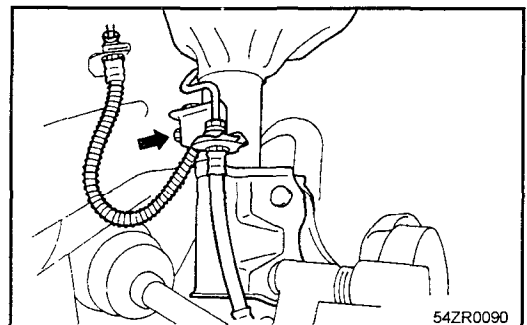

4. Remove the strut assembly from the knuckle and wheel house.

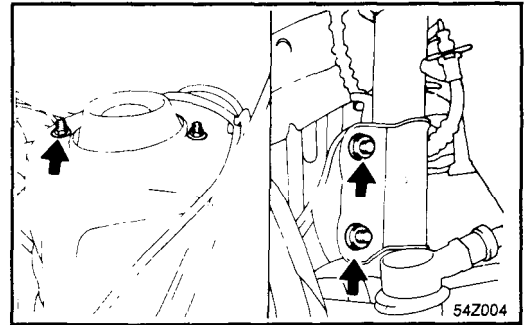

DISASSEMBLY

1. Using special tool, spring compressor, compress the coil spring.
2. Holding the upper spring seat with special tool, special spanner, loosen the nut at the top end of the shock absorber and remove the insulator.
3. Remove the spring seat, spring and rubber bumper.

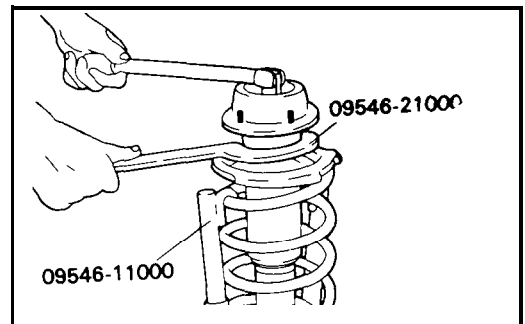
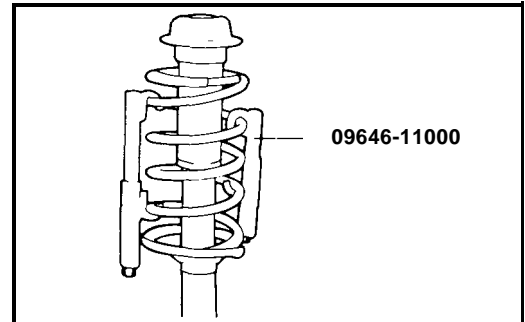

INSPECTION

1. Check the bearing for wear.
2. Check the rubber parts for cracks and wear.
3. Check the coil spring for sagging and weakness.

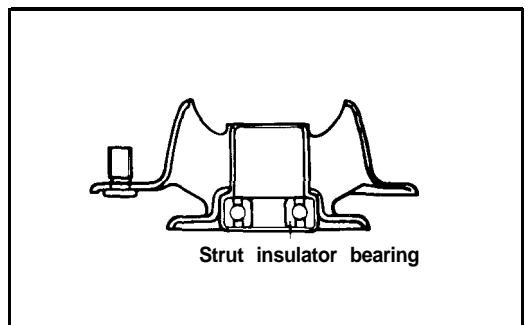

ASSEMBLY

1. Install special tool, on the coil spring and compress the spring. After spring is fully compressed, install it on the strut sub-assembly.

NOTE

Install the coil spring with the identification mark directed toward the knuckle.

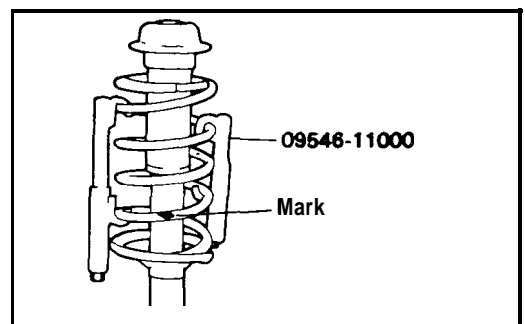

2. Install the rubber bumper, upper rubber seat, upper seat assy, insulator and washer in the order.

NOTE

Align the D-shaped hole in the spring seat upper assembly with the indentation on the piston rod.

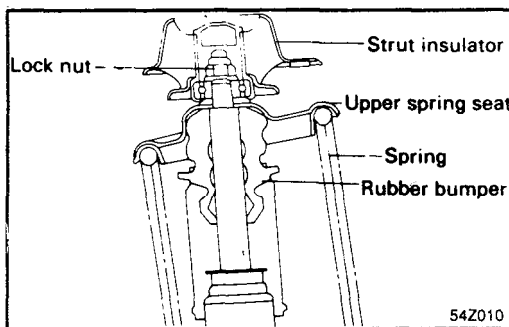

3. After having correctly seated the upper and lower ends of the coil spring in the upper and lower spring seat grooves, loosen special tool.
4. Using special tool, hold the upper spring seat and tighten the self-locking nut to the specified torque.

Tightening of spring seat to piston rod
60-70 Nm (600-700 kg.cm, 43-51 lb.ft)

5. Pack grease in the strut upper bearing and install the cap.

CAUTION

Make sure that no grease is on the insulator rubber.

Recommended grease
SAE J310a, Chassis grease (NLGI No.0, equivalent)

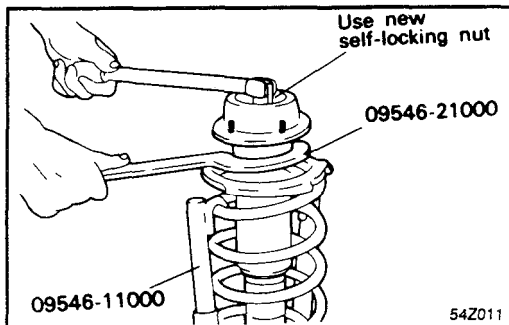

INSTALLATION

1. When installing the strut, the mating surface must be clean.
2. Tighten the following parts to the specified torque.

Tightening torque	Nm (kg.cm, lb.ft)
Strut upper installation nut	40-50 (400-500, 29-36)
Strut assembly to knuckle	11 (1100-1300, 80-94)

3. Install the brake hose and bleed the brake system.

COMPONENTS

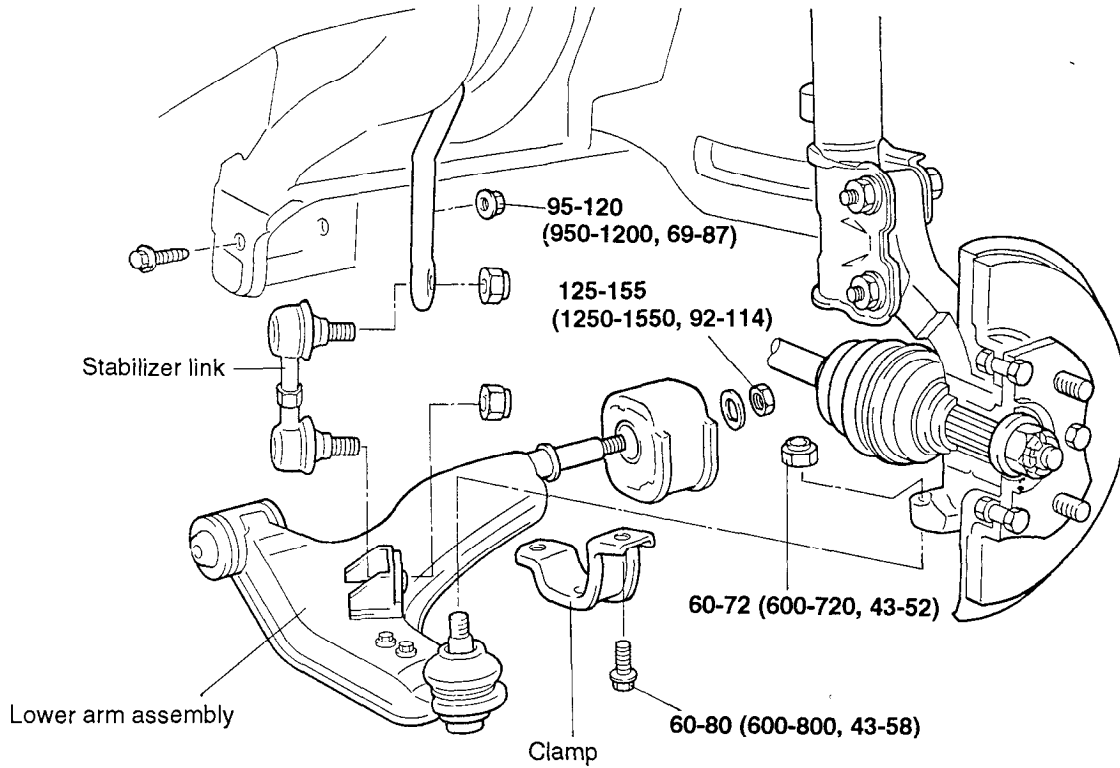

TORQUE : Nm (kg.cm, lb.ft)

REMOVAL

1. Using special tool, disconnect the lower arm ball joint from the knuckle.

NOTE

Be sure to tie a cord to the special tool and to a nearby part.

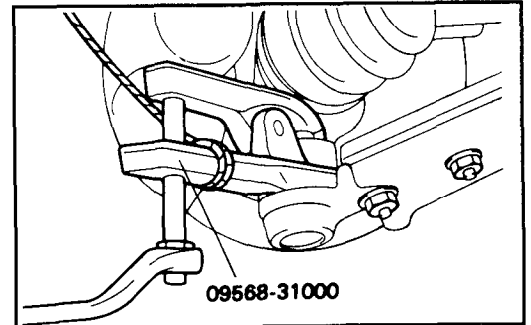

2. Remove the stabilizer link mounting self-locking nut, and detach the stabilizer bar from the lower arm.

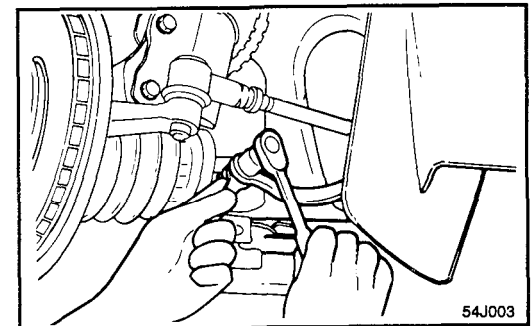

3. Remove the lower arm mounting nut and bolt.

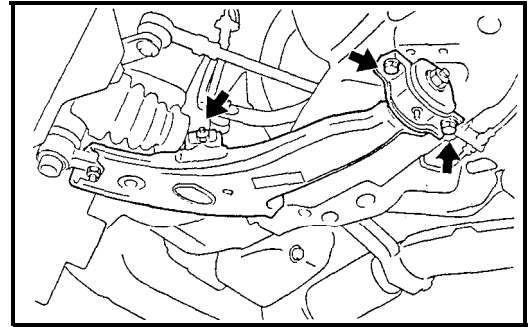

INSPECTION

1. Check the lower arm for bend or breakage.
2. Check the clamp for deterioration or damage.
3. Check the ball joint dust cover for cracks.
4. Check all bolts for condition and straightness.

INSPECTION OF BALL JOINTS

1. Remove the ball joint assembly from the lower arm.
2. Inspect the ball joints for rotation condition.
 - 1) As shown in the figure, flip the ball joint stud back and forth 5 times.
Using a torque gauge, measure rotation starting torque.

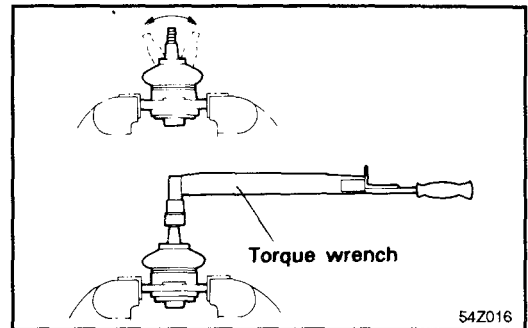

Rotation condition [Standard value]	Nm (kg.cm, lbf-in)
Vertical play	0
Rotation starting torque	2-9.5 (20-95, 17.7-84.1)
Rotating torque	2-5.5 (20-55, 17.7-48.7)

BALL JOINT AND DUST COVER REPLACEMENT

1. Remove the dust cover from the ball joint.
2. Pack the specified grease or equivalent in the new dust cover.

Recommended grease	Sunlight MB-2
--------------------------	---------------

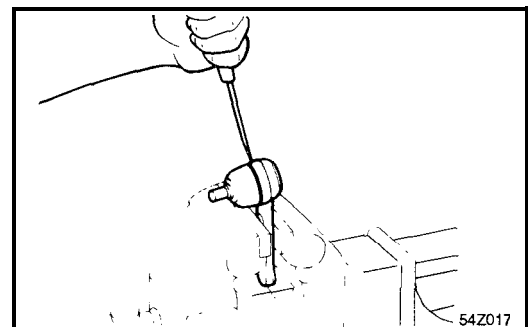

3. Press fit the dust cover to the ball joint with special tool.

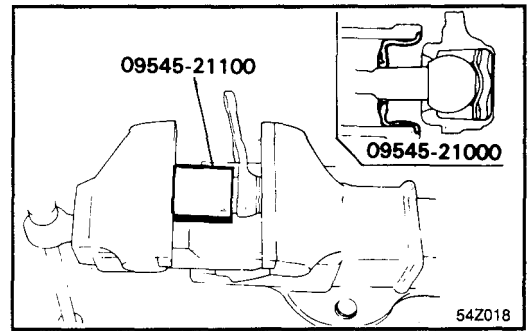

LOWER ARM BUSHING (A) REPLACEMENT

1. Install the Special Tools (09545-28000, 09545-28100) on the lower arm
2. Press out the bushing.

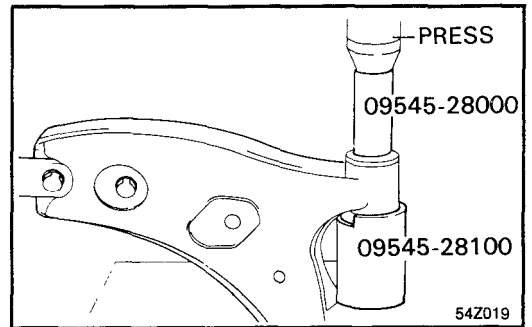

3. Apply soap solution to the following portions.
 - 1) Outer surface of the new bushing.
 - 2) Inner surface of the lower arm bushing mount.
 - 3) Inner surface of the Special Tools.

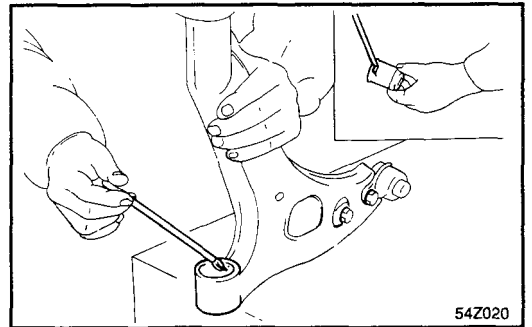

4. Install the Special Tools and new bushing onto the lower arm.
5. Press fit the bushing into the lower arm bushing mount.

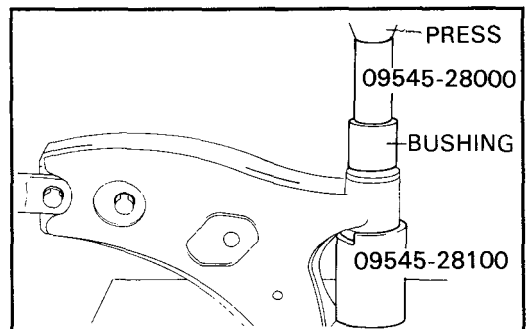

6. Center the bushing by the following procedure, if necessary.
 - 1) Reset the Special Tools and lower arm.
 - 2) Center the bushing.

NOTE

After centering the bushing, wipe off the soap solution.

LOWER ARM BUSHING (B) REPLACEMENT

1. Align the washer with the flat area provided on the lower arm mounting part.
2. After positioning the lower arm bushing (B) at the angle indicated in the illustration, install the self-locking nut.

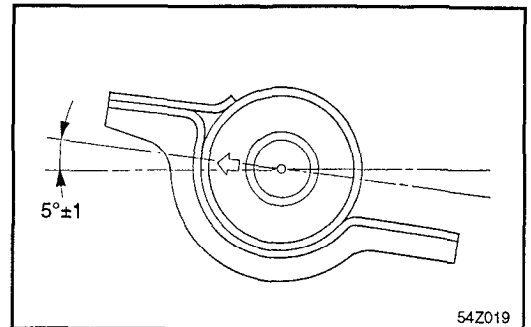
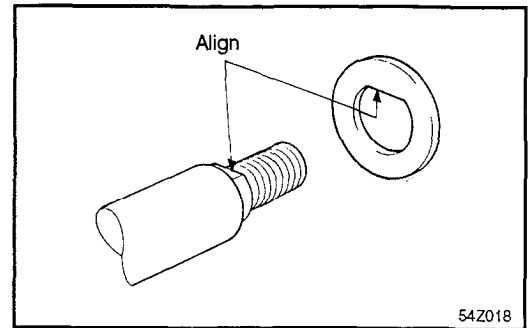

INSTALLATION

1. Install the lower arm mounting bolt and nut.

Lower arm front mounting nut	95-120 Nm (950-1200 kg.cm, 69-87 lb.ft)
Lower arm rear mounting bolt	60-80 Nm (600-800 kg.cm, 43-58 lb.ft)

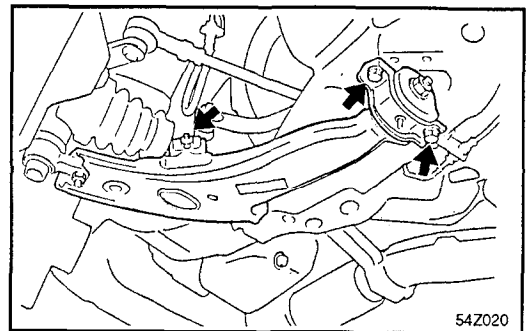

2. Tighten the stabilizer link with a spanner wrench (14 mm or 9/16 in.) then install the self locking nut.

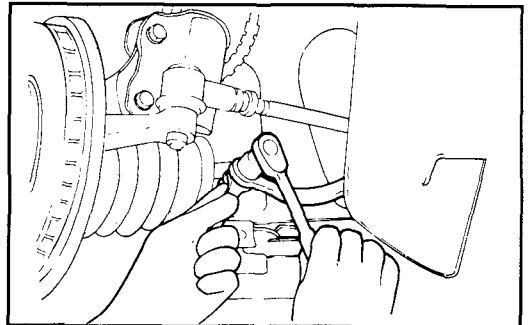

COMPONENTS

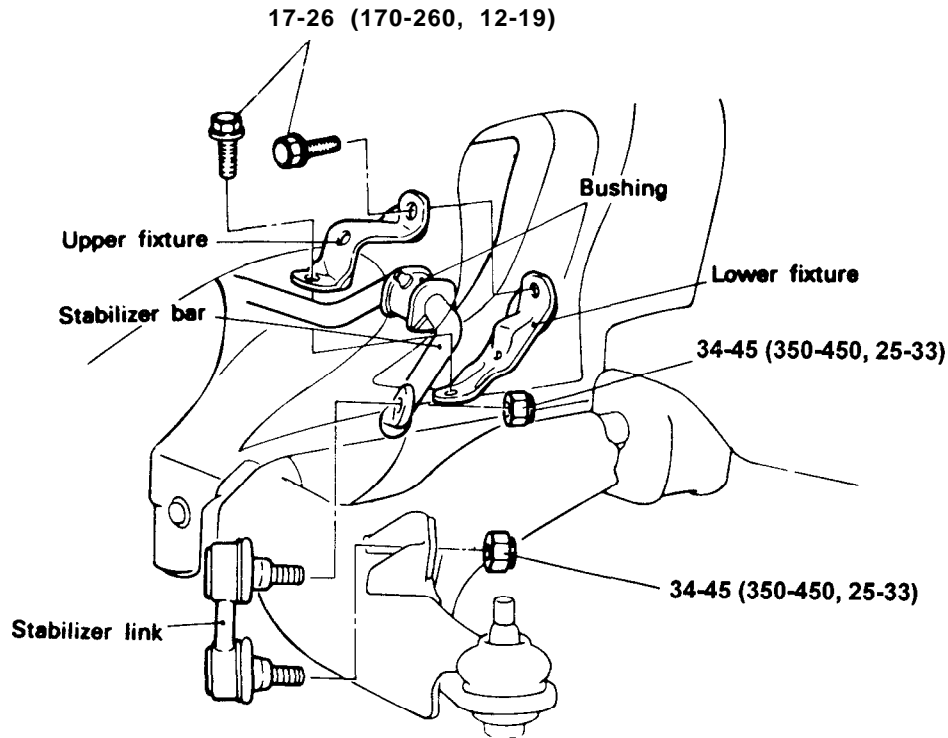

TORQUE : Nm (kg.cm, lb.ft)

REMOVAL

1. Disconnect the tie rod end ball joint from the knuckle using special tool.

NOTE

Be sure to tie a cord to the special tool and to a nearby prt.

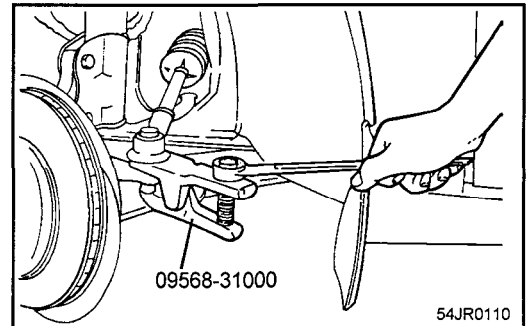

2. Remove the stabilizer link self locking nut with a spanner wrench (14 mm or 9/16 in.)

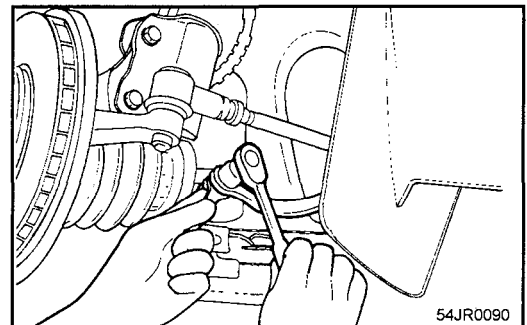

3. Remove the stabilizer bar through the access opening.
4. Detach the upper and lower fixtures; then remove the bushing.

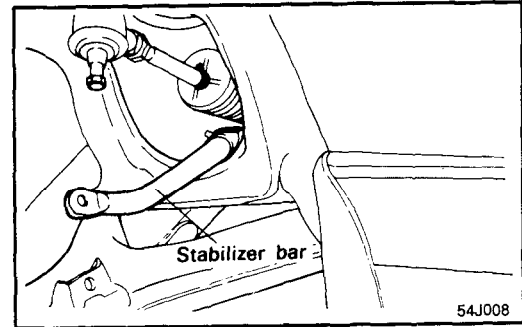

INSPECTION

1. Check the stabilizer bar for deterioration and damage.
2. Check all bolts for condition and straightness.

INSTALLATION

1. Install the bushing onto the stabilizer bar.
2. Align the upper and lower fixtures with the bushing. Make sure the projections are securely in the space between the fixtures.

NOTE

When installing, distinguish the fixtures by noting their identification mark.

Identification mark : R for R.H. side
L for L.H. side

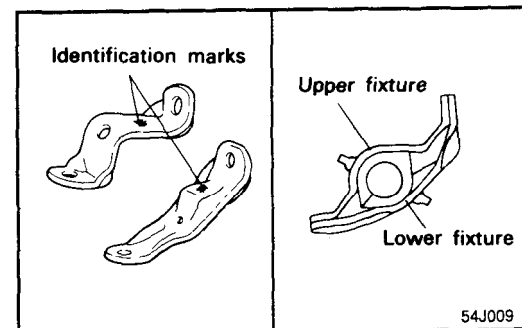

3. Using the access opening, temporarily tighten the bushing fixtures then position the opposite side bushing.

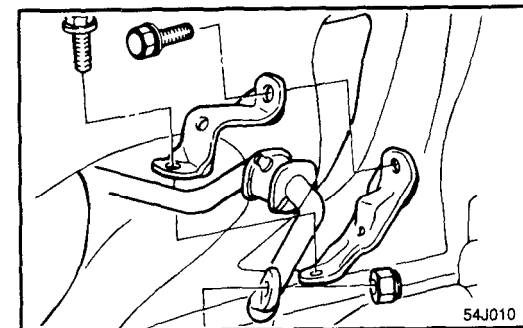

4. Tighten the stabilizer link with a spanner wrench (14 mm or 9/16 in.) then install the self locking nut.
5. Connect the tie rod end ball joint to the knuckle.

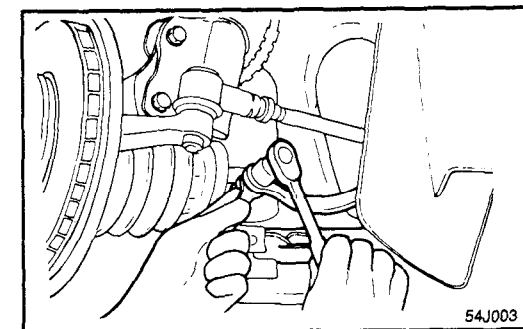

CENTER MEMBER

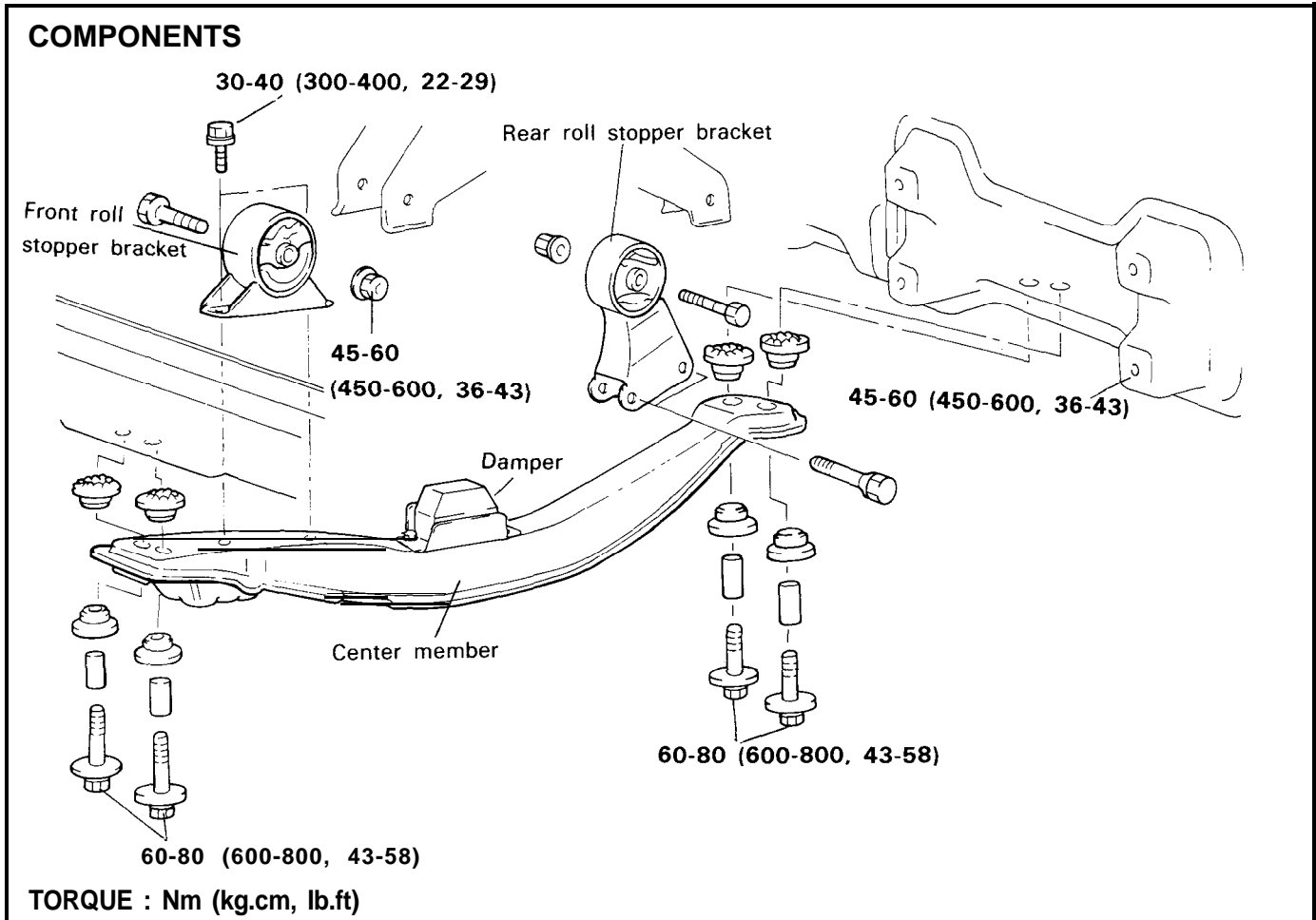

REMOVAL

1. Raise the vehicle and position the jack stands.
2. Detach the front and rear roll stopper brackets from the engine mounting bracket.
3. Remove the center member assembly.

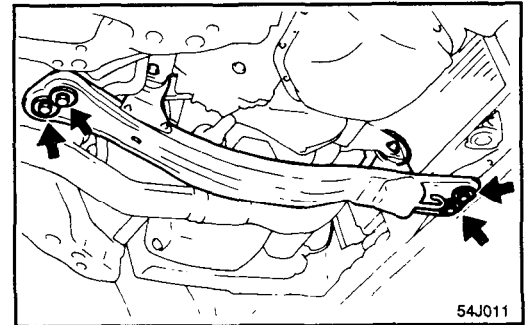

INSPECTION

1. Check each insulator and bushing for cracks or deterioration.
2. Check each bracket for distortion or damage.

INSTALLATION

1. Install the front roll stopper bracket so that its round hole faces forward.

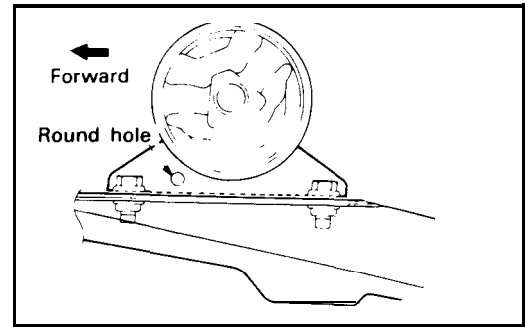

2. Fit the rear roll stopper bracket to the center member, and install the center member assembly.
3. Temporarily tighten the front roll stopper bracket bolt. After the total weight of the engine has been placed on the vehicle body, securely tighten the nut.

Center member mounting bolt	60-80 Nm (600-800 kg.cm, 43-58 lb.ft)
Front roll stopper bracket to center member bolt	30-40 Nm (300-400 kg.cm, 25-29 lb.ft)
Rear roll stopper bracket to center member bolt	45-60 Nm (450-600 kg.cm, 33-43 lb.ft)
Insulator to engine mounting bracket bolts	45-60 Nm (450-600 kg.cm, 33-43 lb.ft)

WHEEL AND TIRE

WHEEL ROTATION

1. Rotate the tires in the patterns illustrated.

NOTE

The temporary spare tire should not be used in the wheel rotation.

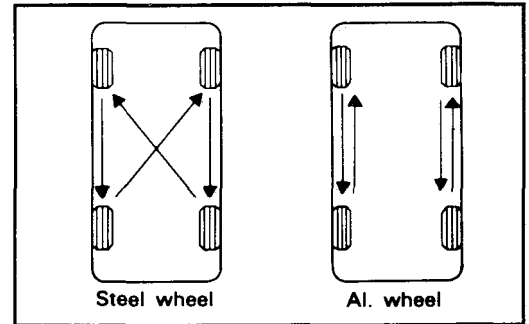

Checking for pull and wander

1. If the steering pulls to one side, use the following wheel rotation procedure.
 - 1) Switch the front right and front left tires, and perform the road test in order to confirm vehicle stability.

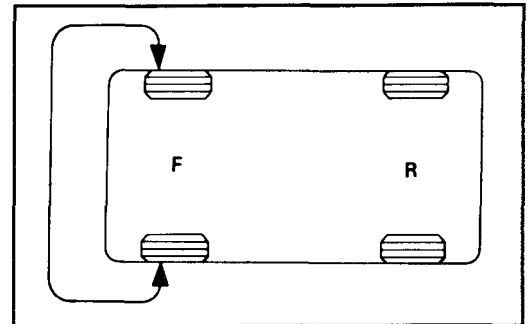

- 2) If the steering pulls to opposite side, switch the front and rear tires, and again perform the road test.

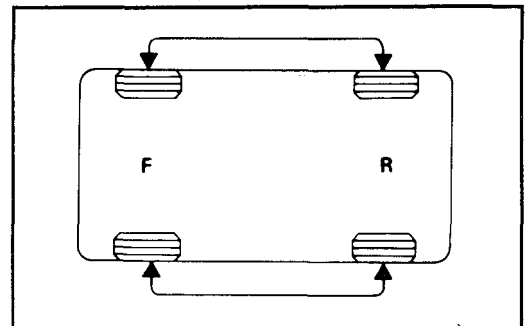

- 3) If the steering continues to pull to one side, switch the front right and left tires again, and again perform the road test.

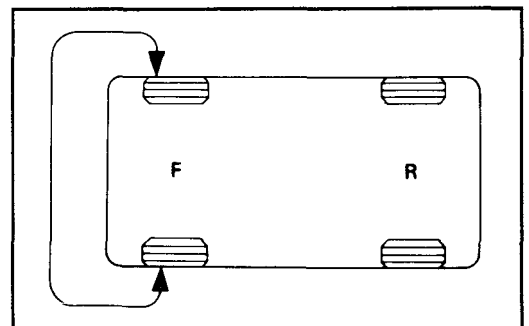

- 4) If the steering continues to pull to the opposite side, replace the front wheels with new ones.

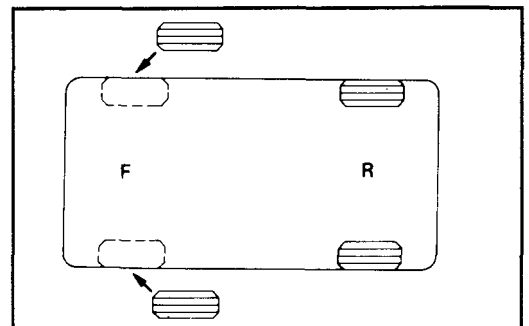

INSTRUCTIONS FOR ALUMINUM TYPE WHEELS

1. Aluminum is vulnerable to alkalies. If the vehicle has been exposed to automobile washing detergent, or salt from sea water, or road chemicals, rinse the vehicle as soon as possible. Then apply wax to the wheels to prevent corrosion.
2. When steam cleaning the vehicle, do not direct the steam onto the aluminum wheels.
When tightening nuts for aluminum wheels, observe the following:
 - 1) Clean the hub surface.
 - 2) After finger-tightening the wheel nuts, tighten to specifications.
 - 3) Do not use an impact wrench or push the wrench by foot to tighten the wheel nuts.
 - 4) Do not apply oil to the threaded portions.

TIRE CHAINS AND SNOW TIRES

1. Use tire chains only on the front wheels. Do not use tire chains on rear wheels.
2. When using snow tires, use them on all four wheels for maneuverability and safety.